

PROJECT	QUANTITY	ITEM NO
---------	----------	---------

# FlexFusion™ Combi Oven

## Space\$aver™ Plus



**FSEN610** Electric

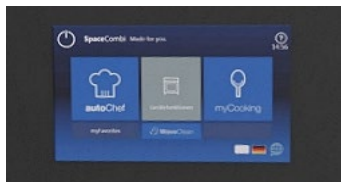

Chef'sTouch control: Just tap and swipe to run automated cooking and operating apps

Henny Penny FlexFusion combi ovens combine different cooking methods into one piece of equipment with the flexibility to cook nearly everything on your menu to perfection.

The FlexFusion Space\$aver Plus combi incorporates powerful yet highly energy-efficient boilerless steam generation into a compact tabletop unit less than 22 inches wide with racking for full-size steam table pans. Perfect for smaller operations with limited kitchen space. This system instantly adds or eliminates the precise amount of moisture needed to maintain desired cooking conditions.

What really sets FlexFusion apart is its ease of use. The Space\$aver Plus features an updated version of Chef'sTouch, an intuitive control system with a durable 7-inch touch/swipe screen that makes cooking with FlexFusion as easy as

using a smart phone! Just tap the app for everything from cook-and-hold to cleaning and trouble-shooting.

FlexFusion FSEN610 earns the ENERGY STAR® mark for energy efficiency. WaveClean™ self-cleaning system, multi-sensor core temperature probe and USB port are standard.

Removable tilt-resistant rails accept full-size steam table pans or half-size sheet pans and grids.

#### Popular FlexFusion built-in Apps:

- **AutoChef**—Tap/swipe to select cooking programs and features
- **ChefsHelp**—Intuitive training and instruction with graphics and video
- **FamilyMix**—Shows which items can be cooked together
- **GreenInside**—Displays energy and water use for each cooking program
- **CombiDoctor**—Runs system self-diagnostics and displays results

### Standard Features

- Chef'sTouch™ Control System for Automatic or easy manual cooking
  - Durable 7-inch high resolution touch/swipe screen
  - Full-color display, video assist
  - Select from up to 350 cooking programs in AutoChef memory
  - Create and store custom cooking programs of up to 20 steps each
  - Select and use apps for cooking, serving convenience, cleaning, diagnostics and more
  - Use ClimaSelect Plus to set and maintain humidity levels at 10% increments from 0% to 100% RH
  - Adjust individual settings before or during cooking
  - Multi-sensor food probe
  - Temperature in °F or °C
  - Choose language for operations and service diagnostics
- Accepts full-size steam table pans on 5 or 6-levels
- Removable tilt-resistant wire pan rack for optimal air flow and sanitation
- DynaSteam2 precision boilerless steam generation
- Improved 5-speed auto-reverse fanwheel for fast, even cooking throughout the cabinet
- Powerful high-efficiency motor uses up to 15% less energy
- Full perimeter door seal
- Triple-pane glass saves 28% more energy over ventilated door system
- Integrated LED lighting in window perimeter for improved viewing
- Earns the ENERGY STAR® mark for energy efficiency
- Improved WaveClean® self-cleaning system uses 36% less water
- Stainless steel interior cabinet with coved corners
- 1 mm stainless steel exterior
- Easy access for maintenance and repair
- USB port for convenient download of programs, diagnostic messages or HACCP data
- Available as FSHN610 with integrated hood\*

#### Options, accessories\*

- Two-in-one cleaning cartridges
  - Stands and wall bracket
  - Stacking kit
  - Barcode scanner
  - Left-hinged door
- Choose wire pan rack:
- 5 levels
  - 6 levels

\*See separate data sheets for details

<input type="checkbox"/> APPROVED	<input type="checkbox"/> APPROVED AS NOTED	<input type="checkbox"/> RESUBMIT
AUTHORIZED SIGNATURE		DATE



PROJECT

ITEM NO

# FlexFusion™ Combi Oven

## SpaceSaver™ Plus

FSEN610 Electric

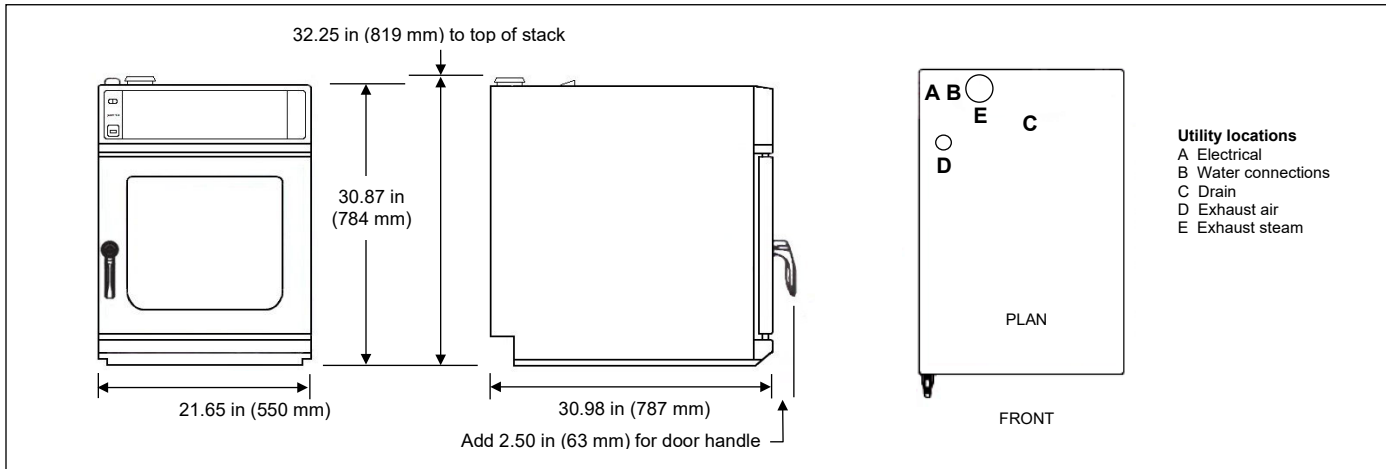

### Dimensions

Height	30.87 in (784 mm)
	32.25 in (819 mm) top of stack
Width	21.65 in (550 mm)
Depth	30.98 in (787 mm)

### Crated

Length	36 in (920 mm)
Depth	25 in (620 mm)
Height	34 in (860 mm)
Volume	18 ft <sup>3</sup> (0.5 m <sup>3</sup> )
Weight	176 lb (80 kg)

### Required clearances

Sides	2 in (50 mm) air flow
Back	2 in (50 mm) air flow, utilities
Front	28 in (700 mm) door open

### Heat (see also Cooking mode profiles)

Max temperature 572°F (300°C)

### Water

0.75 in standard cold water connection  
 0.75 in soft water connection  
 1.5 in (40 mm) drain

### Capacity

- 5 full-size 2.5 in (65 mm) steam table pans  
OR
- 6 half-size sheet pans 13 x 18 x 1 in  
(330 x 457 x 25 mm)

### Cooking mode profiles

Steaming/moist heat  
 86-266°F (30-130°C)  
 Low and high temperature steaming

Convection cooking/dry heat  
 86-572°F (30-300°C) electric  
 Active humidity reduction

Combination/dry + moist heat  
 86-482°F (30-250°C)  
 Manual or automatic humidity control  
 between 0 and 100% RH

Rethermalizing/dry + moist heat  
 86-356°F (30-180°C)  
 Special fan 5-speed function, banqueting programs

### Bidding specifications

Provide Henny Penny FlexFusion SpaceSaver™ Plus model FSEN610 electric combi oven, designed to cook with steaming/moist heat, convection/dry heat, or a combination of dry and moist heat, and holding up to 5 full-size steam table pans 2.5 in (65 mm) or 6 half-size sheet pans 1 in (25 mm) pans or grids on removable tilt-resistant wire pan rack.

### Unit shall incorporate:

- Chef's Touch Control System featuring protected full-color capacitive touch screen with automatic and manual cooking capability, ClimaSelect Plus humidity control and designated pre-loaded apps
- Boilerless DynaSteam2 Technology with precise humidity generation
- Variable speed, auto reverse fanwheel that moves air in alternating directions for more even heating
- Unit earns the ENERGY STAR® mark
- Automated WaveClean® self-cleaning system
- Seamless stainless steel cooking chamber, full-perimeter door seal and triple-pane glass for energy efficiency
- Cabinet exterior 20-gauge stainless steel

### Electrical

Volts	Phase	Hertz	kW	Amps	Wire*
208	3	60	7.4	22.2	3+G

### Laboratory certifications



\*Units shipped with power cord

Continuing product improvement may subject specifications to change without notice.

### 24 Hour Technical Support:

Henny Penny Technical Service  
 800 417.8405  
[technicalservices@hennypenny.com](mailto:technicalservices@hennypenny.com)

Henny Penny Corporation  
 PO Box 60 Eaton OH 45320 USA  
 +1 937 456.8400 800 417.8417  
 +1 937 456.8434 Fax 800 417.8434 Fax  
[www.hennypenny.com](http://www.hennypenny.com)

**HENNY PENNY**  
 Engineered to Last