

A 1000 FLEX

You no longer need to choose! The A 1000 Flex combines the best of both worlds with espresso-based beverages and freshly-brewed coffee in one machine. With integrated features such as the FoamMaster™ milk system for perfectly foamed or steamed milk and our patented iQFlow™ technology that delivers superior coffee extraction, creating the perfect beverage is at your fingertips. The optional Flavor Station allows you to select from up to 6 different flavors to customize your drink. The 10.4-inch intuitive and configurable touch screen with video and audio capabilities, makes the A 1000 Flex a state-of-the-art coffee machine that can always be relied on. The A 1000 Flex is easy to maintain with the CleanMaster™ automatic milk cleaning system. Simply follow the prompts on the display to activate the cleaning process.

RECOMMENDED DAILY OUTPUT

Cups per Day: Up to 300



iQFlow™

the groundbreaking technology that extracts more flavor for unrivaled in-cup-quality



TOUCH SCREEN

10.4-inch display with incredibly simple operating concept and attractive product presentation



FOAMMASTER™

module integrated as standard for perfect foam, every time



CLEANMASTER™

Fully automatic cleaning process meeting highest hygiene standards

FRANKE

MAKE IT WONDERFUL

YOUR A 1000 FLEX: CONFIGURED TO YOUR PREFERENCES

1 A 1000 FLEX FEATURES

- One pre-set espresso bean hopper & grinder: 2.6 lbs., lockable (position: rear left)
- One pre-set coffee bean hopper (House Blend) & grinder: 2.6 lbs., lockable (position: rear right)
- One pre-set coffee bean hopper (Single-Origin) & grinder: 1.3 lbs., lockable (position: front left)
- One chocolate powder dosing system: 1.3 lbs., lockable (position: front right)
- Cup sensor
- iQFlow™
- Automatic height-adjusting dispensing outlet

Optional Features:

- Coffee grounds chute

Special Order:

- Autosteam Pro (S3) steam wand (automatic milk foaming)

2 MILK AND CLEANING SYSTEM

- FoamMaster™ (FM): hot and cold milk and milk foam, individually adjustable consistency, integrated cleaning system
- CleanMaster (CM): fully automatic cleaning system with integrated cleaning cartridge and integrated cleaning tank. For outstanding hygiene and unbeatable simplicity, efficiency, and convenience.

Milk Capacity:

- 2 x 1 gallon, 2 x 4 liter container or 1 x 10 liter container

3 FLAVOR STATION

- Automatic dosing station for up to six flavors.

4 ACCOUNTING SYSTEM

- Can be used for various payment methods, Mastercard or Visa cards, Apple Pay and NFC (near field communication) payment methods

5 CUP WARMER

- With four heatable trays.



Black/chrome

FLEXIBILITY

Our product portfolio allows various assembly options – tailored to your needs.



MAKE IT WONDERFUL

Franke Kaffeemaschinen AG
cs-info.ch@franke.com

Franke Coffee Systems GmbH
cs-info.de@franke.com

Franke Coffee Systems Americas
cs-customerservice.us@franke.com

Franke Coffee Systems UK
sales@Frankecoffeeysystems.co.uk

800.310.5710
coffee.franke.com

TECHNICAL DATA

MACHINE MODEL

1 A1000 Flex FM CM	
Electrical Connection	200-220V (30 A)
Dimensions	13.4 in/ 33.5 in/ 23.6 in (W/H/D)
Weight (empty)	220 lbs (FM CM incl. SU12 CM)

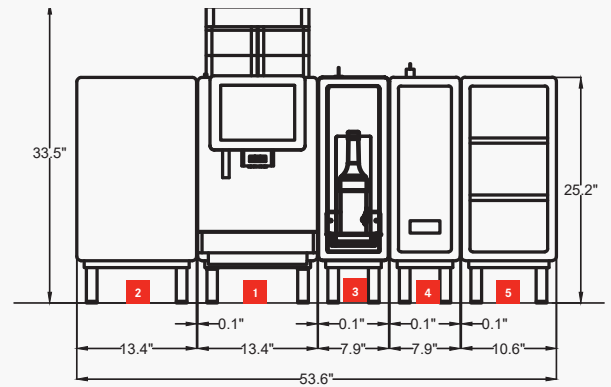

L6-30R



WATER QUALITY REQUIREMENTS

Aroma	Fresh and pure taste, with no perceptible aroma
Color	Clear
Total Hardness	70 – 140 ppm (mg/l)
	4-8 gpg
Carbonate hardness	3 - 6° dH CH (carbonate hardness)
	50 – 105 ppm (mg/l)
Acid content/ph value	6.5 – 7.5 pH
Chlorine content	< 0.5 mg/l
Chloride content	< 30 mg/l
TDS	30 – 150 ppm (mg/l)
(Total dissolved solids)	
Electrical conductivity	50 – 200 μ S/cm (microsiemens)
Iron Content	< 0.3 mg/l
Water pressure	80 – 800 kPa (0.8 – 8 bar)
Flow rate	> 0.1 l/sec
Water temperature	< 25°C

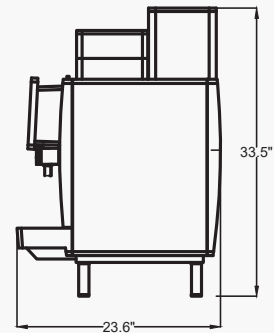

WATER CONNECTION AND DRAIN

Water connection	3/8" compression fitting, L = 59 in
Drain hose	2x Dia = 0.75 in, L = 78.7 In

ADD-ON UNITS

2 REFRIGERATION UNIT

Electrical connection	SU12 CM (12 I) 120V (15 A)
Dimensions	13.4 in / 25.3 in / 18.7in (W/H/D)
Weight (empty)	approx. 57 lbs
Colors	Black

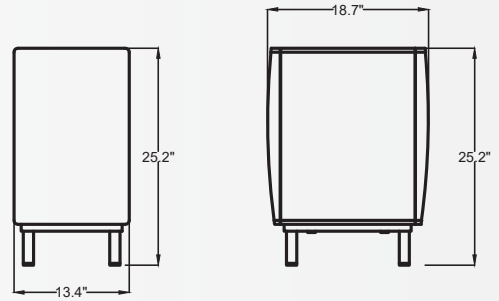

3 FLAVOR STATION

Electrical connection	FS6 120V (10 A)
Dimensions	7.9" / 25.2 in / 17.8 in (W/H/D)
Weight (empty)	approx. 48 lbs
Colors	Black

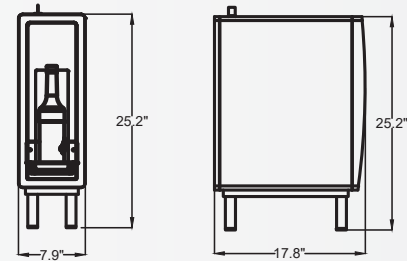

4 ACCOUNTING SYSTEM

Accounting systems	AC 200 Cashless payment system
Electrical connection	120V (10 A)
Dimensions	7.9 in / 25.2 in / 17.8 in
Weight (empty)	approx. 40 lbs
Colors	Black

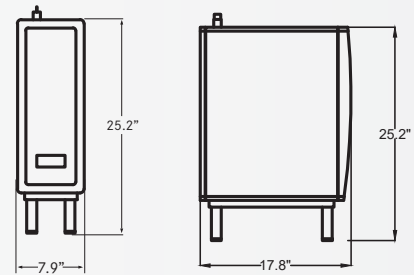

ACCOUNTING SYSTEM

Accounting systems	AC125CL Cashless payment system
Electrical connection	120V (10 A)
Dimensions	5 in x 6 in x 12 in
Weight (empty)	4 lbs
Colors	Black



ADD-ON UNITS

5 CUP WARMER

Electrical connection

Dimensions

Weight (empty)

Compatible with

Colors

CW

120V (15 A)

10.6 in x 25.2 in x 17.9 in

44 lbs

A1000 FM CM

Black

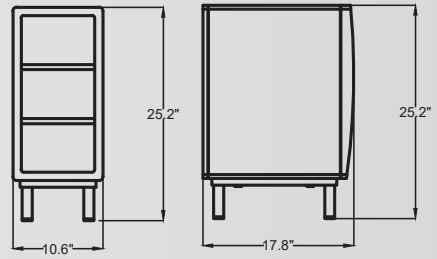

5-15R



Intertek

3123505

ETL LISTED CONFORMS TO
UL STD 197 CERTIFIED TO
CSA STD C22.2
NO 109



Intertek

CONFORMS TO
NSF STD 4