

PROJECT	QUANTITY	ITEM NO
---------	----------	---------

Large Capacity Open Fryers

OFE 341 1-well electric
OFE 342 2-well electric



OFE 342 2-well large capacity electric open fryer with Computron™ 8000 control

Henny Penny open fryers offer high-volume frying with programmable operation, oil management functions and fast, easy filtration.

The 340 series large capacity open fryers offer maximum frying surface area within an economical footprint. A larger, shallower fry vat produces more consistent frying results with items that float when cooking.

Henny Penny electric open fryers combine power and efficient heating to recover temperature very quickly. Fast recovery translates into higher throughput, lower energy costs and longer frying oil life.

Henny Penny open fryers have a built-in filtration system that filters and returns hot frying oil in minutes. No separate pumps and pans, no handling hot oil. Frequent filtering

extends frying oil life, improves product quality and reduces oil costs.

The Computron™ 8000 control features automatic, programmable operation, as well as energy-saving, filtration and cook management functions.

The Computron™ 1000 control offers programmability in a simple, easy to use digital control panel with LED display.

Standard Features

- Heavy-duty stainless steel vats with 7-year warranty
- Larger, shallow vat offers large surface area that promotes more even cooking
- Specially designed “beach” accommodates oil displacement when lowering basket
- High-efficiency heating elements generate fast recovery and energy savings
- Cold zone below heating elements helps extend oil life
- High-limit temperature protection
- Built-in filtration with over-the-top oil return to flush remnants
- Easy basket set and release
- Stainless steel construction for easy-cleaning and long life
- 4 heavy-duty casters, 2 locking
- Computron™ 8000 control (additional charge)
 - 12 programmable cook cycles
 - Melt mode
 - Idle mode
 - Clean-out mode
 - Load compensation
 - Proportional control
 - Optional filter prompt and customizable filter tracking
 - 16-character digital display with multiple language settings
- Computron™ 1000 control
 - Programmable
 - LED Time/Temp display
 - Simple UP/DOWN arrows

Accessories shipped with unit

- Fry baskets—please select one
 - 1 full basket per well
 - 2 half baskets per well
- 1 basket support for each vat
- Lift tool for basket support
- Lift tool for heating elements
- Filter screen and filter envelope

Options available separately

- 3 third-size baskets per well
- Fryer Shortening Shuttle®
- Choose one:
 - Filter rinse hose OR
 - Direct Connect shortening disposal

<input type="checkbox"/> APPROVED	<input type="checkbox"/> APPROVED AS NOTED	<input type="checkbox"/> RESUBMIT
AUTHORIZED SIGNATURE		DATE



PROJECT

ITEM NO

Large Capacity Open Fryers

OFE 341 1-well electric
OFE 342 2-well electric

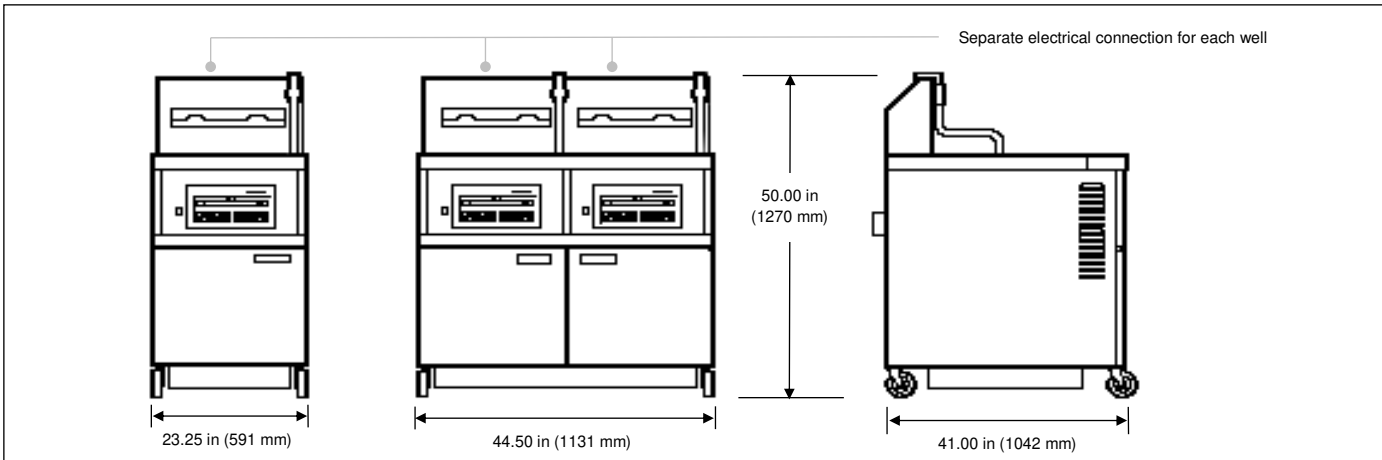

	OFE 341	OFE 342
--	---------	---------

Dimensions

Width	23.25 in (591 mm)	44.50 in (1131 mm)
Depth	41.00 in (1042 mm)	41.00 in (1042 mm)
Height	50.00 in (1270 mm)	50.00 in (1270 mm)

Crated

Length	46 in (1169 mm)	51 in (1296 mm)
Depth	30 in (762 mm)	46 in (1169 mm)
Height	66 in (1676 mm)	66 in (1676 mm)
Volume	53 ft ³ (1.5 m ³)	90 ft ³ (2.5 m ³)
Weight	348 lb (158 kg)	554 lb (251 kg)

Heating immersed elements

Output	22.0 kW total	44.0 kW total
--------	---------------	---------------

Oil capacity

80 lb or 38 L per vat

Required clearances

Sides	N/A
Back	N/A
Front	30 in (762 mm) remove filter pan

Bidding Specifications

Provide Henny Penny model OFE 341 or 342 large capacity electric open fryer, 80 lb or 38 L oil capacity per vat, and built-in filtration system.

Unit shall incorporate:

- Computron™ 1000 simple digital control OR Computron™ 8000 control system (additional charge) with programmable or manual operation, LED digital display, idle and melt modes, load compensation, filtration tracking and 7-day history
- Fry vats of heavy duty stainless steel with 7-year warranty
- Shallow vat design with larger surface area and beach to compensate for load displacement
- 4 heavy-duty casters, 2 locking

Electrical

Volts	Phase	Hertz	kW per well	Amps per well	Wire*	Cord & Plug Not available for all destinations
208	3	60	22.0	62.0	3+G	Please contact Henny Penny
240	3	60	22.0	53.0	3+G	
380-415	3	50	22.0	32.5	3NG	
480	3	60	22.0	27.0	3+G	

Laboratory certifications



*Separate electrical connection required for each well. Units shipped without power cord and plug must have power cord and plug installed on site by a qualified electrician.

Continuing product improvement may subject specifications to change without notice.

24 Hour Technical Support:
 Henny Penny Technical Service
 800 417.8405
technicalservices@hennypenny.com

Henny Penny Corporation
 PO Box 60 Eaton OH 45320 USA
 +1 937 456.8400 800 417.8417
 +1 937 456.8434 Fax 800 417.8434 Fax
www.hennypenny.com

HENNY PENNY
 Engineered to Last