

SERVICE MANUAL



Model C602 Combination Shake/ Soft Serve Freezer

Original Service Instructions

057888-S

**1/07 (Original Publication)
(Updated 7/14/2023)**

CAUTION: Information in this manual is intended to be used by Taylor service technicians only.

Note: *Continuing research results in steady improvements; therefore, information in this manual is subject to change without notice.*

Note: *Only instructions originating from the factory or its authorized translation representative(s) are considered to be the original set of instructions.*

© January 2007 Taylor Company

(Updated 7/14/2023)

057888-S

Any unauthorized reproduction, disclosure, or distribution of copies by any person of any portion of this work may be a violation of Copyright Law of the United States of America and other countries, could result in the awarding of Statutory Damages of up to \$250,000 (17 USC 504) for infringement, and may result in further civil and criminal penalties.

All rights reserved.



Taylor Company
750 N. Blackhawk Blvd.
Rockton, IL 61072

Section 1: Introduction

Safety	1-2
Model C602 Specifications	1-4
General Installation Instructions	1-6
Environmental Notices	1-11

Section 2: Controls

Running Specifications	2-2
Remote Monitoring Commissioning	2-3
Refrigeration System Schematic.	2-5
Control Panel Functions	2-6
Freezer Lockout	2-10
Service Menu	2-13
Heat Treatment	2-39
Timers	2-41
Glycol	2-43
Setting Viscosity	2-46
Portion Control (Shake).	2-47
Adjustable Draw Handle	2-48
Universal Control Overview.	2-49
Universal Control.	2-53
LONWorks® Gateway.	2-63
Electrical System.	2-64
Shake Draw.	2-67
Draw Solenoid (059462-CP).	2-71
Shake Dispensing Alignment Procedure.	2-73
Syrup.	2-77

Section 3: Troubleshooting

General Troubleshooting Guide	3-2
Air Mix Pump System Troubleshooting	3-6
Peristaltic Syrup System Troubleshooting Guide	3-7
Shake Dispensing Mechanism Troubleshooting	3-9
Shake Portion Control Troubleshooting	3-11
Pyroelectric Sensor Troubleshooting	3-12
Bacteria Troubleshooting	3-14

Section 4: Parts

Parts Warranty Explanation	4-2
Main Exploded View	4-3
Operator Parts Identification	4-6
Front View	4-8

Table of Contents

Beater Door Assembly—Shake Side	4-10
Beater Door Assembly—Soft Serve Side	4-12
Pump A.—Mix Simplified Shake - X57028-XX	4-13
Pump A.—Mix Simplified Soft Serve - X57029-XX	4-14
Brush Identification	4-15
Syrup Cabinet View	4-16
Syrup Pump and Tubes	4-17
X56652 Line A.—Syrup Door - Thick Shake Syrup	4-18
X59304 Line A.—Syrup Door - Thin Viscosity Syrup	4-19
X58450 Line A.—Syrup (Syrup-In-Bag Option)	4-20
Channel-Control	4-21
*Control Assembly—X55966-33	4-23
DEC Plate Assembly	4-25
Torque Coupling Assembly—X54722	4-26
Blower A. X53725-	4-27
Glycol Heater Assembly—X55965-27	4-28
Sensor Holder Assembly (X69102)	4-29
Heater A.—Syrup	4-30
Accessories	4-31
Syrup Pump X53800—BRN/TAN	4-33

Section 5: Parts List

Section 6: Wiring Diagrams

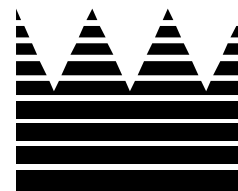

Section 1: Introduction

- **Safety**
- **Model C602 Specifications**
- **General Installation Instructions**
- **Environmental Notices**

Safety

We at Taylor are committed to manufacturing safe operating and serviceable machines. The many built-in safety features that are part of all Taylor machines are aimed at protecting operators and trained service technicians alike.

1



NOTICE! This manual is intended exclusively for Taylor service personnel.



IMPORTANT! *This machine is to be used only by trained personnel. It is not intended for use, cleaning, or maintenance by children or people with reduced physical, sensory, or mental capabilities, or lack of experience and knowledge, unless given supervision or instruction concerning the use of the machine by a person responsible for their safety. Children should be supervised to ensure that they do not play with the machine.*



CAUTION! DO NOT attempt to run the machine unless you have been properly trained to do so. Failure to do so can result in personal injury or machine damage.



WARNING! This machine must be properly grounded! **DO NOT** operate unless it is properly grounded and all service panels and access doors are fastened with screws. Failure to do so can result in severe personal injury from electrical shock!



IMPORTANT! *An equipotential grounding lug is provided with this machine. Some countries require the grounding lug to be properly attached to the rear of the frame by the authorized installer. The installation location is marked by the equipotential bonding symbol (5021 of IEC 60417-1) on both the removable panel and the machine's frame.*



WARNING! Avoid injury.

- **DO NOT** attempt any repairs unless the main power supply to the machine has been disconnected.
- **DO NOT** operate the machine with larger fuses than specified on the data label.
- Stationary machines which are not equipped with a power cord and plug or other device to disconnect the machine from the power source must have an all-pole disconnecting device with a contact gap of at least 0.125 in. (3 mm) installed in the external installation.
- Machines that are permanently connected to fixed wiring and for which leakage currents may exceed 10 mA, particularly when disconnected, not used for long periods, or during initial installation, shall have protective devices to protect against the leakage of current, such as a GFI, and be installed by authorized personnel to the local codes.
- Supply cords used with this machine shall be oil-resistant, sheathed flexible cable, not lighter than ordinary polychloroprene or other equivalent synthetic elastomer-sheathed cord (code designation 60245 IEC 57) installed with the proper cord anchorage to relieve conductors from strain, including twisting, at the terminals and protect the insulation of the conductors from abrasion.
- **For Cord-Connected Machines:** Only Taylor service technicians may install a plug on this machine.

Failure to follow these instructions may result in electrocution or damage to the machine.



WARNING! DO NOT remove any parts unless all power switches are in the OFF position. Failure to follow this instruction may result in severe personal injury from hazardous moving parts.



WARNING! This machine has many sharp edges that can cause severe injuries.

- **DO NOT** put objects or fingers in the door spout. This may contaminate the product and cause severe personal injury from blade contact.
- **USE EXTREME CAUTION** when removing the beater assembly. The scraper blades are very sharp.
- **USE EXTREME CAUTION** when handling the cup/cone dispenser (if supplied with machine). Two people are required to handle the cup/cone dispenser. The appropriate type of protective gloves must be worn and the mounting holes must **NOT** be used to lift or hold the dispenser.

Failure to follow these instructions can result in personal injury or damage to the machine.



WARNING! DO NOT attempt to draw product or disassemble the machine during the heat treatment cycle (if equipped). The product is hot and under extreme pressure. Severe burns from hot product may result if this instruction is not followed.



CAUTION! This machine must be placed on a level surface. Extreme care should be taken when moving for any reason. Two or more persons are required to safely move this machine. Failure to comply may result in personal injury or damage to the machine.



WARNING! Only install this machine in a location where its use and maintenance is restricted to trained personnel. Failure to comply may result in personal injury.



WARNING! This machine must **NOT** be installed in an area where a water jet or hose can be used. **NEVER** use a water jet or hose to rinse or clean the machine. Failure to follow this instruction may result in electrocution.



NOTICE! Cleaning and sanitizing schedules are governed by your federal, state or local regulatory agencies and must be followed accordingly. Please see the cleaning section of the Operator's Manual for the proper procedure to clean this machine.

Authorized service personnel must ensure that the proper personal protective equipment (PPE) is available and worn when required during installation and service.

Noise Level: Airborne noise emission does not exceed 78 dB(A) when measured at a distance of 39 in. (1.0 m) from the surface of the machine and at a height of 63 in. (1.6 m) from the floor.

Model C602 Specifications

Freezing Cylinders

Shake side: One 7 qt. (6.6 L) capacity.

Soft serve: One 3.4 qt. (3.2 L) capacity.

1

Mix Hopper

Two 20 qt. (18.9 L). Refrigerated to maintain mix below 41°F (5°C).

Beater Motor

Shake: 1.0 hp.

Soft Serve: 1.5 hp.

Refrigeration System

Shake: 11,000 BTU/hr.

Soft Serve: 9,500 BTU/hr.

Refrigerant: R449A. (BTUs may vary depending on compressor used.)

Main Compressor

Air-cooled machines:

Shake: 52 oz. (1,474 g) of R449A.

Soft Serve: 46 oz. (1,304 g) of R449A.

Water-cooled machines:

Shake: 42 oz. (1,191 g) of R449A.

Soft Serve: 36 oz. (1,021 g) of R449A.

Note: *Specifications are subject to change. Check the data label for proper charging specifications.*

Electrical

Standard is 208/230-60-3; however, other electrical characteristics are available. Each machine requires electrical service:

Three-phase maximum fuse size: 45A

Minimum wire ampacity: 35A

Note: *McDonald's specifies Hubbell A460P9 plug for 208-230/60-3 machines.*

Air-Cooled

Clearance: A minimum of 3 in. (76 mm) is required around all sides. Install the deflector provided to prevent recirculation of warm air. Adequate airflow is required for optimum performance.

Dimensions

Width: 25-1/4 in. (641 mm)

Including cup/cone dispenser: 32-3/8 in. (822 mm)

Height: 60-7/16 in. (1,535 mm)

Depth: 38-7/8 in. (987 mm)

Floor clearance: 4-3/4 in. (121 mm)

Approximate Weights

Net: 815 lb (369.7 kg)

Crated: 1,022 lb (463.6 kg)

Volume: 67.4 cu. ft. (1.91 cu. m)

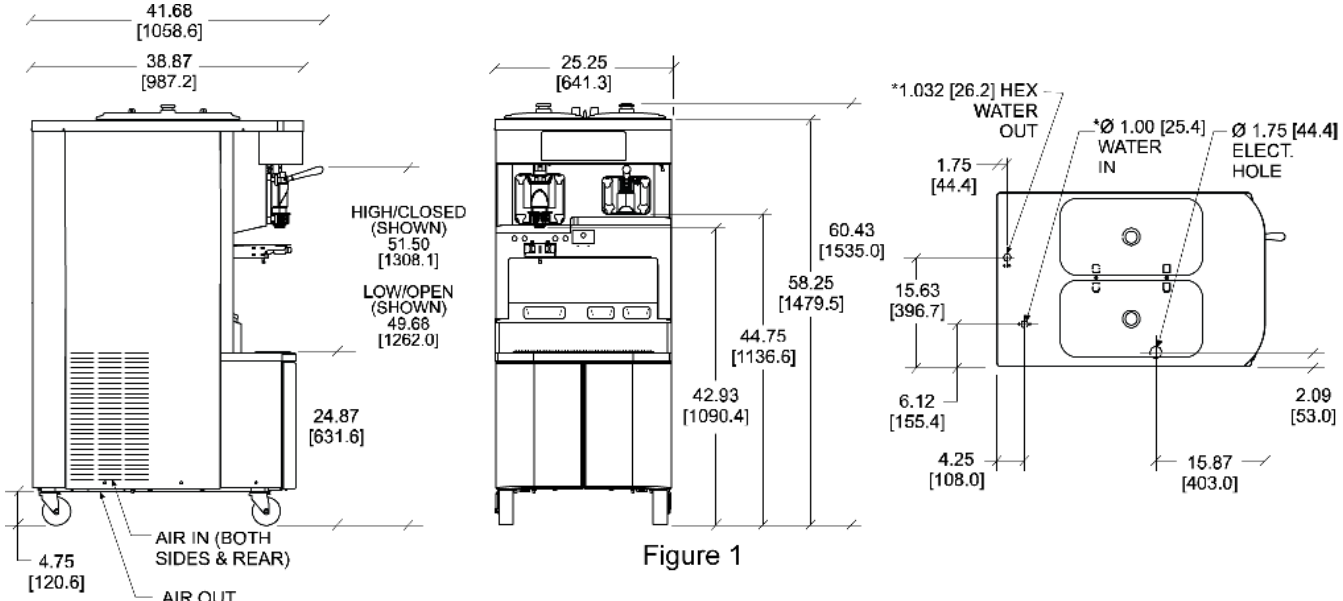

FIGURES IN BRACKETS INDICATE MILLIMETERS / DECIMAL AND FRACTIONAL DIMENSIONS EQUAL TO (PLUS OR MINUS 1/16 INCH [1.5mm] / *WATER COOLED ONLY).

TOP VIEW - OPERATOR END
ALL CONNECTIONS LOCATED UNDERSIDE OF BASE



150520

Figure 1-1

General Installation Instructions

NOTICE! Only trained, authorized service technicians should install this machine. Failure to comply will void the factory warranty.

1 The following are general installation instructions. For complete installation details, please see the checkout card.



IMPORTANT! All wiring and plumbing must conform to national and local codes.



IMPORTANT! A backflow prevention device is required on the incoming water connection side. Please see the applicable national, state, and local codes for determining the proper configuration. Water pressure to the unit must not exceed 150 psi (1034 kPa).

Site Preparation

Inspect the area where the machine will be installed before uncrating it. Make sure that all possible hazards to the user and the machine have been addressed.



CAUTION! This machine must be placed on a level surface. Failure to comply may result in personal injury or machine damage.



WARNING! Only install this machine in a location where its use and maintenance is restricted to trained personnel. Failure to comply may result in personal injury.



WARNING! This machine must **NOT** be installed in an area where a water jet or hose can be used. **NEVER** use a water jet or hose to rinse or clean the machine. Failure to follow this instruction may result in electrocution.

Uncrate the machine and inspect it for damage. Report any damage to your Taylor distributor.

For Indoor Use Only: This machine is designed to operate indoors, under normal ambient temperatures of 70°F to 75°F (21°C to 24°C). The freezer has successfully performed in high ambient temperatures of 104°F (40°C) at reduced capacities.

This machine is made in the USA and uses USA hardware sizes. All metric conversions are approximate.



IMPORTANT! In all areas of the world, machines should be installed in accordance with existing local codes. Please contact your local authorities if you have any questions.

Care should be taken to ensure that all basic safety practices are followed during the installation and servicing activities related to the installation and service of Taylor machines.

- Only Taylor service personnel should perform installation, maintenance, and repairs on Taylor machines.
- Authorized service personnel should consult OSHA Standard 29CFR1910.147 or the applicable code of the local area for the industry standards on lockout/tagout procedures before beginning any installation or repairs.
- Authorized service personnel must ensure that the proper personal protective equipment (PPE) is available and worn when required during installation and service.
- Authorized service personnel must remove all metal jewelry, rings, and watches before working on electrical equipment.

Air-Cooled Machines

These machines require a minimum of 3 in. (76 mm) of air clearance around all sides. Install the deflector provided to prevent recirculation of warm air. Minimum air clearances must be met to assure adequate airflow for optimum performance.

Water Connections (Water-Cooled Machines Only)

An adequate cold water supply must be provided with a hand shut-off valve. On the underside of the base pan or on the right side, two 3/8" I.P.S. water connections for inlet and outlet are provided for easy hook-up. Permanently connect the machine using 1/2 in. (12.7 mm) inside diameter water lines.

Flexible hose sets are recommended if local codes permit. In Europe, hose sets for connection of appliances to the water mains must comply with the international IEC 61770 standard.

The water expansion valve setting of the machine (high side) is to be set at 250 psig to 260 psig (17.2 bar to 17.9 bar). The recommended low-side setting is 27 psig to 29 psig (1.86 bar to 2.0 bar). Please consult the expansion valve tag connected to the machine to verify.

Depending on local water conditions, it may be advisable to install a water strainer to prevent foreign substances from clogging the automatic water valve. There will be only one water-in and one water-out connection.

Do not install a hand shut-off valve on the water-out line. Water should always flow in this order: first, through the automatic water valve; second, through the condenser; and third, through the outlet fitting to an open trap drain.



IMPORTANT! A backflow prevention device is required on the incoming water connection side. Please see the applicable national, state, and local codes for determining the proper configuration. Water pressure to the unit must not exceed 150 psi (1034 kPa).

Electrical Connections



IMPORTANT! In the United States, this machine is intended to be installed in accordance with the National Electrical Code (NEC), ANSI/NFPA 701987. The purpose of the NEC code is the practical safeguarding of persons and property from hazards arising from the use of electricity. This code contains provisions considered necessary for safety.

In all other areas of the world, the machine should be installed in accordance with the existing local codes. Please contact your local authorities if you have any questions.

Each machine requires one power supply for each data label on the machine. Check the data label(s) on the machine for branch circuit overcurrent protection or fuse, circuit ampacity, and other electrical specifications.

See the wiring diagram provided inside the electrical box for proper power connections.



IMPORTANT! This machine is provided with an equipotential grounding lug that is to be properly attached to either the rear of the frame or the underside of the base pan near the entry hole for incoming power, by the authorized installer. The installation location is marked by the equipotential bonding symbol (5021 of IEC 60417-1) on both the removable panel and the machine's frame, as well as on the diagram.



- IMPORTANT!**
- Stationary machines which are not equipped with a power cord and a plug or another device to disconnect the machine from the power source must have an all-pole disconnecting device with a contact gap of at least 0.125 in. (3 mm) installed in the external installation.
 - Machines that are permanently connected to fixed wiring and for which leakage currents may exceed 10 mA, particularly when disconnected or not used for long periods, or during initial installation, shall have protective devices, to protect against the leakage of current such as a GFI, installed by the authorized personnel to the

INTRODUCTION

local codes.

- Supply cords used with this machine shall be oil-resistant, sheathed flexible cable not lighter than ordinary polychloroprene or other equivalent synthetic elastomer-sheathed cord (code designation 60245 IEC 57) installed with the proper cord anchorage to relieve conductors from strain, including twisting, at the terminals and protect the insulation of the conductors from abrasion.
- If the supply cord is damaged, it must be replaced by a Taylor service technician in order to avoid a hazard.
- Secure the supply cord ground lead to the machine in a location where if the cord is pulled, the main power leads will become taut before the ground lead can break loose.

Failure to follow these instructions may result in electrocution or damage to the machine.

Beater Rotation

Beater rotation must be **clockwise** when viewed from the front of the machine.

Note: This machine is equipped with an interlock circuit that prevents beater motor operation when the freezer door is not installed.



WARNING! Make sure the power switch is in the OFF position. Failure to follow this instruction may result in severe personal injury from hazardous moving parts.

1. Remove the door assembly, beater, and scraper blades.
2. Place the power switch in the ON position.
3. Place a magnet over the door switch in the front panel. This deactivates the safety feature which prevents the operation of the machine when the door is not installed.
4. Press the WASH key. This activates the beater motor only.



CAUTION! Hazardous Moving Parts.

Keep your hands clear when operating the machine with the panels removed. Failure to follow this instruction may result in severe personal injury from hazardous moving parts.

5. Look into the freezing cylinder. The drive shaft should be turning **clockwise**.
6. Press the WASH key to discontinue beater motor operation.



CAUTION! Disconnect all power to the machine. Failure to follow this instruction may result in electrocution.

If the beater rotation must be corrected, perform the following:

To correct rotation on a three-phase machine, interchange any two of the T1, T2, or T3 on the load side of the beater motor contactor. Repeat step 1 through step 7 for the other side of the machine.

To correct rotation on a single-phase machine, change the leads inside the beater motor by following the diagram printed on the motor label.

Gear Alignment and Rear Shell Bearing

1. Make sure the driveshaft can easily slide in and out of the female socket on the gear unit.
2. If a driveshaft is binding, the gear unit could be out of alignment (loose). Check the bolts on the gear unit to make sure they are tight.
3. Inspect the rear shell bearing for tightness. Be sure the locking tab has been folded over to prevent the nut from loosening.

Note: If the gear unit is out of alignment, refer to the *General Service Manual*.

Pump Motor Rotation

1. Remove the air/mix pump assembly.
2. Connect power to the freezer and place the power switch in the ON position.
3. Press the PUMP key on the control panel. This will activate the pump motor only.
4. Observe the pump ball crank. It should be rotating counterclockwise.

If rotation is not correct, refer to the wiring diagram on the pump motor and re-wire accordingly.

Refrigerant



CAUTION! This machine contains fluorinated greenhouse gases (F-Gas) to provide refrigeration using a hermetically sealed circuit or within foam insulation. The type of gas, quantity, Global Warming Potential (GWP) and CO₂ tonnes equivalent information is recorded on the machine's data-label. The refrigerant used is generally considered non-toxic and non-flammable. However, any gas under pressure is potentially hazardous and must be handled with caution.

NEVER fill any refrigerant cylinder completely with liquid. Filling the cylinder to approximately 80% will allow for normal expansion



CAUTION! Use only approved refrigerant listed on the machine's data-label or authorized through a manufacturer's technical bulletin. The use of any other refrigerant may expose users and operators to unexpected safety hazards.



WARNING! Refrigerant liquid sprayed onto the skin may cause serious damage to tissue. Keep eyes and skin protected. If refrigerant burns should occur, flush the area immediately with cold water. If burns are severe, apply ice packs and contact a physician immediately.



NOTICE! Taylor reminds technicians to be aware of government laws regarding refrigerant recovery, recycling, and reclaiming systems. If you have any questions regarding these laws, please contact the factory service department.



IMPORTANT! Refrigerants and their associated lubricants may be extremely moisture absorbent. When opening a refrigeration system, the maximum time the system is open must not exceed 15 minutes. Cap all open tubing to prevent humid air or water from being absorbed by the oil.

Compressor Warranty Disclaimer

1 The refrigeration compressor(s) on this machine are warranted for the term indicated on the warranty card accompanying this machine. However, due to the Montreal Protocol and the U.S. Clean Air Act Amendments of 1990, many new refrigerants are being tested and developed; thus seeking their way into the service industry. Some of these new refrigerants are being advertised as drop-in replacements for numerous applications. It should be noted that, in the event of ordinary service to this machine's refrigeration system, only the refrigerant specified on the affixed data label should be used. The unauthorized use of alternate refrigerants will void your compressor warranty. It will be the owners' responsibility to make this fact known to any technicians they employ.

It should be noted that Taylor does not warrant the refrigerant used in its machines. For example, if the refrigerant is lost during the course of ordinary service to this machine, Taylor has no obligation to either supply or provide its replacement either at billable or unbillable terms. Taylor does have the obligation to recommend a suitable replacement if the original refrigerant is banned, obsoleted, or no longer available during the five-year warranty of the compressor.

Taylor will continue to monitor the industry and test new alternates as they are being developed. Should a new alternate prove, through our testing, that it would be accepted as a drop-in replacement, then the above disclaimer would become null and void. To find out the current status of an alternate refrigerant as it relates to your compressor, call the local Taylor distributor or the Taylor factory. Be prepared to provide the model/serial number of the machine in question.

Environmental Notices



CAUTION! This equipment contains fluorinated greenhouse gases (F-Gas) to provide refrigeration using a hermetically sealed circuit or within foam insulation. This unit's type of gas, quantity, Global Warming Potential (GWP) and CO₂ tonnes equivalent information is recorded on the unit's data label. The refrigerant used is generally considered non-toxic and non-flammable. However any gas under pressure is potentially hazardous and must be handled with caution.

NEVER fill any refrigerant cylinder completely with liquid. Filling the cylinder to approximately 80% will allow for normal expansion.



IMPORTANT! *If the crossed-out wheeled bin symbol is affixed to this machine, it signifies that this machine is compliant with the EU directives as well as other similar end-of-life legislation in effect after August 13, 2005. Therefore, it must be collected separately after its use is completed and cannot be disposed as unsorted municipal waste.*

The user is responsible for delivering the machine to the appropriate collection facility, as specified by your local code.

For additional information regarding applicable local disposal laws, please contact the municipal waste facility and/or local authorized Taylor distributor.

For Indoor Use Only: This machine is designed to operate indoors, under normal ambient temperatures of 70°F to 75°F (21°C to 24°C). The freezer has successfully performed in high ambient temperatures of 104°F (40°C) at reduced capacities.

Noise Level: Airborne noise emission does not exceed 78 dB(A) when measured at the distance of 39 in. (1.0 m) from the surface of the machine and at a height of 63 in. (1.6 m) from the floor.

1

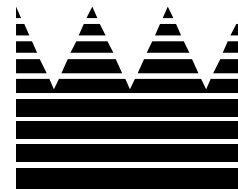

Section 2: Controls

- **Running Specifications**
- **Remote Monitoring Commissioning**
- **Refrigeration System Schematic**
- **Control Panel Functions**
- **Freezer Lockout**
- **Service Menu**
- **Heat Treatment**
- **Timers**
- **Glycol**
- **Setting Viscosity**
- **Portion Control (Shake)**
- **Adjustable Draw Handle**
- **Universal Control Overview**
- **Universal Control**
- **LONWorks® Gateway**
- **Electrical System**
- **Shake Draw**
- **Shake Dispensing Alignment Procedure**
- **Syrup**

Running Specifications

Pressures/Temperatures

The following are the Taylor recommended settings for various components in the Model C602. (See “Refrigeration System Schematic” on page 2-5.)

Expansion Valve

Soft Serve

2 Air-cooled: 20 psi to 22 psi (138 kPa to 152 kPa).
Water-Cooled: 20 psi to 22 psi (138 kPa to 152 kPa) for a normal product of 16°F to 18°F (-8.8°C to -7.7°C).

Shake

Air-cooled: 31 psi to 33 psi (214 kPa to 228 kPa)
Water-cooled: 31 psi to 33 psi (214 kPa to 228 kPa) for a normal product of 24°F to 26°F (-4°C).

Note: Triple Thick Shake product temperature is 22°F to 24°F (-5°C).

Expansion Valve Adjustment

Connect your refrigerant gauge to the low-side access valve. Turn the access valve counterclockwise to open the valve.

Adjust the pressure with the expansion valve adjustment screw. Turn clockwise to raise the pressure, or counterclockwise to lower the pressure.

Note: Make expansion valve adjustments with mix in the freezing cylinder and the freezer in the Auto mode. Be sure to allow adequate time for the pressure to stabilize.

Turn the access valve clockwise to close the valve. Install and securely tighten the access valve caps and the expansion valve cap.

Low-Side (Suction)

Low-side pressure is controlled by the expansion valve setting.

High-Side (Discharge)

High-side pressure varies for air-cooled machines, depending on the ambient temperature.

Table 2-1

Ambient Temperature		Normal Operating Head Pressures
°F	°C	psi (kPa)
70°	21.1°	240 to 270 (1,655 to 1,862)
80°	26.7°	270 to 300 (1,862 to 2,069)
90°	32.2°	300 to 340 (2,069 to 2,344)
100°	37.8°	340 to 380 (2,344 to 2,620)

Water Valve

On a water-cooled machine, the water valve should be set to maintain a compressor head pressure of 255 psi (1,758 kPa).

Water Valve Adjustment

Note: Make this adjustment with mix in the cylinder and the freezer in the Auto mode. Be sure to allow adequate time for pressure to stabilize.

Connect your refrigerant gauge to the high-side access valve. Turn the access valve counterclockwise to open the valve. Turning the adjustment stem on the water valve clockwise will lower the pressure.

Turn the access valve clockwise to close the valve. Install and securely tighten the access valve caps.

Remote Monitoring Commissioning

Taylor Gateway Connecting to Wi-Fi

1. From Taylor machine enable Gateway Access Point:
 - a. Enter the Manager Menu.
 - b. Scroll down to Enable Wi-Fi menu.
 - c. Enable the feature.
 - d. This will activate the Gateway Access Point for 10 minutes, allowing a user to connect directly to the Gateway.
2. From a user device (laptop, cellphone, tablet, etc.) connect to the taylor-gw access point through the Wi-Fi setting on the device.
 - a. This access point may not be broadcast so the user may have to use the Add Network function.
 - b. Enter the password to connect to the access point.
3. Once the connection is established open an internet browser.
4. Enter 192.168.2.1:8081 into the browser bar.
 - a. A warning page may be displayed (examples follow).
 - b. This warning is due to the configuration page's certificate and it is ok to proceed.
 - c. By clicking Details or Advanced the user can proceed to the URI despite the warning.

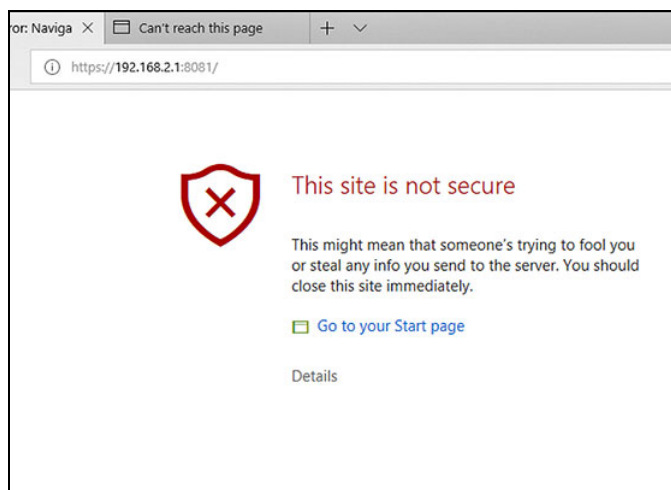

Figure 2-1

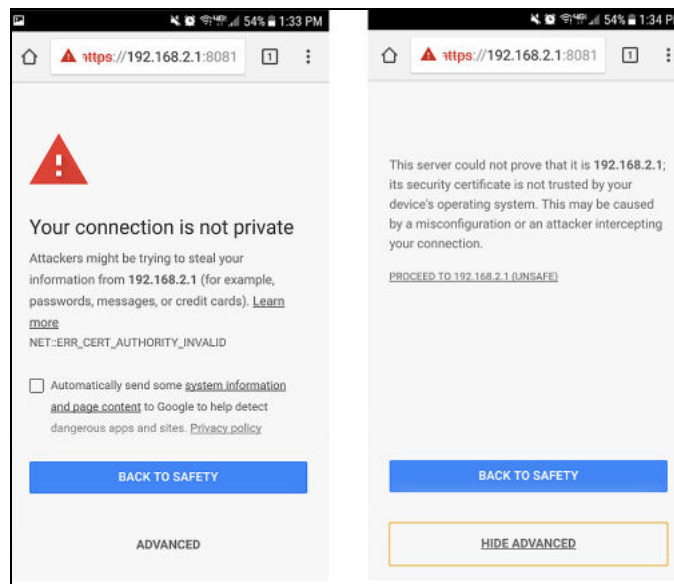

Figure 2-2

- d. The Gateway configuration webpage will then be displayed.

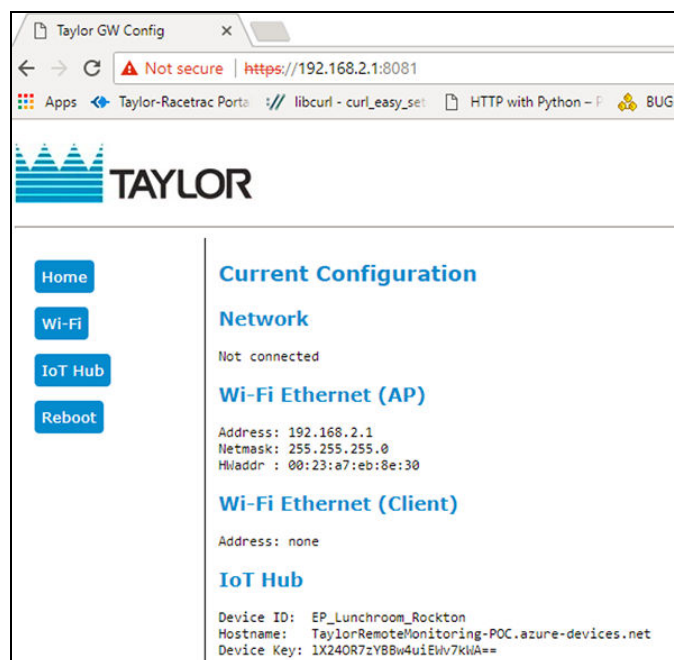

Figure 2-3

5. Click on the Wi-Fi tab:
 - a. Enter the name of the customer Access Point you would like to connect to (Customer's Wi-Fi).
 - b. Enter the corresponding password.
 - c. Click Submit to save the changes.
 - d. Click reboot to reboot the Gateway, at which time it will connect to the customer's Wi-Fi.

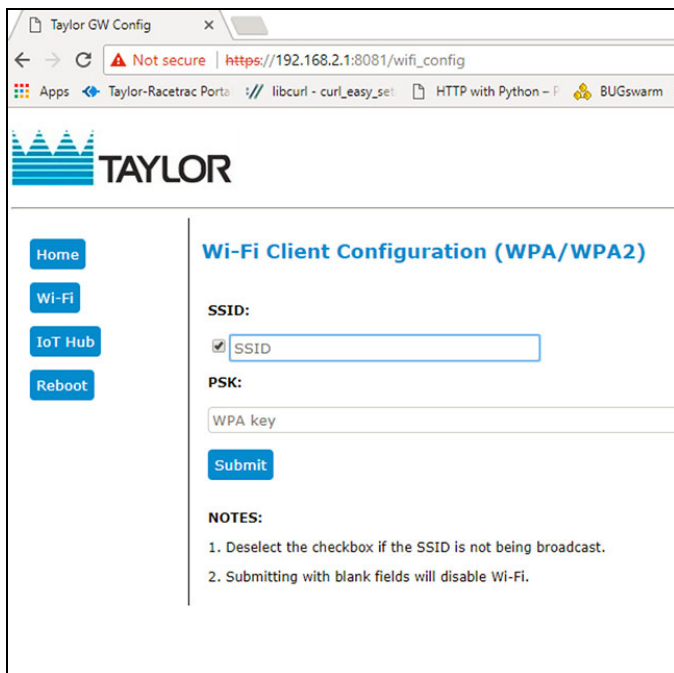

Figure 2-4

6. Confirm connection to customer access point (Wi-Fi).

Remote Monitoring Gateway Board

Troubleshooting

To troubleshoot issues with the remote monitoring gateway board, observe the blink patterns of the blue LED light at D1. The light will illuminate for approximately 1 second, followed by the code blinks.

LED not lit: No power to the gateway board

- Confirm there is 24V to the power cable at the connector end.
- Confirm the power cable is correctly connected to the transformer.
- Replace the gateway board.

2 blinks: No communication between gateway and UVC4 boards

- Confirm the cable between the gateway and UVC4 boards is connected properly and not damaged.
- Confirm UVC4 is functioning correctly.
- Confirm the UVC4 has the correct software version for remote monitoring system:
 - C602: Minimum version 2.03

3 blinks: WiFi error

- Confirm the store's WiFi is operational:
 - Using a computer, tablet, or phone, try to connect to any website on the store's WiFi.
- Confirm store's current WiFi password:
 - If recently changed, follow the procedures to reconnect the gateway board to the store's WiFi.
- Confirm the store's current SSID (WiFi name):
 - If recently changed, follow the procedures to reconnect the gateway board to the store's WiFi.
- Confirm the WiFi signal strength using an app on a phone or tablet:
 - Minimum DB level -70 dBm
 - Suggested apps
 - Android : WiFi Analyzer
 - iOS: AirPort Utility

Note: Go to app settings and turn on WiFi Scanner options.

4 blinks: Server connection error

- Follow the procedures to reconnect the gateway board to the store's WiFi.

Replace the gateway board.

Refrigeration System Schematic

2

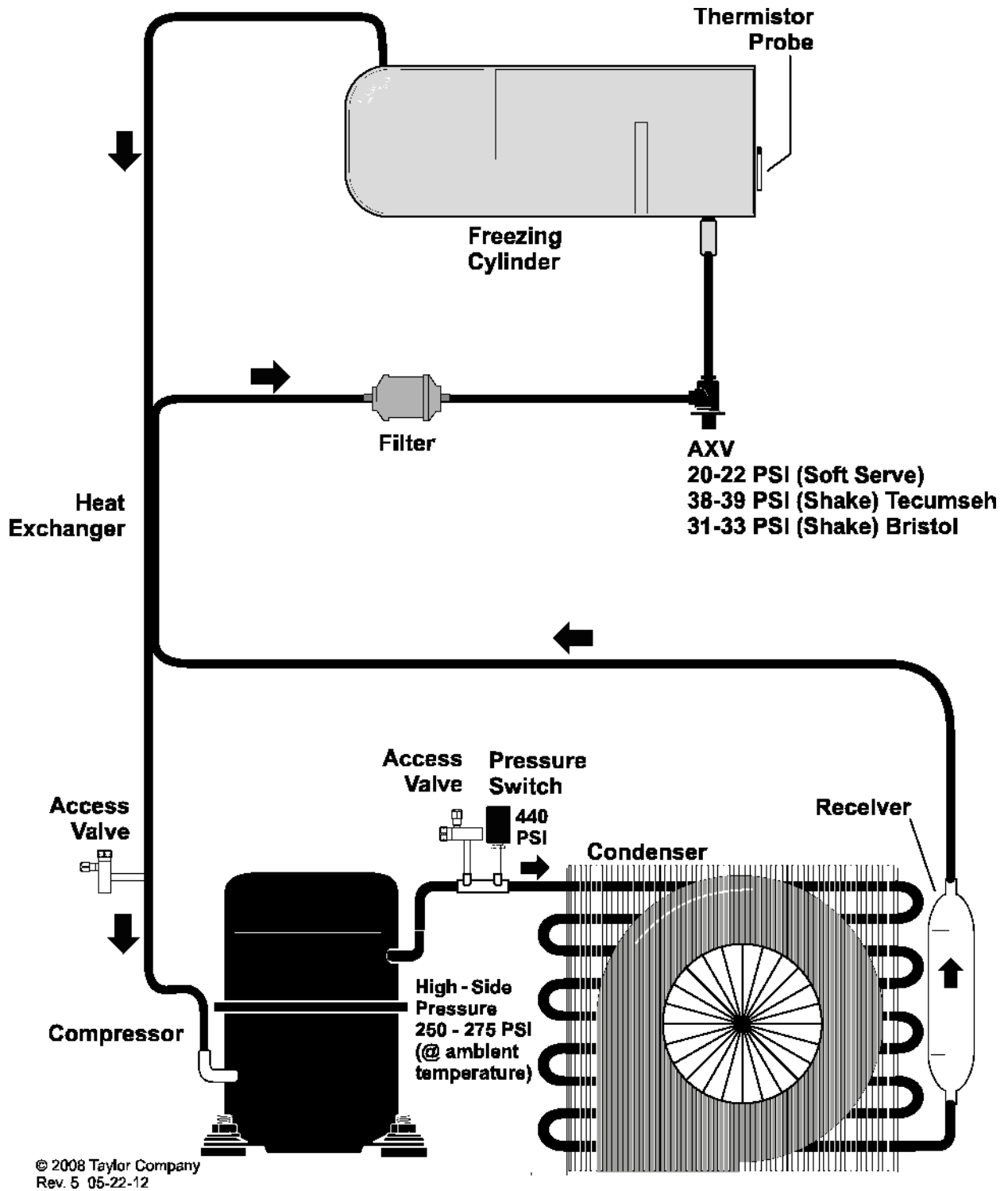

Figure 2-5

Control Panel Functions

2

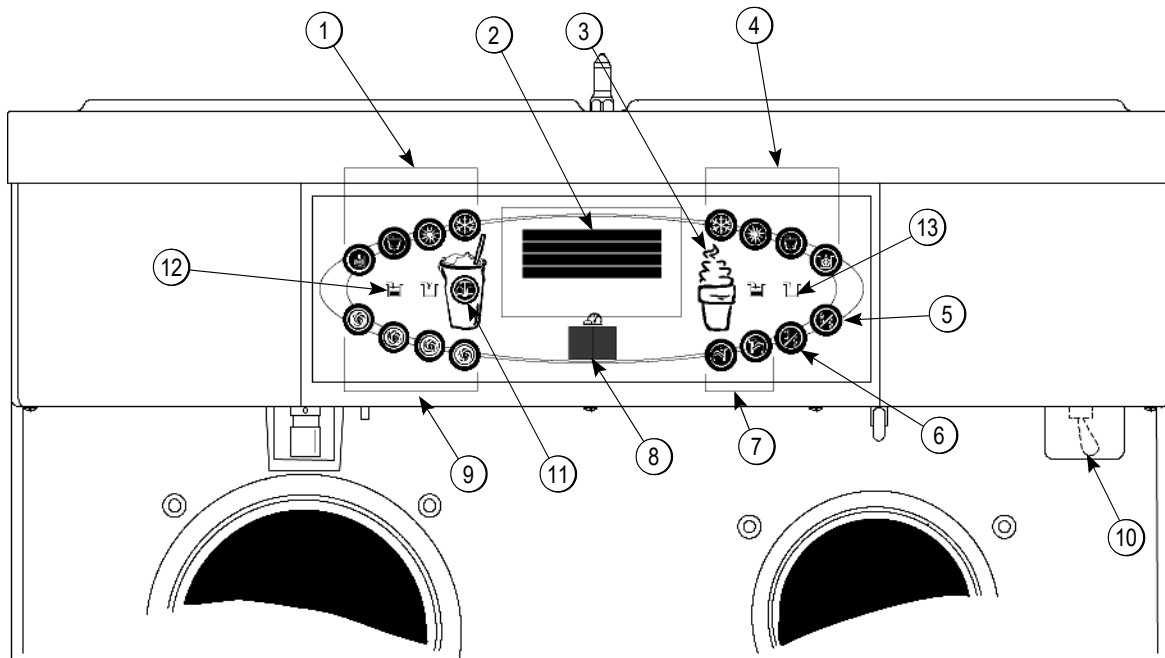





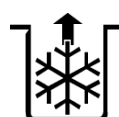



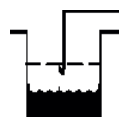
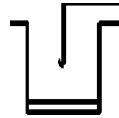

Figure 2-6



Item	Description	Function
1	Keypad-Shake	Used for selecting operating functions on the shake side of the machine.
2	Display-Vacuum Fluorescent Menu (VFD)	Screen which displays menu options and notifies operator if a fault is detected.
3	Keypad-Menu (Entry/Exit)	Used to select the Manager or Service Menu or to exit the menu display.
4	Keypad-Soft Serve	Used for selecting operating functions on the soft serve side of the machine.
5	Standby-Soft Serve	Indicates when the soft serve side is in the Standby mode.
6	Standby-Shake	Indicates when the shake side is in the Standby mode.
7	Keypad-Topping Heater	Used to activate the topping rail heaters.
8	Display-LED Dual (Brush-Clean Countdown)	Displays the number of days before brush-cleaning is required.
9	Keypad-Flavor Select	Used for selecting the desired shake flavor to be dispensed. Also used for opening and closing the draw valve when cleaning, sanitizing, and priming the shake side.
10	Switch-Power	When placed in the ON position, allows control panel operation.
11	Keypad-Calibrate Menu	Used to access the Calibrate Menu containing options for calibrating the syrup dispensing rate or priming and flushing the syrup lines.
12	Indicator Light-Mix Low	Illuminates when the mix hopper has a low supply of mix; should be refilled as soon as possible.
13	Indicator Light-Mix Out	Illuminates when the mix hopper has an insufficient supply of mix to operate the freezer. The Auto mode will be locked out and the machine will be placed in the Standby mode.

Symbol Definitions

To better communicate in the international arena, the words on many of the operator keys have been replaced by symbols to indicate their function. Your Taylor machine is designed with these international symbols.

The following chart identifies key functions:

-  = Auto
-  = Heat Cycle
-  = Wash
-  = Mix Pump
-  = Standby (Shake)
-  = Standby (Soft Serve)
-  = Flavor Selection
-  = Mix Low
-  = Mix Out
-  = Topping Heater-Left

-  = Topping Heater-Right
-  = Calibrate
-  = Menu Display

Power Switch

When placed in the ON position, the power switch allows control panel operation.

Vacuum Fluorescent Display

The vacuum fluorescent display (VFD) is located on the front control panel. During normal operation, the display is blank. The display shows menu options and notifies the operator if a fault is detected. On international models, the display will indicate the temperature of the mix in each hopper.

Indicator Lights

Mix Low - When the Mix Low  key is illuminated, the mix hopper has a low supply of mix and should be refilled as soon as possible.

Mix Out - When the Mix Out  indicator is illuminated, the mix hopper has been almost completely exhausted and has an insufficient supply of mix to operate the freezer. At this time, the Auto mode is locked out and the freezer is placed in the Standby mode. To initiate the refrigeration system, add mix to the mix hopper and

press the Auto key . The freezer will automatically begin operation.

Heat Cycle Key

When the Heat Cycle key  is illuminated, the freezer is in the process of a heat treatment cycle. The Heat Cycle key may be selected to start a heat treatment cycle following a freezer soft lock condition.

For some international models, the Heat Cycle key can be selected to manually start a heat cycle at any time.

Brush-Clean Countdown - Displays the number of days before the next brush-cleaning is required. When the display has counted down to 1, the machine must be disassembled and brush-cleaned within 24 hours.

Power Up

When the machine is powered up, the control system will initialize to perform a system check. There are four types of data that the system will check when the control is initializing: Lamp Test, Lockout Data, Configuration Data, and System Data. (See Figure 2-7.)

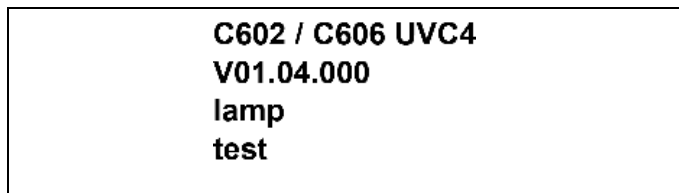

Figure 2-7

Lamp Test: The control and software version is displayed and all of the LEDs on the display panel are illuminated. (See Figure 2-8.)

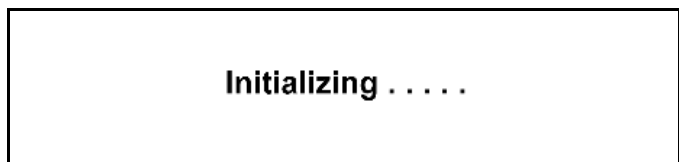

Figure 2-8

Following the lamp test, three separate screens will appear during initialization:

- Initializing Lockout Data
- Initializing Config Data
- Initializing System Data

During the initializing sequence, if the system detects corrupt data, the following display will alert the operator that the control settings have changed:

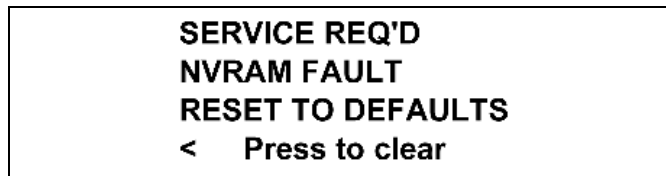

Figure 2-9

Once the system has initialized, the number of days remaining before the next brush-cleaning is indicated on the control panel, and the SAFETY TIMEOUT screen is displayed with the audible alarm activated. (See Figure 2-10.)



Figure 2-10

The SAFETY TIMEOUT screen will be displayed, with the alarm on, for 60 seconds or until any control key is selected.

After the safety timeout has been completed and the power switch is OFF, the status screen will display. When the brush-clean requirements have been met, the following screen will display:

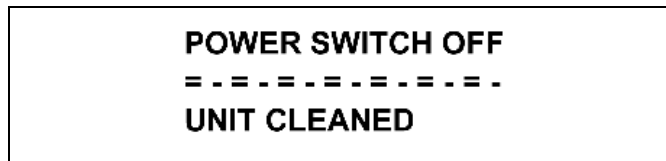

Figure 2-11

If a brush-cleaning was not completed, the status screen displays the current hopper temperature, barrel temperature, and the 5-minute brush-clean timer. (See Figure 2-12.)

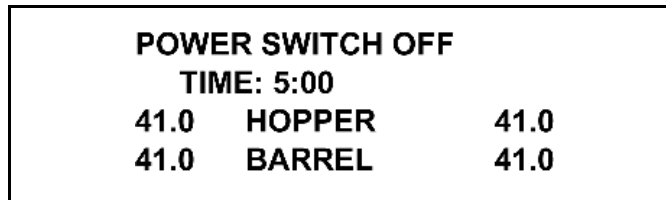

Figure 2-12

2

Power Switch ON

When the power switch is placed in the ON position, the control panel touch keys become operative. The display will be either blank or indicate that the machine has been cleaned. (See Figure 2-13.)



Figure 2-13

Display for International Models Only:

Some international models will continuously display the temperature of each mix hopper when the power switch is in the ON position. (See Figure 2-14.)

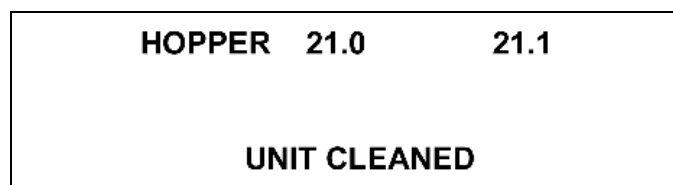



Figure 2-14

Heat Treatment Cycle

The Heat Cycle keys  on the control panel are illuminated throughout the heat treatment cycle. Two warning messages will be displayed on the screen. DO NOT DRAW is displayed when the mix temperature is below 130°F (54.4°C). (See Figure 2-15.)

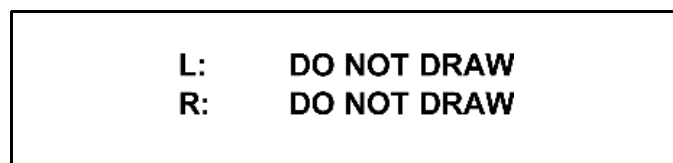

Figure 2-15

When the temperature of the mix is above 130°F (54.4°C), the screen will display HOT PRODUCT. (See Figure 2-16.)



Figure 2-16



WARNING! DO NOT attempt to draw product or disassemble the machine during the heat treatment cycle (if equipped). The product is hot and under extreme pressure. Severe burns from hot product may result if this instruction is not followed.

In the heat treatment cycle, the mix temperature in the hoppers and freezing cylinders must be raised to 151°F (66.1°C) within 90 minutes.

When the Heat phase is complete, the freezer goes into the Hold phase of the cycle which keeps the temperature above 151°F (66.1°C) for a minimum of 30 minutes.

The final phase of the heat treatment cycle is the Cool phase. The freezer must cool the mix below 41°F (5°C) within 2 hours.

When the entire heat cycle has been completed, the Heat

Cycle keys  will no longer be illuminated. The

machine will enter the Standby mode (Standby keys )

and  illuminate). The machine can be placed in Auto mode or left in Standby.

Brush-Clean Requirements

Placing the power switch in the Off position displays the 5-minute brush-clean timer and the current freezing cylinder and hopper temperatures.

The timer begins when the following conditions for a successful brush-cleaning are met:

- a. Mix Low/Mix Out condition.
- b. Hopper and freezing cylinder temperatures are above 60°F (15.6°C).
- c. Both freezer doors were removed concurrently.

Freezer Lockout

Heat Cycle Failure Messages

To comply with health codes, heat treatment system freezers **must** complete a heat treatment cycle daily, and **must** be disassembled and brush-cleaned a minimum of every 28 days. Brush-cleaning is the normal disassembly and cleaning procedure found in the Operator's Manual. Failure to follow these guidelines will cause the control to lock the freezer out of the Auto mode.

2 Always comply with local guidelines for the maximum number of days allowed between brush-clean cycles. (See "BRUSH-CLEAN CYCLE" on page 2-20.)

If the heat treatment cycle fails, the display shows a failure message and returns the freezer to the Standby mode. A lock is defined as a special Standby mode of operation which does not allow the machine to operate in the Auto mode.

There are two types of freezer lock conditions that can occur: hard lock or soft lock. A hard lock requires the machine be disassembled and brush-cleaned. A soft lock can be corrected by either is assembling and brush-cleaning the machine, or by starting another heat treatment cycle.

Hard Lock: There are two causes of a hard lock failure:

1. The brush-clean timer has elapsed (maximum setting of 28 days). (See Figure 2-17.)

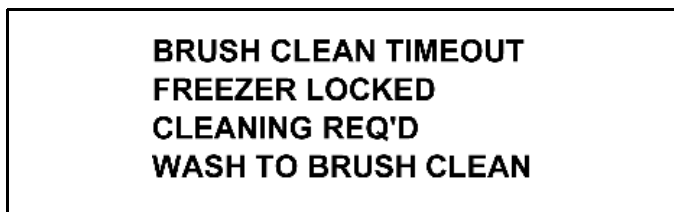

Figure 2-17

Selecting the Wash key displays the following screen:

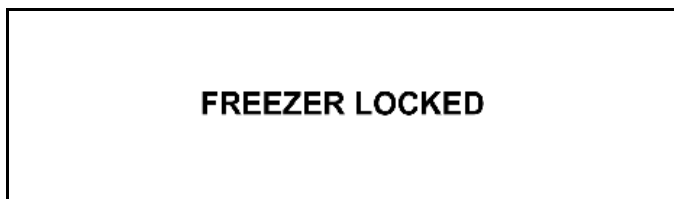

Figure 2-18

2. There has been a thermistor failure (freezing cylinder, hopper, or glycol) during the heat treatment process. (See Figure 2-19.)

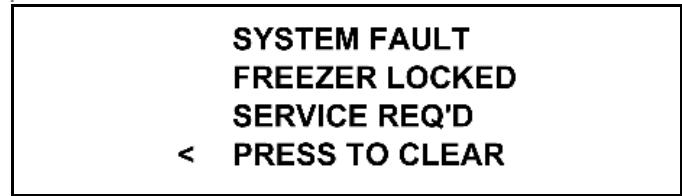

Figure 2-19

Selecting the Calibrate key will show which thermistor caused the hard lock. (See Figure 2-20.)

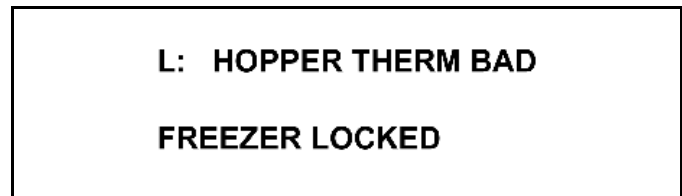

Figure 2-20

If the machine has hard locked and an attempt is made to enter Auto mode, the machine will enter the Standby mode and display the following message. (See Figure 2-21.)

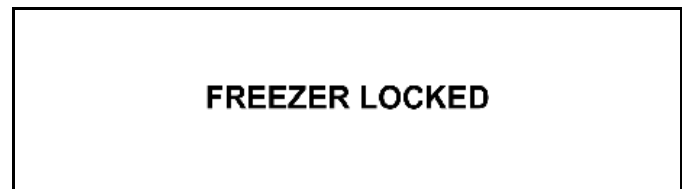

Figure 2-21

To restore the message that identified the reason for the hard lock, turn the power switch to OFF for 5 seconds and then return the power switch to ON. The original message with the reason for the hard lock will be displayed. The fault description can also be found in the Manager or Service Menu. (See "FAULT DESCRIPTION" on page 2-21.)

The FREEZER LOCKED message will remain on the display until the brush-clean requirements are fulfilled. The freezer must be disassembled in order to activate the 5-minute timer on the display screen. Once the timer counts down to zero, the lockout is cleared.

Soft Lock: If a heat treatment cycle has not been initiated within the last 24 hours, a soft lock failure will occur. A soft lock allows the operator to correct the cause of the soft lock. The operator has the option of either

starting another heat treatment cycle or brush-cleaning the machine. When a soft lock occurs, the machine will go into the Standby mode. The following message is displayed on the screen; the reason for the soft lock is indicated on the second line. (See Figure 2-22.)



Figure 2-22

If the reason for the soft lock has been corrected,

selecting the Heat Cycle key  initiates a heat treatment cycle immediately. Selecting the Wash key

when the above message is displayed will hard lock the machine. Brush-cleaning will be necessary.

Reasons For Soft Lock

Following are the variable messages for soft lock failures that appear on the second line of the screen.

Power Switch Off

This soft lock will occur if the power switch is in the OFF position and more than 24 hours have passed since the start of the 28-day timer, or the start of the last successful heat treatment cycle.

Mix Out

This soft lock will occur if one or both sides has a mix out condition and more than 24 hours have passed since the start of the 28-day timer or the start of the last successful heat treatment cycle.

Auto or Standby Off

This soft lock will occur if one or both sides is in the OFF mode and more than 24 hours have passed since the start of the 28-day timer or the start of the last successful heat treatment cycle.

No Heat Cycle Tried

No heat treatment cycle was performed in the 24 hours after the start of the 28-day timer, or the start of the last successful heat treatment cycle. (Auto Heat Time was advanced, a power loss was experienced at the time the cycle was to occur, or a heat treatment cycle failure not

due to a thermistor failure.)

If the following screen appears, a soft lock has occurred during the heat treatment cycle. (See Figure 2-23.)

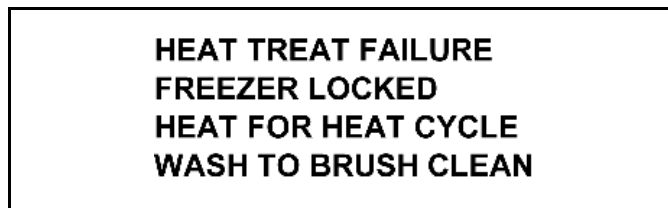



Figure 2-23

A soft lock can also occur any time during operation when the hopper or freezing cylinder temperature rises above 59°F (15°C), the temperature rises and remains above 41°F (5°C) for more than 4 hours, or the temperature rises and remains above 45°F (7°C) for 1 hour. If a PRODUCT OVER TEMP condition occurs during operation, the following screen will appear:



Figure 2-24

When one of these messages appears, automatic freezer operation cannot take place until the freezer is disassembled and brush-cleaned, or has completed a

heat treatment cycle. Select the Heat Cycle key  to

start a heat cycle, or select the Wash key  to disassemble and brush-clean the machine.

Once the freezer is unlocked by starting a heat treatment

cycle, the Heat Cycle key  will illuminate and the following message will be displayed on the screen:

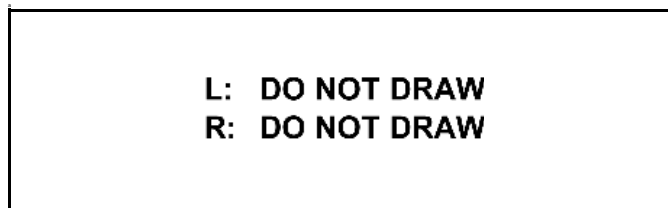

Figure 2-25

If the Wash key is selected to clear the lockout by brush-cleaning the machine, the FREEZER LOCKED message will remain on the display until the brush-clean requirements are fulfilled. The freezer must be disassembled in order to activate the 5-minute timer on the display screen. Once the timer counts down to zero, the lockout is cleared. (See Figure 2-26.)

2



FREEZER LOCKED

Figure 2-26

To restore the message that identified the reason for the soft lock, turn the power switch to OFF for 5 seconds, and then return the power switch to ON. The original message with the reason for the soft lock will be displayed. (See Figure 2-27.)



**HEAT TREAT FAILURE
REASON
HEAT FOR HEAT CYCLE
WASH TO BRUSH CLEAN**

Figure 2-27

The fault description can also be found in the Manager and Service Menus. (See “FAULT DESCRIPTION” on page 2-21.)

Note: *A record of heat cycle data and lockout history can be found in the Manager and Service Menus. (See “LOCKOUT HISTORY” on page 2-22.)*

Service Menu

The Service Menu option allows a trained service technician to access and modify critical operating parameters for the machine. All the menu screens found in the Manager Menu are also included in the Service Menu. To access the menu, touch the center of the Cone key . (See Figure 2-28.)

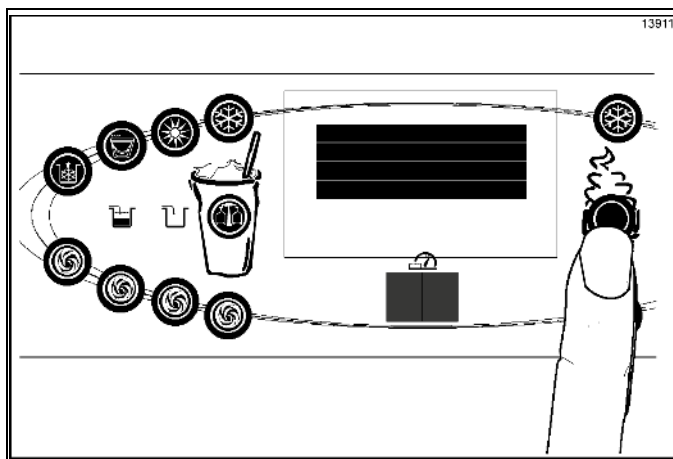











Figure 2-28

The left (shake-side) Auto key  and Flavor Selection

key , the Cone key , and the Calibration key  will be illuminated when the ENTER ACCESS CODE screen is displayed.

In the displayed menu, the left (shake-side) Auto key  and Flavor Selection key , and the Calibration key  will function as menu keys. Use the Cone key  to exit the menu.

The Auto key  increases the value above the cursor and used to scroll upward in text displays.



The Flavor Selection key  decreases the value above the cursor and scrolls downward in text displays.

The Calibration key  advances the cursor position to the right and is used to select menu options.

Note: You will not be able to dispense shakes while accessing the Service Menu options, except when the *CURRENT CONDITIONS* screen is displayed.

The soft serve side will continue operation in the mode it was in when the Menu was selected. However, the soft serve side control keys will not be illuminated and are non-functional when a menu screen is displayed. The control keys for both sides are only functional when the *CURRENT CONDITIONS* screen is displayed.

Entering the Access Code

1. With the ENTER ACCESS CODE screen on the display, use the Auto  or Flavor Selection keys  to set the first code number in the cursor position.
2. When the correct number is selected, touch the Calibration key  to move the cursor to the next number position.

The access code for the Service Menu is 5231. The access code for the Manager Menu is 8309. (See Figure 2-29.)

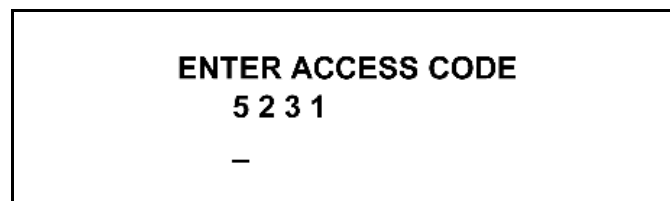



Figure 2-29

3. Continue to enter the proper access code numbers until all four numbers are displayed.
4. Press the Calibration key . The Service Menu list will display on the screen, provided the correct access code is entered.

CONTROLS

If an incorrect number is entered for the access code, the display will exit the Menu program when the

Calibration key  is selected. (See Figure 2-30.)

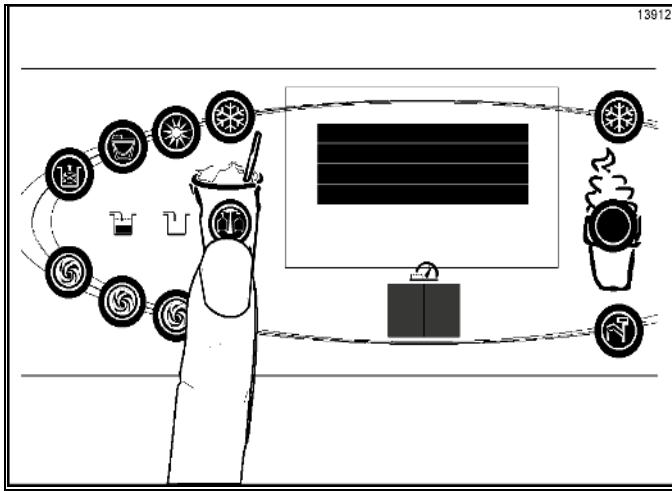





Figure 2-30

- FAULT DESCRIPTION
- FAULT HISTORY
- LOCKOUT HISTORY
- HEAT CYCLE SUMMARY
- HEAT CYCLE DATA
- SYSTEM INFORMATION
- CURRENT CONDITIONS
- NET SERVICE PIN
- TEMPERATURE SCALE
- STANDBY TEMPERATURE
- HOPPER TEMPERATURE
- GLYCOL TEMPERATURE
- VISCOSITY SETTING
- COMPRESSOR CYCLE TIME
- COMPRESSOR ON DELAY
- BEATER OFF DELAY
- MIX PUMP OFF DELAY
- WHITESPOT ADJUST
- CAL SYRUP TIME
- DRAW SAFETY TIME
- EDIT UNIT ID
- CALIBRATE PROXIMITY SWITCH
- SELECT LANGUAGE
- ABORT HEAT CYCLE
- SYRUP MOTOR SETUP
- SHAKE DRAW SETUP
- MANUAL CONTROL
- SOFTWARE UPDATE
- RESET TO DEFAULTS

Service Menu Options

1. Press the Auto key  or Flavor Selection key  to move up or down through the Menu.
2. Select a Menu option by aligning the option with the cursor (>) on the left side of the screen.
3. Press the Calibration key .
4. Exit the Menu program by selecting EXIT FROM MENU or touch the CONE key .

The following Menu options are listed in the Service Menu:

Note: Options EXIT FROM MENU through NET SERVICE PIN can also be accessed through the Manager Menu.

- EXIT FROM MENU
- SYRUP CALIBRATION
- VERIFY CALIBRATION
- SERVINGS COUNTER
- SET CLOCK
- AUTO HEAT TIME
- AUTO START TIME
- STANDBY MODE
- BRUSH CLEAN CYCLE
- MIX LEVEL AUDIBLE

EXIT FROM MENU

Selecting EXIT FROM MENU closes the Menu and returns the control panel keys to normal operation.

SYRUP CALIBRATION

The SYRUP CALIBRATION option allows the technician to access the calibration screen selections from the Service menu. The same functions found in the Calibration menu are displayed on the screen when this menu option is selected:



Figure 2-31

Note: The UNFLAVORED DRAW option will only appear on the screen when the shake side is in the Auto mode.

(See “Syrup Calibration” on page 2-80.)

VERIFY CALIBRATION

Use the VERIFY CALIBRATION option to verify that the amount of syrup dispensed is within the proper specification. (See Figure 2-32.)

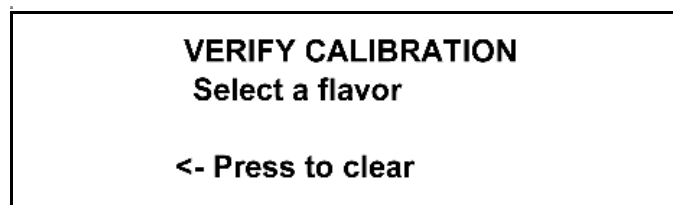

Figure 2-32

To verify the syrup calibration:

1. Remove the syrup valve from the dispensing door.
2. With the line fully primed with syrup, position the syrup valve over the small chamber side of the divided syrup cup.
3. Select the corresponding favor selection. Syrup will flow into the cup for 5 seconds (7 seconds for triple thick shake syrup) and then automatically stop flowing.

4. Place the cup on a flat surface and check the amount of syrup dispensed. If the level is not within the correct specification, the flavor will need to be recalibrated.
5. Select the Calibration key to exit the VERIFY CALIBRATION screen and return to the menu list.

SERVINGS COUNTER

Use the SERVING COUNTER screen to check or reset the number of servings dispensed from the machine. (See Figure 2-33.)

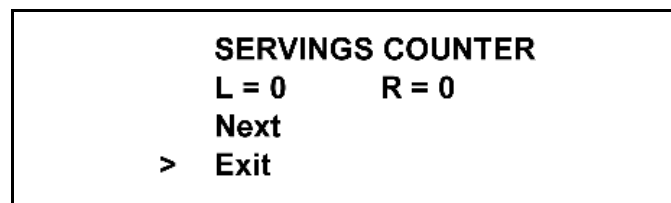

Figure 2-33

To reset the SERVINGS COUNTER:



1. Select the Auto key  to move the cursor (>) to Next. The Reset Counters and Details selections will be displayed on the next screen:



Figure 2-34

2. Select the Auto key  to move the cursor (>) to Reset Counters.
3. Then select the Calibration key . The display will ask, “Are you sure?” (See Figure 2-35.)

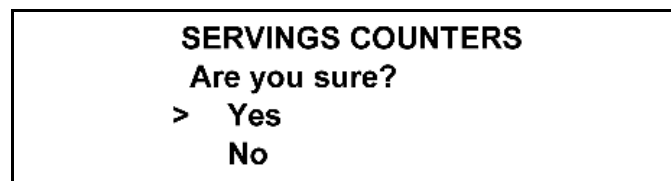





Figure 2-35

4. To reset the counters, select the Auto key  to move the cursor (>) to YES.
5. Select the Calibration key  to clear the left and right counters and return to the SERVINGS COUNTER screen. If you do not want to clear the serving counter, move the cursor (>) to No and select the Calibration key  to return to the SERVINGS COUNTER screen without resetting the counters to zero.

Note: The SERVINGS COUNTER will automatically reset to zero when the machine is brush-cleaned. (See See Figure 2-36.)

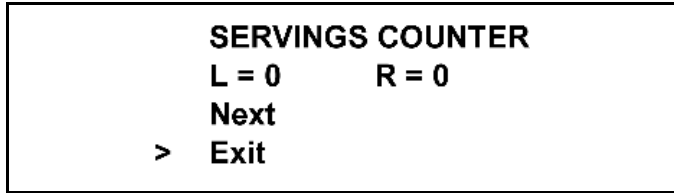



Figure 2-36

To access the details screen:

1. Select Next in the SERVINGS COUNTER screen.
2. Move the cursor (>) to Details, and then select the Calibration key  .. (See Figure 2-37.)

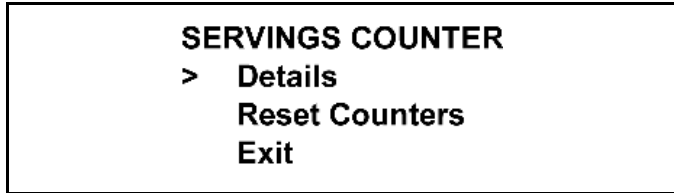

Figure 2-37

The SERVINGS COUNTER menu will display details for the number of servings for each flavor (chocolate, strawberry, vanilla, option, unflavored, and soft serve), and count the method that ended the draw for each flavor (pyroelectric sensor detection, manually selecting a flavor key, draw safety timeout, and other). (See Figure 2-38.)

Example:

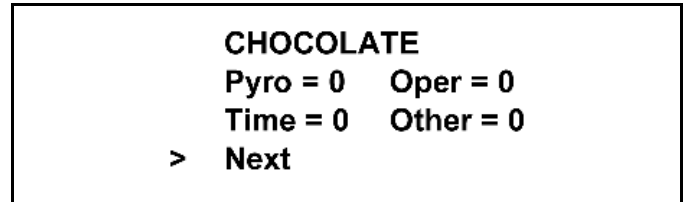

Figure 2-38

Pyro = Pyrosensor detected and triggered the end of the draw.

Time = The draw safety time setting was reached before the pyrosensor detection or before a flavor key was selected.

Oper = A flavor key was selected to terminate the draw.

Other = Any draw termination that is not Pyro, Time, or Oper.

Example: Power switch turned to OFF while product is dispensing.

SET CLOCK

The SET CLOCK screen allows the manager or service technician to adjust the control clock date and time. The date and time may only be changed after the freezer has been manually cleaned but before it has been placed in the Auto or Standby mode. The following message will be displayed if the SET CLOCK option is selected when the machine is not in a brush-clean state. (See Figure 2-39.)

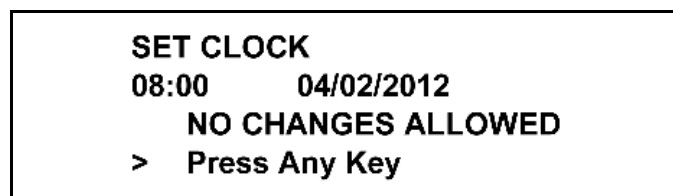



Figure 2-39

Change the date or time:

1. Select the SET CLOCK option in the menu.
2. Touch the Auto key  to advance the cursor (>) from Exit to Change.
3. Press the Calibration key  to select the Change option. (See Figure 2-40.)

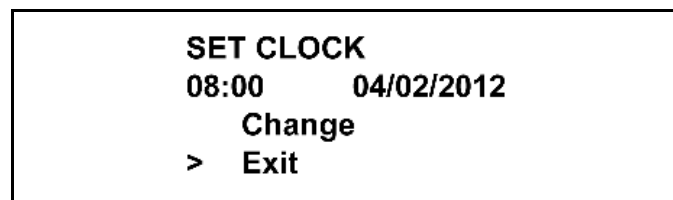





Figure 2-40

4. Change the time by touching the Auto  or Flavor Selection key  with the cursor under the hour position.
5. Move the cursor to minutes by selecting the Calibration key .

6. Once the correct minutes are entered, select the Calibration key  to advance the cursor to the month. (See Figure 2-41.)

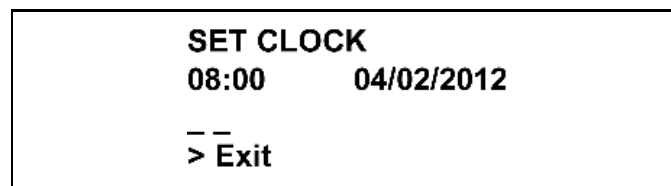



Figure 2-41

7. Enter the correct month, day, and year.
8. Select the Calibration key  to advance to the DAYLIGHT SAVING TIME screen. (See Figure 2-42.)

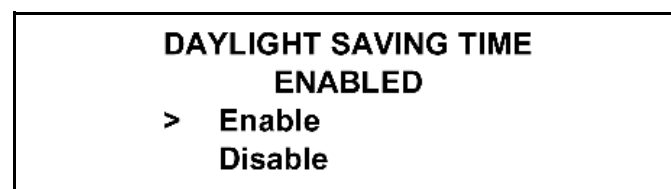





Figure 2-42

Disable the DAYLIGHT SAVING TIME feature:



1. Select the Auto key  to move the cursor (>) to Disable.
 2. Press the Calibration key  to save the selection.
- ### Enable the DAYLIGHT SAVING TIME feature:

1. Select the AUTO key  to move the cursor (>) to Enable.
2. Touch the Calibration key  to save the selection. The DAYLIGHT SAVING TIME feature, when enabled, will automatically adjust the control clock for daylight saving time.

2

CONTROLS

Change the month and week for daylight-saving time:

1. Select the Auto key  to advance the cursor (>) from Exit to Change.
2. Press the Calibration key  to select the Change option and move to the next screen. (See Figure 2-43.)

MAR SECOND SUNDAY
NOV FIRST SUNDAY
Change
> Exit

Figure 2-43

3. Use the cursor (>) keys to scroll to the appropriate month.
4. Press the Calibration key  to accept the selection. (See Figure 2-44.)

DST START MONTH
JAN
FEB
> MAR

Figure 2-44

5. Once the appropriate month has been entered, scroll to the appropriate week. Press the Calibration key  to accept the selection. (See Figure 2-45.)

DST END WEEK
FIRST SUNDAY
> SECOND SUNDAY
THIRD SUNDAY

Figure 2-45

(*Note: Scroll down to see selections FOURTH SUNDAY and LAST SUNDAY.*)

6. Select the month that daylight-saving time will end.
7. Press the Calibration key  to accept the selection. (See Figure 2-46.)

DST END MONTH
JAN
FEB
> MAR

Figure 2-46

8. Select the appropriate week that daylight saving time will end.
9. Press the Calibration key  to accept the selection. (See Figure 2-47.)

DST END WEEK
FIRST SUNDAY
> SECOND SUNDAY
THIRD SUNDAY

Figure 2-47

10. Select the Calibration key  to exit the screen and return to the menu.

AUTO HEAT TIME

The AUTO HEAT TIME screen allows the manager or service technician to set the time of day when the heat treatment cycle will start. (See Figure 2-48.)

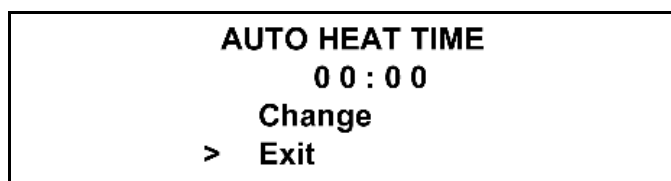



Figure 2-48

Note: Do not advance the AUTO HEAT TIME setting except on the day the machine is brush-cleaned. Increasing the time between heat cycles will cause the machine to soft lock if the start of the cycle does not begin within 24 hours from the start of the previous heat treatment cycle.

To set the AUTO HEAT TIME:

1. Select the Auto key  to move the cursor (>) to Change.
2. Select the Calibration key . The screen will display the time with the cursor under the hour position. (See Figure 2-49.)

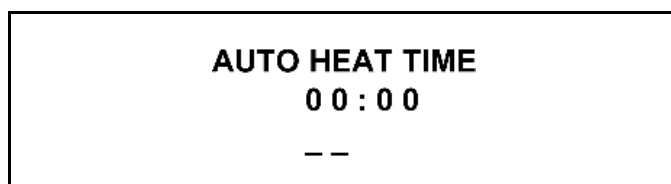







Figure 2-49

3. Select the AUTO key  or the Flavor Selection key  to increase or decrease the hour to the desired setting.
4. Move the cursor to the minutes position by selecting the Calibration key .
5. Adjust the setting for minutes, then select the Calibration key  to save the setting and return to the AUTO HEAT TIME screen.
6. Select the Calibration key  to exit the screen and return to the menu.



AUTO START TIME

The AUTO START TIME screen allows the manager or service technician to set the time of day at which the machine automatically enters the Auto mode from the Standby mode. The machine must be in the Standby mode without a freezer lock condition in order to auto start at the programmable time. The AUTO START TIME can be disabled to start the Auto mode manually. (See Figure 2-50.)



Figure 2-50

To enable the AUTO START TIME:

1. Select the Auto key  to move the cursor (>) up to Enable.
2. Select the Calibration key  to advance to the next screen. (See Figure 2-51.)

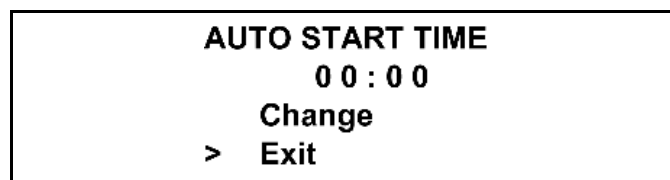



Figure 2-51

3. Program the AUTO START TIME by selecting the Auto key  to move the cursor (>) to Change.
4. Select the Calibration key  to advance to the next screen. (See Figure 2-52.)

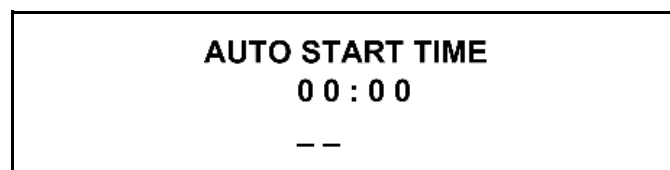







Figure 2-52

5. Program the AUTO START TIME by increasing (Auto key ) or decreasing (Flavor Selection key ) the hour setting above the cursor.



6. Select the Calibration key  to advance the cursor and program the minutes setting.
7. Select the Calibration key  to return to the previous screen with the new time setting displayed.
8. Select the Calibration key  to exit the screen and return to the menu.

2

STANDBY MODE

The Standby option is used only on models which have the control panel Standby keys disabled.

The Standby option is used to manually place the left or right side in the standby mode during long no-draw periods. Select the STANDBY MODE screen from the menu.

1. Select the Auto key  to move the cursor (>) up to the LEFT (shake) or RIGHT (soft serve) side.
2. Select the Calibration key  to activate Standby for the selected side.
3. Repeat the steps to activate Standby mode on the remaining side. (See Figure 2-53.)

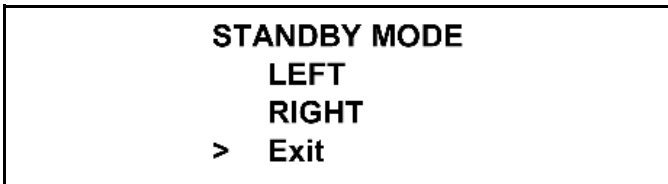

Figure 2-53

4. Discontinue Standby operation for either side by exiting the menu and select the Auto mode.

BRUSH-CLEAN CYCLE

The BRUSH CLEAN CYCLE screen allows the manager or service technician to select the maximum number of days between brush-cleaning the machine. The brush-clean cycle may only be changed after the freezer has been manually cleaned but before it has been placed in the Auto or Standby mode.

The following message is displayed if the BRUSH CLEAN CYCLE option is selected when the machine is not in a brush-clean state:

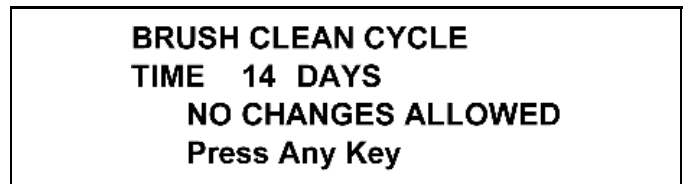





Figure 2-54

To change the number of days between brush-clean intervals:

1. Select the Auto key  to decrease the days or the Flavor Selection key  to increase the number of days.
2. Select the Calibration key  to save the setting and exit back to the Menu.

The number of days displayed on the brush-clean counter will change to the new setting. (See Figure 2-55.)

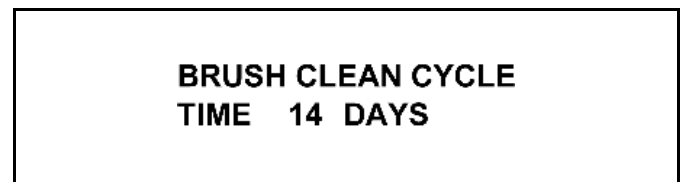

Figure 2-55

Always comply with local guidelines on the number of days allowed between brush-clean cycles.

MIX LEVEL AUDIBLE

The MIX LEVEL AUDIBLE option, when enabled, alerts the operator with an audible tone when there is mix-low or mix-out condition. The following screen is displayed on selecting this option. (See Figure 2-56.)

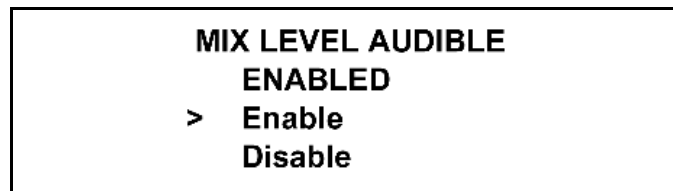

Figure 2-56

To disable the audible tone feature:

1. Select the Flavor Selection key to move the cursor (>) to Disable.
2. Select the Calibration key to save the new setting and return to the Menu. The control panel indicators for Mix Low and Mix Out will illuminate as the mix level drops in the hopper but the audible tone will be disabled.

FAULT DESCRIPTION

The FAULT DESCRIPTION display indicates if there is a fault with the freezer and the side of the freezer where the fault occurred. When no faults are detected the following screen will be displayed. (See Figure 2-57.)



Figure 2-57

Select the Calibration key to display the next fault found or return to the Menu if no other faults exist.

Selecting the Calibration key when faults are displayed clears the faults, if faults were corrected on returning to the menu screen.

Listed below are the various messages which will appear, along with an explanation for the corrective action.

NO FAULT FOUND - There was no fault found in the freezer. Nothing will appear on the screen after this message appears.

BEATER OVERLOAD - Press the beater RESET button firmly for the side of the freezer with the fault.

HPCO COMPRESSOR - Place the power switch in the OFF position. Wait 5 minutes for the machine to cool. Place the power switch in the ON position and restart each side in Auto mode.

HOPPER THERMISTOR BAD - Place the power switch in the OFF position. Replace the bad probe.

BARREL THERMISTOR BAD - Place the power switch in the OFF position. Replace the bad probe.

GLYCOL THERMISTOR BAD - Place the power switch in the OFF position. Replace the bad probe.

PRODUCT DOOR OFF - Place the power switch in the OFF position. Check for proper installation of the dispensing door and that the hand screws are tight.

HOPPER OVER TEMP - Place the power switch in the ON position and verify that the Auto or Standby key is illuminated.

BARREL OVER TEMP - Place the power switch in the ON position and verify that the Auto or Standby key is illuminated.

COMP ON TOO LONG - Compressor runs more than 11 consecutive minutes without the product reaching set point temperature. Check the condenser filter, scraper blades and refrigerant charge. Reprime using fresh mix.

LOCKOUT HISTORY

The LOCKOUT HISTORY screen displays a history of the last 100 soft locks, hard locks, brush-clean dates, or aborted heat treatment cycles. Page numbers are indicated in the upper right hand corner. Page 1 always contains the most recent failure. (See Figure 2-58.)

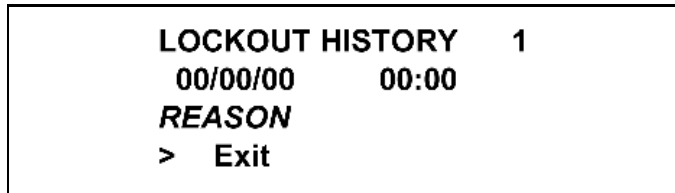



Figure 2-58

The second line of the screen displays the date and time a failure occurs. The third line indicates the reason for a failure, or whether a successful brush-cleaning has occurred. Some failures occur with multiple reasons. When this occurs, a page will be generated for each reason.

Select the Auto key  or Flavor Selection key to scroll forward or backward to view each screen.

Listed below are the various messages that may appear.

Faults Occurring While Entering a Heat Treatment Cycle:

POWER SWITCH OFF - The power switch is OFF.

AUTO OR STBY OFF - The control was not in Auto or Standby mode.

MIX OUT FAILURE - A mix-out condition was present.

NO HEAT CYCLE TRIED - The auto heat time was set to attempt a heat treatment cycle more than 24 hours after the last successful heat treatment cycle.

Faults Occurring While in Heat Mode:

HEAT MODE FAILURE - The maximum allowable heat mode time exceeded 90 minutes.

COOL MODE FAILURE - The maximum allowable cool mode time exceeded 120 minutes.

TOTAL TIME FAILURE - The maximum allowable total heat treatment time exceeded 4 hours.

BRUSH CLEAN TIMEOUT - The total days in operation exceeded the brush-clean cycle setting.

POWER SWITCH OFF - The power switch was turned OFF during the heat treatment cycle.

POWER FAIL IN H/C - A power failure occurred during the heat treatment cycle.

(L/R) MIX LOW FAILURE - The mix level in the (left/right) hopper is too low for a successful heat treatment cycle.

(L/R) BEATER OVLD H/C - The overload tripped for the (left/right) beater motor.

(L/R) BRL THERM FAIL - The thermistor sensor for the (left/right) barrel failed.

(L/R) HOPPER THERM FAIL - The thermistor sensor for the (left/right) hopper failed.

(L/R) HPCO H/C - The (left/right) high pressure switch opened during the heat treatment cycle.

Faults Occurring While in Auto Mode:

(L/R) HPR>41F (5C) AFTER 4 HR - The mix temperature in the left or right hopper was above 41°F (5°C) more than 4 hours.

(L/R) BRL>41F (5C) AFTER 4 HR - The mix temperature in the left or right barrel was above 41°F (5°C) more than 4 hours.

(L/R) HPR>41F (5C) AFTER PF - The mix temperature in the left or right hopper was above 41°F (5°C) more than 4 hours following a power failure.

(L/R) BRL>41F (5C) AFTER PF - The mix temperature in the left or right barrel was above 41°F (5°C) more than 4 hours following a power failure.

(L/R) HPR>45F (7C) AFTER 1 HR - The mix temperature in the left or right hopper was above 45°F (7°C) more than 1 hour.

(L/R) HPR>59F (15C) - The mix temperature in the left or right hopper exceeded 59°F (15°C).

(L/R) BRL>59F (15C) - The mix temperature in the left or right barrel exceeded 59°F (15°C).

FAULT HISTORY

The FAULT HISTORY displays up to 100 faults that have occurred. The most recent fault is displayed on screen 1. The date, time, and fault description is displayed on each screen. (See Figure 2-59.)

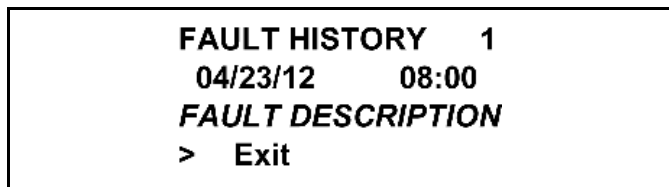





Figure 2-59

To advance to the next most recent occurring fault:

1. Select the Auto key .
2. Scroll the screens in the opposite direction by selecting the Flavor Selection key .
3. Exit the FAULT HISTORY screen and return to the menu by selecting the Calibration key .

Fault Descriptions

(L/R) Comp On Too Long - The left or right main compressor has run for more than 11 consecutive minutes without dispensing product.

(L/R) Product Door Off - The left or right freezer door is not completely installed or the safety interlock circuit has opened.

(L/R) Hopper Therm Bad - The left or right hopper thermistor probe is SHORTED or OPEN.

(L/R) Hopper Over Temp - The left or right hopper thermistor probe is reading over 200°F (93°C).

(L/R) Barrel Over Temp - The left or right barrel thermistor probe is reading over 200°F (93°C).

(L/R) Beater Overload - The left or right RESET mechanism has tripped.

(L/R) HPCO Compressor - The left or right high-pressure switch contacts have opened.

(L/R) Glycol Therm Bad - The left or right glycol thermistor probe is reading over 200°F (93°C).

HEAT CYCLE SUMMARY

The HEAT CYCLE SUMMARY screen displays the hours since the last heat treatment cycle, the hours since the product temperature was above 150°F (65.6°C), and the number of heat cycles completed since the last brush-clean date. (See Figure 2-60.)

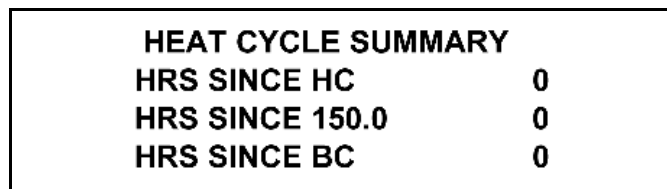



Figure 2-60

HEAT CYCLE DATA

The HEAT TREAT CYCLE DATA screen contains a record of up to 366 heat treatment cycles. The most recent heat treatment cycle data will be shown first. The Standard records have each heat cycle recorded in three screens. Select the Auto key  to move the cursor (>)

to Standard records and select the Calibration key . (See Figure 2-61.)



Figure 2-61

The first screen displays the month and day of the heat treatment cycle, the start and end time, and the fault description. The bottom line displays the record number and indicates if a power failure occurred during the heat treatment cycle (POWER FAILURE IN HC). (See Figure 2-62.)

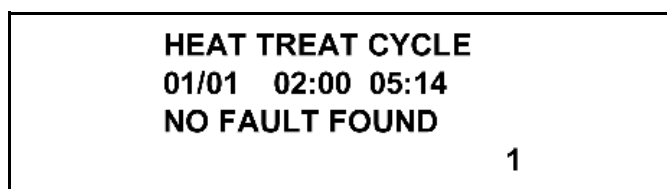



Figure 2-62

CONTROLS

Select the Auto key  to advance through the data pages. Select the Flavor Selection key  to reverse the page direction.

Hopper and barrel temperature records for each side of the freezer are displayed in the second and third screens. The second screen shows the left side (L) of the freezer. (See Figure 2-63.)

H: 40.9	B:26.3	L
HEAT OVER	COOL	PEAK
1:12	0:49	h 1:19
0:46	1.11	b 0:15
		169.7

Figure 2-63

The third screen shows the right side (R) of the freezer. (See Figure 2-64.)

H: 38.0	B:23.7	R
HEAT OVER	COOL	PEAK
1:09	0:52	h 1:11
0:66	1.00	b 0:15
		169.9

Figure 2-64

The top line of these screens shows the hopper (H) and barrel (B) temperatures recorded at the end of the heat treatment cycle and indicates the side (L or R) of the freezer.

The remaining lines indicate the following:



HEAT = Total time for the hopper (H) and barrel (B) to reach 150.9°F (66.1°C).

OVER = Total time the hopper (H) and barrel (B) temperature was above 150°F (65.6°C).

COOL = Total time the hopper (H) and barrel (B) temperature was above 41°F (5°C) during the Cool phase.

PEAK = Highest temperature reading for the hopper (H) and barrel (B) during the heat treatment cycle.

The heat time indicates the amount of time taken in each zone to reach 150.9°F (66.1°C). Each zone must remain above 150°F (65.6°C) for a minimum of 35 minutes. In addition, each zone must be heated for a minimum of 115 minutes.

Select the Auto key  to advance to the next page or the Flavor Selection key  to view the previous page.

A heat treatment cycle failure message will display on the first screen if a failure occurred.

Listed below are various failure code messages which could appear on line 2:

HT	HEAT TIME FAILURE Mix temperature did not rise above 151°F (66.1°C) in less than 90 minutes.
CL	COOL MODE FAILURE Mix temperature in the hopper and freezing cylinder did not fall below 41°F (5°C) in less than 120 minutes.
TT	TOTAL TIME FAILURE The heat treatment cycle must be completed in no more than 4 hours.
MO	MIX OUT FAILURE A mix-out condition was detected at the start or during the heat cycle.
ML	MIX LOW FAILURE The heat phase or cool phase time was exceeded and a mix-low condition was present.
BO	BEATER OLVD IN HC A beater overload occurred during the heat treatment cycle.
HO	HPCO IN HEAT CYCLE A high-pressure cut-out condition occurred during the heat treatment cycle.
PF	POWER FAILURE IN HC A power failure caused the Heat phase, Cool phase, or total cycle time to exceed the maximum allowed time. If a power failure occurs, but the heat treatment cycle does not fail, an asterisk (*) will appear on the third line of the display.
PS	POWER SWITCH OFF The power switch was placed in the OFF position during the heat cycle.
TH	THERMISTOR FAILURE A thermistor probe has failed.
OP	OPERATOR INTERRUPT Indicates the heat treatment cycle was aborted in the OPERATOR INTERRUPT option in the Service Menu.
PD	PRODUCT DOOR OFF A product door is not in place or is loose.

The heat cycle data details record the temperature in the freezing cylinders and mix hoppers every 5 minutes during the heat treatment cycle. Up to 366 heat treatment cycles are recorded. The time and temperature are displayed for the left hopper, left barrel, right hopper, and right barrel for each phase during the heat treat cycle. An individual phase or a complete heat treatment cycle containing all four phases can be viewed.

Heat Treatment Phases

Heat	The phase that heats the mix in the barrels and hoppers to 151°F (6.1°C).
Hold	The phase that maintains the mix temperature above 151°F (6.1°C) for a minimum of 30 consecutive minutes.
Soak	The additional heating time that may follow the HOLD phase to insure the total HEAT, HOLD, and SOAK time is not less than 115 minutes.
Cool	The phase that refrigerates the mix until all four temperature zones are cooled below 41°F (5°C).



In the HEAT CYCLE DATA screen, select the Auto  key to move the cursor (>) up to Details and select the

Calibration key .

HEAT CYCLE DATA	
Standard records	
>	Details
Exit	

The most recent heat treat cycle record (Recd 1) is displayed with the date and time.

To access a different heat treatment cycle record:

1. Select the Flavor Selection key  to move the cursor (>) to Next record.
2. Select the Calibration key . Repeat until the desired record with the date and time is displayed.

Recd 1 03/26 00:00	
>	Display record
Next record	
Exit	

3. With the cursor (>) on the Display record line, select the Calibration key .

HEAT TREAT CYCLE	
>	HEAT phase temps
HOLD phase temps	
SOAK phase temps	

4. Select the Flavor Selection key  to scroll down to the phase to be reviewed. Selecting ALL phase temps displays all four phases of the heat treat cycle record in sequential order.

HEAT TREAT CYCLE	
SOAK phase temps	
COOL phase temps	
>	ALL phase temps

The four temperature readings are recorded at the same time on individual screens.

5. Align the cursor (>) with the phase to be reviewed and select the Calibration key .

HEAT TREAT CYCLE	
>	HEAT phase temps
HOLD phase temps	
SOAK phase temps	

HEAT LH r 1 s 1		
40.0	3/26	02:05
>	Next zone	
Exit		

Table 2-2

Line 1	Displays the Phase	HEAT / HOLD / SOAK / COOL
	LH	Left Hopper
	r 1	Record Number
	s 1	Sample Number
Line 2	Zone Temperature	
	Date and Time Temperature was recorded	

Note: An L or an H displayed to the left of the temperature reading indicates the temperature was the lowest or highest recorded during the phase.

CONTROLS

6. Select the Calibration key to advance the screen to the Next zone. The second temperature zone displayed is the left barrel (LB).

```
HEAT LB r 1 s 1
    25.4 3/26 02:05
> Next zone
Exit
```

If the Cool phase data or All Phase data were reviewed, the final temperature zone sample in the record will be displayed with the selection for the result screen.

```
COOL RB r 14 s 42
    20.0 3/26 05:15
> Result
Exit
```

- 2 7. Select the Calibration key to advance to the next temperature zone, the right hopper (RH).

```
HEAT RH r 1 s 1
    39.5 3/26 02:05
> Next zone
Exit
```

11. Select the Calibration key to view the Heat Cycle results screen.

```
PASS r 1 s 43
Heat Cycle results
> Next record
Exit
```

8. Select the Calibration key to advance to the last temperature zone in the recorded sample, the right barrel (RB).

```
HEAT RB r 1 s 1
    26.5 3/26 02:05
> Next sample
Exit
```

To view the details for the same phase in the preceding record (Next record):

1. Select the Calibration key . If All Phase data was selected, the record number remains the same and the next phase sample is displayed.

```
HOLD LH r 1 s 16
    158.7 3/26 03:15
> Next zone
Exit
```

9. Select the Calibration key again to advance to the next sample. Each sample is displayed in 5-minute increments.

```
HEAT LH r 1 s 2
    46.4 3/26 02:10
> Next zone
Exit
```

2. Exit the record screens by moving the cursor (>) to

Exit and select the Calibration key .

The average heat treatment cycle will contain approximately 40 samples of the four temperature zone screens.

10. When the final sample in the phase is displayed, the Heat Cycle results screen can be selected.

```
HEAT RB r 1 s 14
H 169.0 3/26
> Result
Exit
```

SYSTEM INFORMATION

The SYSTEM INFORMATION is displayed on four separate screens. The first screen contains the control and software version installed in the machine. (See Figure 2-65.)

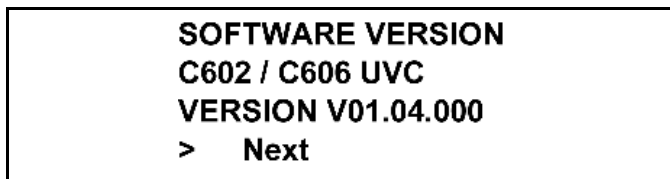

Figure 2-65

Select the Calibration key to advance to the next system information screen containing the software language version. (See Figure 2-66.)

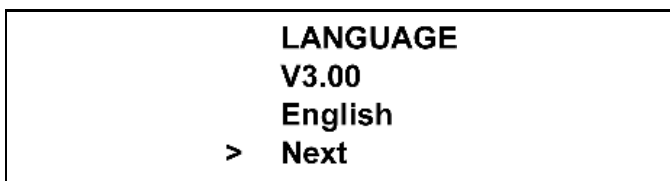

Figure 2-66

For UVC4 models only, select the Calibration key to advance to the third system information screen containing the Boot loader version. (See Figure 2-67.)

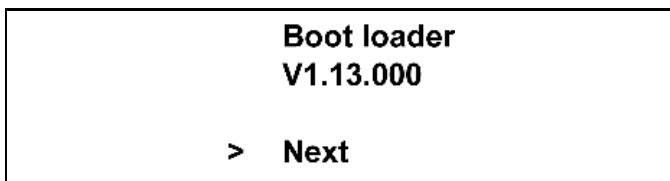

Figure 2-67

Select the Calibration key to advance to the last system information screen containing the model bill of material (B.O.M.) and machine serial number. The model and serial number information must be entered in the EDIT UNIT ID screens in the Service Menu in order to display the machine details in the system information screen. (See Figure 2-68.)

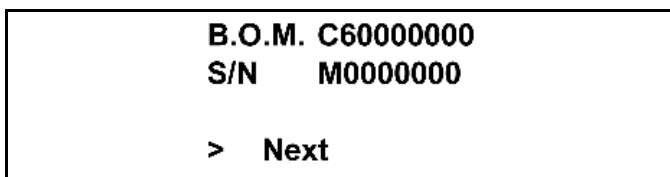

Figure 2-68

Selecting the Calibration key again returns to the menu list.

CURRENT CONDITIONS

The CURRENT CONDITIONS screen provides viscosity readings for the product when the side is running and hopper and barrel temperatures for both sides of the machine. The left column displays the readings for the shake side and the right column displays the soft serve side readings. The bottom line in the display indicates the current glycol temperature.

(See Figure 2-69.)

VISC	0	0.0
HOPPER	38.0	38.0
BARREL	25.0	18.0

Figure 2-69

CURRENT CONDITIONS is the only menu screen that returns the left and right side control panel keys to normal operation. The menu keys are not illuminated when this option is selected so shakes can be dispensed and all panel touch keys are fully functional. Use this screen when you wish to remain in the menu and dispense a shake.

Exit the CURRENT CONDITIONS screen and return to the menu by selecting the Calibration key .

NET SERVICE PIN

The NET SERVICE PIN screen allows the manager to send a LON[®] service message out the power line. This message facilitates the setup of the in-store network with a smart enabled machine. (See Figure 2-70.)



Figure 2-70

To send a LON[®] service message:

1. Press the Calibration key . The following screen appears:

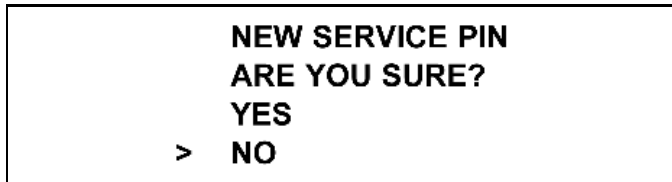



Figure 2-71

2. Press the Auto key  to move the cursor to YES.
3. Press the Calibration key  to select it. The LON[®] service message has now been sent.

Note: All screens from this point forward can only be accessed through the service menu.



TEMPERATURE SCALE

The TEMPERATURE SCALE screen allows the service technician to choose the scale in which the machine will display all temperatures. (See Figure 2-72.)



Figure 2-72

To change the TEMPERATURE SCALE setting:

1. Use the Auto key  or Flavor Selection key  to move the cursor to the desired temperature scale.
2. Press the Calibration key  to save the selection and return to the service menu.

STANDBY TEMPERATURE

The STANDBY TEMP screen allows the service technician to adjust the freezing cylinder temperature in Standby mode. In Standby, the machine cycles the compressor (and beater) on if the temperature of the product in the freezing cylinder rises above the setpoint. The compressor will cycle off when the temperature of the product in the freezing cylinder drops 4°F (2.2°C) or more below the set point. (See Figure 2-73.)

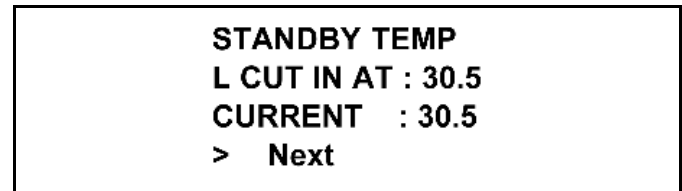





Figure 2-73

To adjust the STANDBY TEMP setting:

1. Use the Auto key  to increase the temperature, or the Flavor Selection key  to decrease the temperature.
2. Save the setting by selecting the Calibration key  to advance to the next screen for the right side freezing cylinder Standby temperature setting. (See Figure 2-74.)

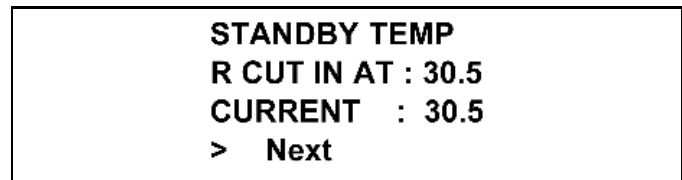



Figure 2-74

3. Select the Calibration key  to save the setting and return to the Service Menu.

HOPPER TEMPERATURE

The HOPPER TEMP screen allows the service technician to adjust the hopper temperature, which is controlled by the glycol pump and the left and right glycol solenoids when the machine is operating in Auto or Standby modes.

Hopper cooling is activated when the mix temperature rises above the set point temperature. When the temperature drops 2°F (1°C) below the set point the hopper cooling is discontinued. (See Figure 2-75.)

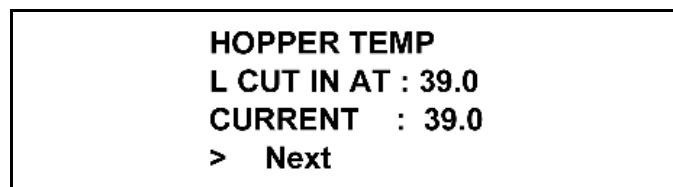



Figure 2-75

To adjust the HOPPER TEMP setting:

1. Use the Auto key  to increase the temperature, or the Flavor Selection key  to decrease the temperature.
2. Save the setting by selecting the Calibration key to advance to the next screen for the right-side hopper temperature setting. (See Figure 2-76.)

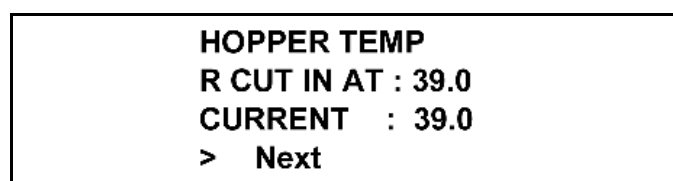



Figure 2-76

3. Select the Calibration key  to save the setting and return to the Service Menu.

GLYCOL TEMPERATURE

The GLYCOL TEMPS screen allows the service technician to adjust the glycol temperature used to control the glycol heater in the Heat and Hold phases of the heat treatment cycle.

When the glycol temperature falls 6°F (3.3°C) or more below the set point, the glycol heater is activated. When the glycol temperature rises above the set point, the heater is deactivated. The factory glycol temperature setting is 178°F (81°C). (See Figure 2-77.)

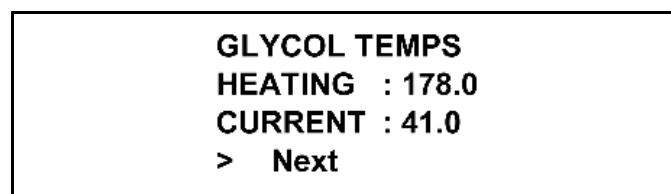



Figure 2-77

To adjust the GLYCOL TEMPS setting:

1. Use the Auto key  to increase the temperature, or the Flavor Selection key  to decrease the temperature.
2. Save the setting by selecting the Calibration key to advance to the next screen for the right Glycol temperature setting in the holding phase. (See Figure 2-78.)

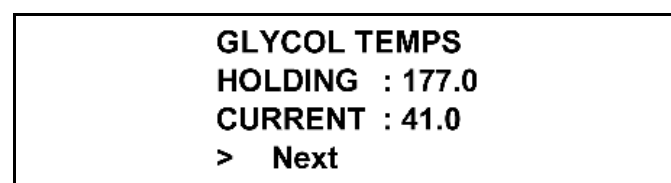





Figure 2-78

The glycol holding temperature set point controls the glycol heater in the holding phase of the heat treatment cycle. When the glycol temperature is 6°F (3.3°C) or more below the set point, the glycol heater is activated. When the glycol temperature rises above the set point, the heater is deactivated. The factory setting for the glycol holding temperature is 177°F (81°C).

To adjust the HOLDING temperature setting:

1. Use the Auto key  to increase the temperature, or the Flavor Selection key  to decrease the temperature.
2. Select the Calibration key  to save the setting and return to the Service Menu.

VISCOSITY SETTING

The VISCOSITY SETTING screen allows the service technician to adjust the viscosity at which the compressor cycles off during the Auto mode of operation.

Select the Auto key  to move the cursor up to the left or right side viscosity setting. (See Figure 2-79.)

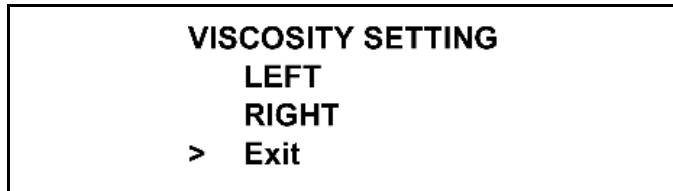



Figure 2-79

Shake Viscosity Setting (Left):

1. Select the Auto key  to increase the viscosity setting.
2. Use the Flavor Selection key  to decrease the setting. (See Figure 2-80.)

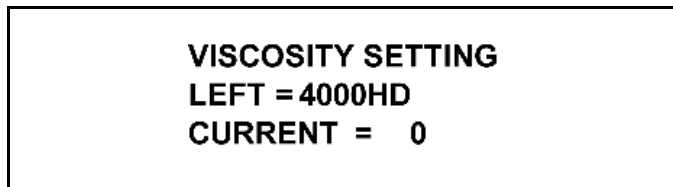





Figure 2-80

Note: A Hedlund (HD) is a Taylor factory defined unit of measure representing the relative product viscosity (thickness). Product in the shake machine is normally set at a viscosity ranging from 4,000 HD to 7,500 HD to accomplish a neutral frozen product temperature around 23°F - 26°F (-5°C to -3.3°C).

Note: While the beater motor is on, the current viscosity indicated on the display is updated continually. When the beater motor is off, this value is zero.

3. Select the Calibration key  to save the setting and return the Service Menu.

Soft Serve Viscosity Setting (Right):

1. From the VISCOSITY SETTING menu screen, use the Auto key  to move the cursor up to the right-side viscosity setting.
2. Select the Calibration key . (See Figure 2-81.)

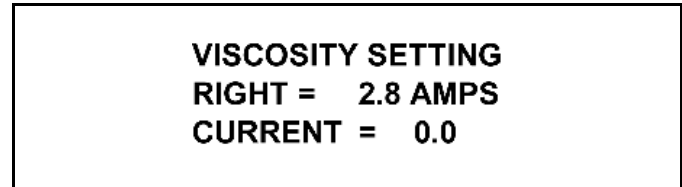





Figure 2-81

3. Select the Auto key  to increase the viscosity setting, or the Flavor Selection key  to decrease the setting.
4. Select the Calibration key  to save the setting and return to the screen to the VISCOSITY SETTING menu.

Soft serve viscosity is measured by monitoring the amperage load of the beater motor. While the beater motor is on, the viscosity or amperage is indicated on the display. When the beater motor is off, this value is zero.

COMPRESSOR CYCLE TIME

The COMP CYCLE TIME screen allows the service technician to set the time that the compressor will cycle on in the Auto mode when product is not dispensed from the machine. Compressor Cycle Times range from 5 min. to 15 min. for shake and soft serve applications and is adjustable in 1-minute intervals.

To adjust the COMP CYCLE TIME:

1. Use the Auto key  or the Flavor Selection key to adjust the setting. The recommended cycle times are 5 minutes for shake and 10 minutes for soft serve.

The left compressor cycle time is displayed first. (See Figure 2-82.)

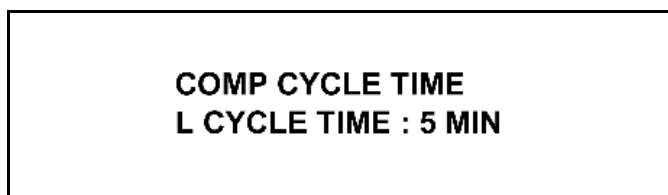

Figure 2-82

2. Advance to the next screen for the right-side setting or return to the service menu by selecting the

Calibration key . (See Figure 2-83.)

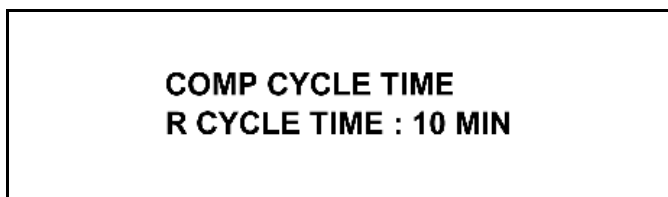



Figure 2-83

COMPRESSOR ON DELAY

The COMP ON DELAY screen allows the service technician to adjust the time the compressor will delay starting when the machine is in the Auto mode. The range for the delay time is 4 sec. to 10 sec. and is adjustable in 1-second intervals.

To adjust the COMP ON DELAY:

1. Use the Auto key  or the Flavor Selection key to adjust the setting.

The left COMP ON DELAY screen is displayed first. (See Figure 2-84.)

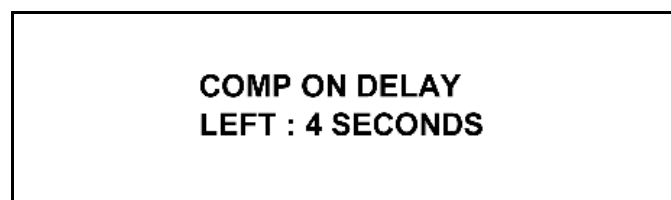

Figure 2-84

2. Advance to the next screen for the right-side setting or return to the service menu by selecting the

Calibration key . (See Figure 2-85.)

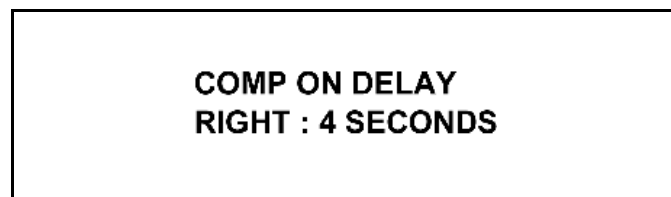



Figure 2-85

2

BEATER OFF DELAY

The BEATER OFF DELAY allows the service technician to set the time the beater motor continues to run after the compressor has cycled off. The range for the delay time is 0 sec. to 10 sec. and is adjustable in 1-second intervals.

To set the BEATER OFF DELAY:

1. Use the Auto key  or the Flavor Selection key  to adjust the setting. The recommended setting is 0 seconds for shake and soft serve applications. The left BEATER OFF DELAY screen is displayed first. (See Figure 2-86.)



**BEATER OFF DELAY
LEFT : 0 SECONDS**

Figure 2-86

2. Advance to the next screen for the right-side setting or return to the service menu by selecting the Calibration key . (See Figure 2-87.)

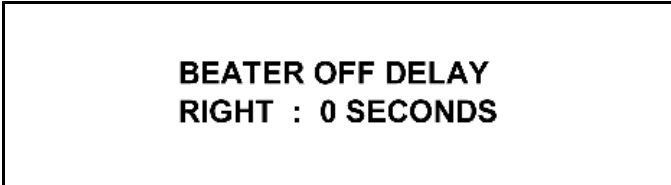

**BEATER OFF DELAY
RIGHT : 0 SECONDS**



Figure 2-87

MIX PUMP OFF DELAY

The MIX PUMP OFF DELAY screen allows the service technician to set the amount of time the mix pump runs after the draw valve has closed (switch open). This adjustment is for the soft serve mix pump only.

The range for the pump off delay is 0 sec. to 30 sec. and is adjustable in 1-second intervals.

To set the MIX PUMP OFF DELAY:

1. Use the Auto key  or the Flavor Selection key  to adjust the setting. The recommended setting is 10 seconds. (See Figure 2-88.)

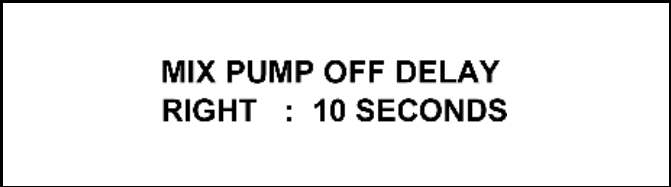

**MIX PUMP OFF DELAY
RIGHT : 10 SECONDS**

Figure 2-88

2. Select the Calibration key  to return to the Service Menu.

WHITESPOT ADJUST

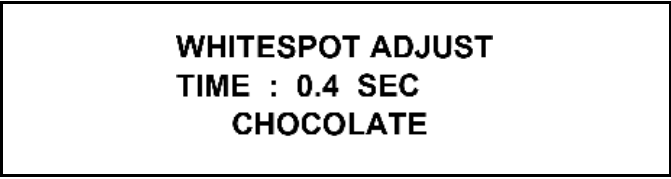

The WHITESPOT ADJUST screen allows the service technician to set the whitespot for each syrup flavor. (See Figure 2-89.)



**WHITESPOT ADJUST
TIME : 0.4 SEC
CHOCOLATE**

Figure 2-89

To change the WHITESPOT ADJUST setting:

1. Select the Auto key  to increase the whitespot setting or the Flavor Selection key  to decrease the setting. The recommended WHITESPOT ADJUST setting for standard shakes is 0.2 seconds. The recommended setting for triple thick shakes is 0.4 seconds.
2. Select the Calibration key  to save the setting and advance to the whitespot setting for the next flavor.

CAL SYRUP TIME

This CAL SYRUP TIME screen allows the service technician to adjust the calibrate syrup time which determines the flow rate of the syrup.

Example: 1 oz. (28 g) syrup dispensed in 5 seconds.

The recommended syrup time for standard shakes is 5 seconds (7 seconds for triple thick shakes).

The following screen is displayed by selecting this option: (See Figure 2-90.)

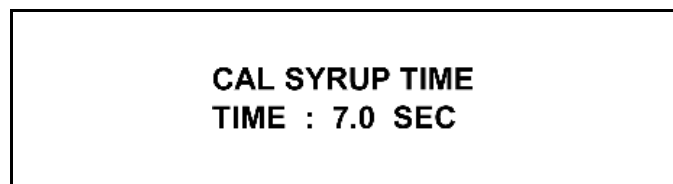





Figure 2-90

To set the CAL SYRUP TIME:

1. Select the Auto key  to increase the time setting or the Flavor Selection key  to decrease the setting.
2. Select the Calibration key  to save the setting and return to the Service Menu.

DRAW SAFETY TIME

The DRAW SAFETY TIME screen allows the service technician to adjust the draw safety time used for closing the shake draw valve in the Auto mode if the fill level is not detected by the portion control sensor. The draw safety time should be set approximately 5 seconds longer than the amount of time it takes to fill the largest serving size.

The following screen is displayed by selecting this option. (See Figure 2-91.)

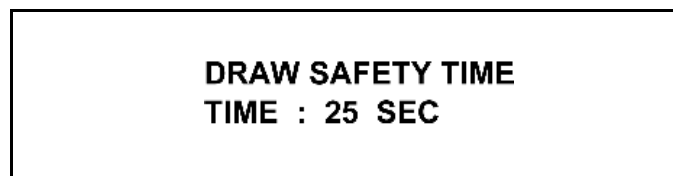





Figure 2-91

To set the DRAW SAFETY TIME:

1. Press the Auto key  to increase the DRAW SAFETY TIME setting or the Flavor Selection key  to decrease the setting.
2. Select the Calibration key  to save the setting and return to the Service Menu.

EDIT MACHINE ID

This option allows the service technician to enter the factory Bill of Material (B.O.M.) code used to assemble the machine, the freezer Serial Number and the Store Identification Number. This information must be programmed in the service menu in order to view the information in the SYSTEM INFORMATION screens. (See Figures 2-92, 2-93 and 2-94.)

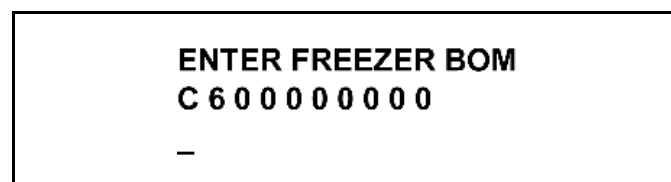





Figure 2-92

To edit the machine ID:

1. Select the Auto key  to increase the value or the Flavor Selection key  to decrease the value.
2. Select the Calibration key  to move the cursor to the right and advance to the serial number screen.

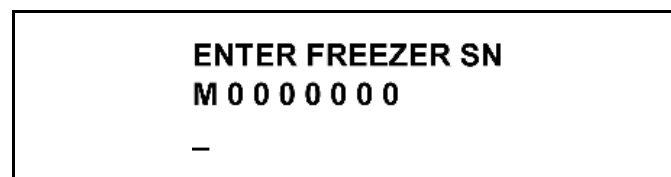

Figure 2-93

3. Enter the serial number from the machine's data label in the same manner as the BOM.

4. Select the Calibration key to save the setting and advance to the store identification screen.



Figure 2-94

5. Enter the store number.
6. Select the Calibration key to save the setting and return to the Service Menu.

2

CALIBRATE PROXIMITY SWITCH

This option allows the service technicians to adjust the mounting of the proximity switch. This procedure must be performed while the machine is fully assembled and properly primed. In addition, the product temperature must be above 32°F (0°C). If the temperature is below 32°F (0°C), the temperature error screen will be displayed. (See Figure 2-95.)

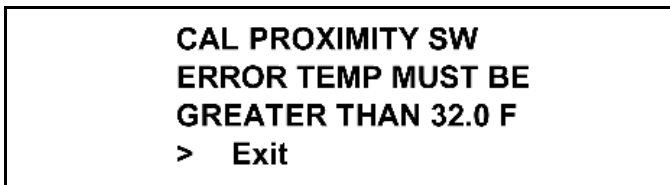

Figure 2-95

When the barrel temperature is above 32°F (0°C), the CAL PROXIMITY SW screen will be displayed and the shake-side beater motor will be activated. (See Figure 2-96.)

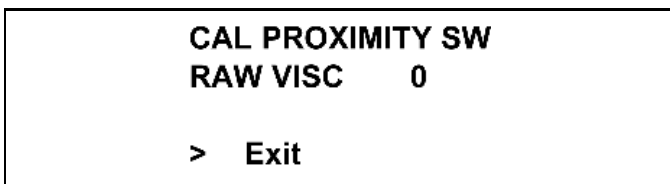

Figure 2-96

To adjust the proximity switch:

1. When the CAL PROXIMITY SW message is displayed, adjust the distance between the proximity probe and the torque coupling to increase or decrease the raw viscosity displayed.
2. When the raw viscosity is between 1,000 to 1,500, an audible tone will sound at regular intervals. The target setting is the middle of the audible tone range.

3. Upon completion of the calibrating procedures, lock the switch down.
4. Verify that the viscosity setting is correct after the switch is locked.
5. Select the Calibration key to return to the Service Menu screen and discontinue beater motor operation.

SELECT LANGUAGE

The SELECT LANGUAGE option allows the service technician to select the language for the fluorescent display. Several language options are available.

Use the Flavor Selection key or Auto key  to move the cursor (>) to the desired language, then touch

the Calibration key to save the selection. (See Figure 2-97.)



Figure 2-97

ABORT HEAT CYCLE

This option allows the service technician to abort a heat treatment cycle. The screen below will be displayed

when selecting this option. Use the Auto key  to move the cursor (>) to YES, and then select the

Calibration key to abort the heat treatment cycle and return to the Service Menu. (See Figure 2-98.)



Figure 2-98

SYRUP MOTOR SETUP

The SYRUP MOTOR SETUP option allows the service technician to adjust the running speed for each syrup pump motor in the Calibration mode and the reverse time for the pump motor.

The SYRUP MOTOR SETUP option also allows the service technician to adjust four programmable timers (delays).

Syrup Pump Motor Adjustment

The proper syrup motor setting should be set to gradually fill the Calibration cup. If the syrup motor setting is too fast, the syrup will fill the cup too fast to accurately stop the flow at the proper level.

The recommended setting for the syrup motor is 50 to 80 for thin shake syrup. For triple thick shake syrup, the syrup motor setting may need to be set higher if the flow rate is too slow. (See Charts A and B.)

The following screen appears when the Syrup Motor Setup option is selected:

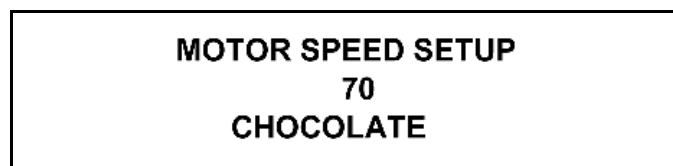





Figure 2-99

To adjust the syrup motor:

Select the Auto key  to increase the syrup motor setting or the Flavor Selection key  to decrease the setting. Select the Calibration key  to advance to the next screen.

Syrup Pump Motor Reverse Time Adjustment

The second screen in the Syrup Motor Setup option allows the service technician to adjust the reverse time for the syrup pump motor. (See Figure 2-100.)

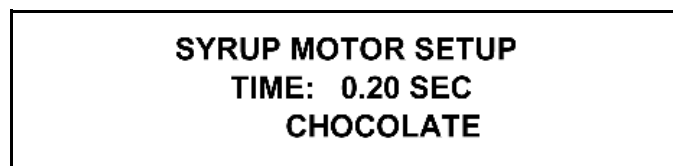

Figure 2-100

Each peristaltic pump motor must reverse the syrup flow momentarily when the flow is stopped in order to eliminate the pressure in the line and close the duckbill syrup valve. The reverse time setting for most thin syrups is 0.25 seconds. Triple thick shake syrup may require a slightly longer reverse time setting. See charts below.

Chart A: Triple Thick Shake Syrup

Table 2-3

Flavor	Motor Speed	Reverse Time
Chocolate	70 to 80	0.28
Strawberry	80 to 100	0.28
Vanilla	60 to 80	0.25
Optional	50 to 80	0.25

Chart B: Thin Shake Syrup



Table 2-4

Flavor	Motor Speed	Reverse Time
Chocolate	50 to 80	0.25
Strawberry	50 to 80	0.25
Vanilla	50 to 80	0.25
Optional	50 to 80	0.25

If the reverse time setting is too short, pressure remaining in the line may cause syrup to seep past the duckbill valve after the shake is dispensed. When this occurs, the flavoring will carry over to the next serving.

If the reverse time setting is too long, an air pocket may form in the syrup line connected to the freezer door. An air pocket in the line will delay syrup blending with the frozen mix causing unflavored product to be dispensed in the bottom of the cup.

To set syrup motor reverse time:

1. Select the Auto key  to increase the reverse time setting or the Flavor Selection key  to decrease the setting.
2. Select the Calibration key  to advance to the motor speed setting screen for the next flavor.

3. Enter the settings for the remaining flavors in the same manner, then select the Calibration key to return to the Service Menu.
4. To save the syrup motor setup settings you must advance through the screens for each flavor by selecting the Calibration key. Exiting the menu option by any other manner will not save the new settings. (See "Syrup Motor Set Up" on page 2-78.)

2 SHAKE DRAW SETUP

Draw Sequence Delay Timers

Four service programmable timers (delays) have been incorporated into the C602 software, beginning with version 1.10. Each timer may be programmed for a delay of 0 sec. to 5 sec. in 0.1 second increments.

The purpose of the delay timers is to adjust the product appearance when clear plastic cups are used. Minor adjustments can be made in the delay time settings to reduce the amount of unflavored shake product that appears at the bottom of the cup.

The default value for each of the draw sequence delay timers is zero, which causes the machine to operate as it has in all previous software versions.

When clear cups are used, the draw sequence can be adjusted as follows:

1. Selecting a flavor key immediately starts the beater motor and activates the BTR-SYR PMP DELAY TIMER. Adjusting the setting allows the beater to stir the partially melted product that may be around the draw valve inside the freezer door. Recommended setting: 0.5 seconds. (See Figure 2-101.)

SHAKE DRAW SETUP
BTR - SYR PMP DELAY
TIME: 0.0 SEC

Figure 2-101

2. After the BTR-SYR PMP DELAY time has elapsed, the syrup pump is activated. The SYR PMP-SPNR DELAY allows time for the syrup pump to achieve dispensing pressure in the syrup line and freezer door before the spinner motor is activated and the draw valve opens. Recommended setting: 0.0 seconds. (See Figure 2-102.)

SHAKE DRAW SETUP
SYR PMP-SPNR DELAY
TIME: 0.0 SEC

Figure 2-102

3. Following the SYR PMP-SPNR DELAY, the spinner motor is activated. The spinner will run prior to the draw valve opening. Recommended setting: 0.3 sec. to 0.4 sec. (See Figure 2-103.)

SHAKE DRAW SETUP
SPNR-DRAW VLV DELAY
TIME: 0.0 SEC

Figure 2-103

4. After the SPNR-DRAW VLV DELAY time has elapsed, the draw solenoid is powered to open the draw valve. The mix pump can be delayed from starting after the draw valve opens by the DRW VLV-MIX PMP DELAY. Recommended setting: 0.0 seconds. (See Figure 2-104.)

SHAKE DRAW SETUP
DRW VLV - MIX PMP DELAY
TIIME: 0.0 SEC

Figure 2-104

5. The last screen in the Shake Draw Setup is the CUP FILL DELAY. The setting range is 0.0 sec. to 3.0 sec., adjustable in increments of 0.5 seconds. The recommended setting is 2.0 seconds. The CUP FILL DELAY is adjusted to prevent the fill sensor from prematurely ending the draw due to product splashing in the cup or by detecting a temperature change when product begins to dispense. (See Figure 2-105.)

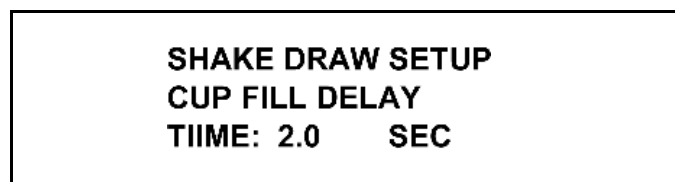

Figure 2-105

MANUAL CONTROL

This option allows the technician to start and stop key components to test their performance. When selected manually, power will be supplied to each component until the technician selects OFF or exits the screen. The technician must manually select OFF or exit the menu.

- > EXIT
- LEFT BEATER MOTOR
- LEFT COMPRESSOR
- LEFT MIX PUMP
- LEFT GLYCOL SOLENOID
- LEFT SYRUP HEATER
- RIGHT BEATER MOTOR
- RIGHT COMPRESSOR
- RIGHT MIX PUMP
- RIGHT GLYCOL SOLENOID
- RIGHT SYRUP HEATER
- GLYCOL PUMP
- GLYCOL HEATER
- SPINNER MOTOR
- AGITATOR MOTOR

The freezer must be off to use this feature. (See Figure 2-106.)

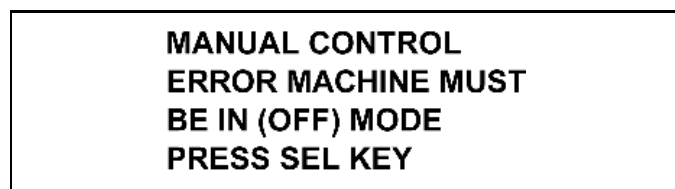

Figure 2-106

Press the SEL key to enter the manual control option. (See Figure 2-107.)

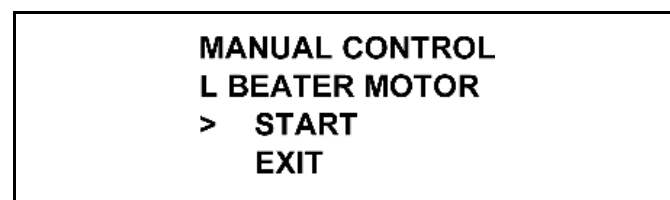

Figure 2-107

Pressing the SEL key with the cursor (>) on START sends voltage to the component selected. (See Figure 2-108.)

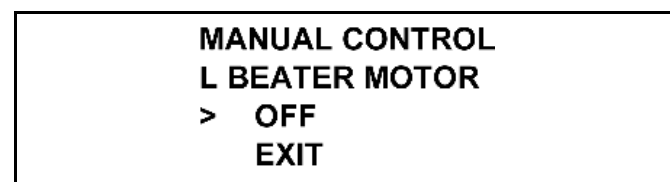

Figure 2-108

Pressing the SEL key with the cursor (>) on OFF turns the component off. Moving the cursor (>) to EXIT turns the component off and exit this menu option.

SOFTWARE UPDATE

UVC4 Models Only: This selection allows the service technician to load new software into the control, using a flash drive on the USB port.

Note: Only factory supplied USB drives may be used to perform the software update. **Do not** make copies of factory supplied USB drives with generic USB drives. Failure to follow this instruction can cause issues in successfully completing the software update.

Selecting the SOFTWARE UPDATE option displays the following screen:

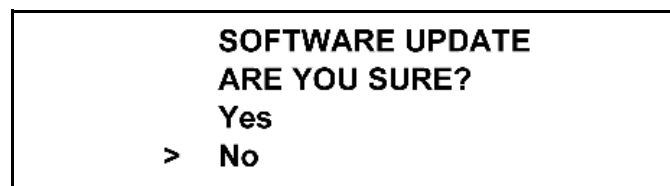



Figure 2-109

Select the Auto key  to move the cursor (>) to Yes

and press the Calibration key . Loading Firmware will be displayed for approximately 20 seconds, followed by Communication Failure for the remainder of the loading process. The heartbeat LED on the UVC4 control will flash at the normal rate during the first portion of the operation and then begin to flash at a slightly faster rate. The entire update process should take about 3 minutes.

2 RESET TO DEFAULTS

The Reset to Defaults option allows the service technician to clear all RAM memory. This screen was added because it will not be possible to remove the RAM chip on future iterations of the UVC3 control. The machine must be in a Unit Cleaned status in order to restore the default settings. Selecting this option in the menu will display a screen asking ARE YOU SURE? (See Figure 2-110)

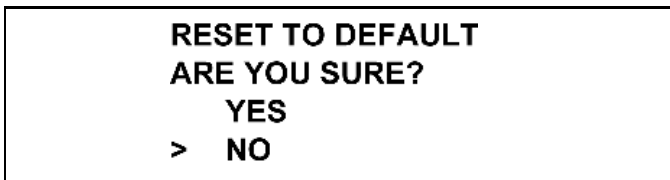

Figure 2-110

Moving the cursor to YES and selecting the Calibration key restores all factory default values.

Heat Treatment

Heat Treatment Cycle

The function of the heat treatment cycle is to raise the temperature of the mix in the freezing cylinder(s) and hopper(s) high enough and quickly enough to destroy bacteria. When this has been accomplished, the temperatures must then be returned to a temperature low enough and quickly enough to retard spoilage.

The heat treatment cycle must be successfully completed at least once every 24 hours or the freezer will automatically lock itself in the Standby mode.

Single freezing cylinder operation is now available. The software keeps track of the freezing cylinder(s) in use. Therefore, the heat treatment cycle can now be performed on only one side, if the other side has not been placed in Auto or Standby mode since the machine was last brush-cleaned.

The heat treatment cycle may be started automatically according to the Auto Heat Cycle Time.

Important! *The freezer must be operating in either the Standby or Auto mode before a heat treatment cycle can be started.*

There are three phases in a heat treatment cycle: Heat, Hold, and Cool.

The Heat Phase

During this phase, the temperatures of the product in the freezing cylinder and hopper are raised to over 151.5°F (66°C) in 90 minutes or less.

The Heat Phase Timer determines the maximum allowable amount of time the machine can remain in the Heat phase of the heat treatment cycle. If the timer exceeds 90 minutes, the machine will lockout.

The Hold Phase

During the Hold phase, the temperature of the product is held over 151.5°F (66°C) for a minimum of 30 minutes to ensure the destruction of all harmful bacteria in the product.

The Hold Phase Timer maintains the Hold phase interval for 30 minutes as long as all freezing cylinder and hopper temperatures remain above 151.5°F (66°C) for the duration of the Hold phase.

The heat soak timer prevents the Hold phase from entering the next Cool phase of the cycle until the 30 minutes is satisfied and until the total time of the Heat and Hold cycles combined is greater than 115 minutes.

The Cool Phase

During the Cool phase, the product in the freezing cylinder and the hopper is lowered to 41°F (5°C) or less. The machine must complete this phase in less than 120 minutes.

The Cool Phase Timer measures the maximum allowable time the machine can remain in the Cool phase. If the timer exceeds 120 minutes, the machine will lockout.

The Heat Cycle TT (Total Time) Timer determines the maximum allowable time the machine can remain in the heat treatment cycle (4 hours). If the timer exceeds 4 hours, the machine will lockout. This timer is a combination of the Heat, Hold, and Cool phase times.

When the entire heat treatment cycle has been completed, the normal display will appear, indicating that the machine is operating in the Standby mode.

Heat Treatment Graph

During the Heat and Hold phases, the glycol is heated by a glycol heater. During the Cool phase, the glycol and freezing cylinder products are refrigerated by the machine's main refrigeration system.

At the start of the Heat phase the glycol heater begins to overcome the cold freezing cylinder temperature and the glycol temperature raises slowly to 178°F (81°C).

The purpose of the Heat phase is to raise the product temperature above 150°F (65°C) within 90 minutes. To satisfy the control system, the product must actually reach 151.5°F (66°C). This requirement ensures that the 150°F (65°C) requirement has been met. Health laws require these parameters to be 150°F (65°C) in 90 minutes; however, the actual amount of time the freezer takes to accomplish this requirement is closer to 60 minutes.

Once the Heat phase is complete, it is necessary to hold the temperature over 150°F (65°C) for a minimum of 30 minutes. From the time the Heat phase is started, 115 minutes must transpire before the Cool phase may enter. Due to the implementation of the Heat Soak Timer, the heat cycle data screen will now refer to the Hold phase as the Over phase.

While in the Cool phase, the beater motor and the main refrigeration system operate continuously until the machine first cycles off. For the remainder of the Cool phase, the beater motor and compressor operate from a timed cycle. The timed cycle allows the beater motor to stop for 2 minutes and then run for 6 seconds. During the 6 seconds that the beater motor is on, if the viscosity is below set point, the compressor is turned on. When viscosity is satisfied, the compressor and the beater are turned off. The timed cycle continues in this manner until the Cool phase is complete.

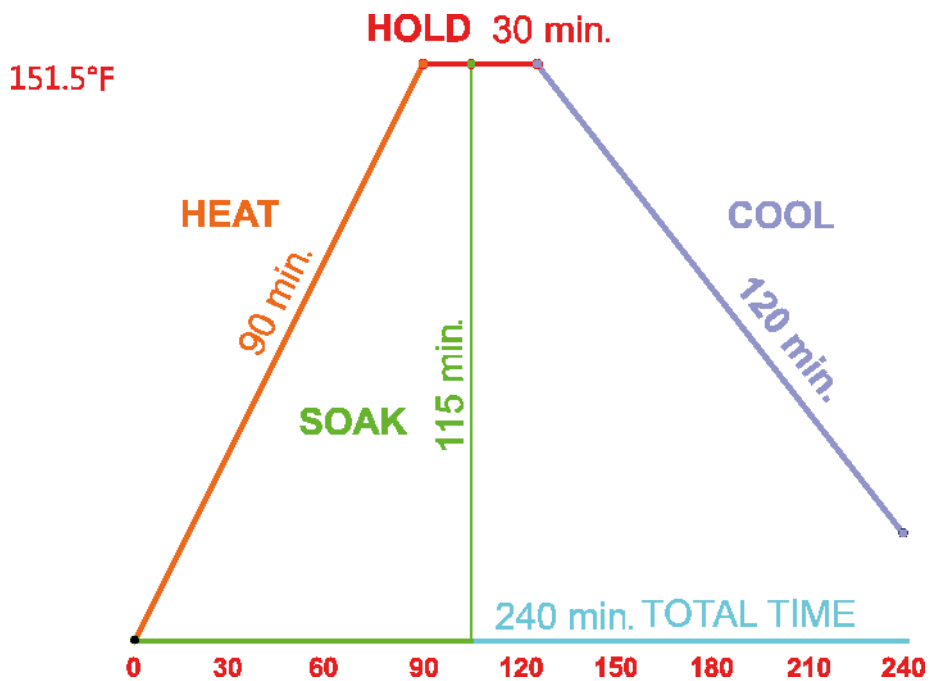

Figure 2-111

2

Timers

2-Minute Stir Cycle

If either side of the machine is in the Standby mode, the beater motor for that side will turn on for 6 seconds every 2 minutes.

If any hopper is above the cut-in temperature, the beater stir cycle timer is activated.

Soft Serve—If the machine is in the Heat mode, this 2-minute stir cycle will continue until the freezing cylinder temperature rises above 135°F (57°C). If the machine is in the Auto mode or the Cool phase of the heat treatment cycle, and the hopper is calling for refrigeration, the beater motor and compressor will continue to run until the viscosity set point has been reached.

Shake—If the machine is in the Auto mode and the hopper is calling for refrigeration, the beater motor will run once every 2 minutes. If the freezing cylinder product viscosity has been satisfied during this beater run time, the beater motor will turn off. Otherwise, the compressor will also turn on and run until the freezing cylinder product viscosity has been satisfied. During the heat treatment cycle the beater motor runs continuously until viscosity is satisfied in the Cool phase, after which the beater motor will run as in the Auto mode to cool the hopper.

Glycol Pump Timer

If either side of the machine is operating in Auto mode, and the hopper requires refrigeration, the glycol pump will operate 1 minute, discontinue for 2 minutes, then operate again for 1 minute. This pattern continues until hopper refrigeration is no longer required.

Mix Pump Timer

Shake—The mix pump will run for 10 seconds anytime the machine is placed in the Auto mode, but not from Standby.

Soft Serve—The mix pump will run for 30 seconds anytime the machine is placed in the Auto mode.

Mix Draw Timer

(Soft Serve Application Only)

During the Auto mode, the mix pump will run for 5 sec. to 30 sec. every time product is drawn from the machine. The factory setting is 10 seconds.

Draw Safety Timer

(Shake Application Only)

During the Auto mode, if the pyroelectric sensor has not detected the product level, the safety timer will terminate the draw. The draw safety timer is adjustable from 3 sec. to 60 sec. The recommended setting is 5 seconds longer than the time required to dispense the largest serving size. International = 11 seconds, triple thick shake = 24 seconds.

Brush-Clean Countdown

The BRUSH CLEAN ON screen shows the number of days before the next brush-cleaning is required. When the display has counted down to 1, the following message will appear on the display. The machine must be disassembled and brush-cleaned within 24 hours:



BRUSH CLEAN ON MM/DD

Figure 2-112

24-Hour Last Heat Cycle Event

If the machine runs longer than 24 hours without a successful heat treatment cycle, the machine will soft lock.

28-Day Timer

If the machine runs longer than 28 days without a successful brush-cleaning, the machine will hard lock.

Note: *This timer is adjustable from 2 days to 28 days.*

Heat Phase Timer

The Heat Phase Timer times out the maximum allowable time the machine can be in the Heat phase of the heat treatment cycle (90 minutes). If the timer exceeds 90 minutes, the machine will lockout.

Hold Phase Timer

This timer assures that product in the freezing cylinder and the hopper is held above 150°F (60°C) for a minimum of 30 continuous minutes.

2

Heat Soak Timer

The Heat Soak Timer prevents the Hold phase from entering the Cool phase until the Hold phase requirements are met and the total time of the Heat and Hold phases is greater than 115 minutes.

Cool Phase Timer

The Cool Phase Timer determines the maximum allowable time the machine can remain in the Cool phase of the heat treatment cycle (120 minutes). If the timer exceeds 120 minutes, the machine will lockout.

Safety Timeout

Once power is applied to the machine, a 60-second timer places the machine in Standby. The tone is turned on in 0.5-second intervals, and a SAFETY TIMEOUT message appears on the display. This timer can be aborted by pressing any key.

Brush-Clean Timer

A 5-minute timer begins when all conditions for a successful brush-cleaning are met:

1. Mix-low or mix-out condition.
2. Hopper and freezing cylinder temperatures are above 60°F (15.6°C).
3. Both freezer doors were removed concurrently.

Glycol

Glycol System

The following information describes the glycol system. For further understanding, see the Glycol Path diagram at the end of this chapter.

The glycol system serves two purposes. During the Standby and Auto modes, the glycol is used to cool the mix hoppers. During the Heat mode, the glycol heats the mix in the hopper(s) and freezing cylinder(s).

Glycol is a heat transfer medium made up of 50% ethylene glycol and 50% distilled water.

Note: *It is factory recommended to drain, flush, and re-supply a fresh glycol mixture on a two-year maintenance schedule.*

Standby and Auto

During a refrigeration cycle, the freezing cylinders are cooled using refrigerant, and the product is controlled by viscosity during the Auto mode and by temperature during the Standby mode.

The hoppers are cooled in the following manner:

When a hopper temperature reaches the cut-in point, the glycol pump, solenoid valve, and beater stir cycle are all activated.

The glycol lines go (in order) through the heater, through the solenoid valve, around the freezing cylinder, and then to the hopper. In other words, the glycol is cooled directly by the freezing cylinder walls and is then pumped to the hoppers to cool the mix. Each hopper has one thermistor probe and can function independently.

Note: *The heater is off during refrigeration modes.*

In each hopper, there is an agitator paddle which is used to distribute the heat or cold evenly throughout the mix so the mix does not freeze or burn on the sides of the hopper. It runs continuously when the freezer is in the Auto, Standby, or Heat mode. The agitator is driven by a motor and belt(s).

The Heat Treatment Cycle

During the heating phase the heater is activated. For shake application, beater agitation will continue until the compressor cycles off. For soft serve application, the beater will agitate for 6 seconds every 2 minutes until the freezing cylinder product rises above 135°F (57°C).

During the Heat phase, all refrigeration is canceled, and the glycol heats the freezing cylinder(s) and the hopper(s) to the set temperatures.



WARNING! Hazardous Liquid.

Ethylene glycol is very harmful to your health. If ingested, contact the local poison control center. Refer to M.S.D.S. Guidelines.

Note: *If the glycol is purchased from the factory, it is pre-mixed and ready to use. Otherwise, glycol should be mixed with distilled water in a ratio of 50% glycol and 50% distilled water.*

Installing the Glycol Mixture

1. Attach a hose (capable of depressing the Schrader valve) to the 1/4 in. flare fitting located beneath the accumulator tank. Remove the cap from the accumulator and place the opposite end of the hose into the accumulator tank.
2. Using a pair of pliers, squeeze the tube located between the access fitting and the tube that leads to the bottom of the glycol accumulator tank.
3. Fill the accumulator tank 2/3 full.
4. Remove the necessary panels to expose the shake interface board. Locate the test pins marked W2, W3, W4, and W5. Place a two pin jumper on the test pins marked W4. The jumper will activate the glycol pump and open the glycol solenoids (if applicable). The glycol existing in the accumulator will be pumped through the glycol system.

5. Monitor the level of glycol mixture in the tank and to be sure all air pockets are removed. Continue to add more as necessary to maintain a 2/3 full level. Allow the machine to operate for a short period of time. Once the service hose starts to empty glycol back into the accumulator tank, the system is properly filled. Remove the jumper from the pins marked W4. Release the pliers.
6. Remove the service hose and replace the cap on the 1/4 in. flare fitting. Replace the accumulator tank cap.
7. Check for glycol mixture leaks.

2

Replenishing the Glycol Mixture

Note: If the accumulator tank is empty, follow the steps outlined in "Installing the Glycol Mixture." (See "Installing the Glycol Mixture" on page 2-43.) If the machine needs replenishing, complete the following steps:

1. Remove the cap from the glycol accumulator tank.
2. Replenish the glycol mixture until the tank is 2/3 full.
3. Replace the cap on the accumulator.
4. Check for glycol mixture leaks.

Draining the Glycol Mixture

1. Attach a service hose (capable of depressing the Schrader valve) to the 1/4 in. access fitting. Allow the opposite end of the hose to rest in an empty bucket.
2. Using a pair of pliers, squeeze the tube located between the access fitting and the tube leading to the bottom of the glycol accumulator tank.
3. Remove the cap from the top of the accumulator tank. The glycol will begin to flow into the bucket.
4. Remove the necessary panels to expose the shake interface board. Locate the test pins marked W2, W3, W4, and W5. Place a two-pin jumper on the test pins marked W4.
5. Once the glycol mixture stops flowing into the bucket, replace the cap on the glycol accumulator tank.
6. Disconnect the outlet line from the glycol pump. Blow air or nitrogen through the outlet line from the glycol pump. This procedure will fully drain the system.
7. Replace the glycol filter.
8. Once the system is fully drained, remove the service hose and replace the access cap. Replace the outlet line of the glycol pump to proper position. Remove the pliers.

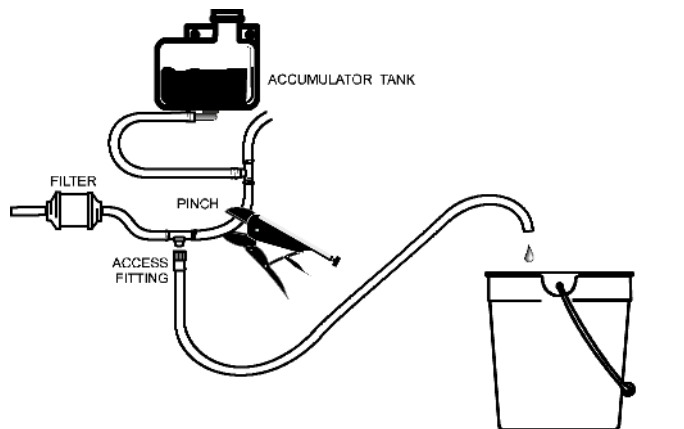

Figure 2-113

Glycol Path

(Rear View)

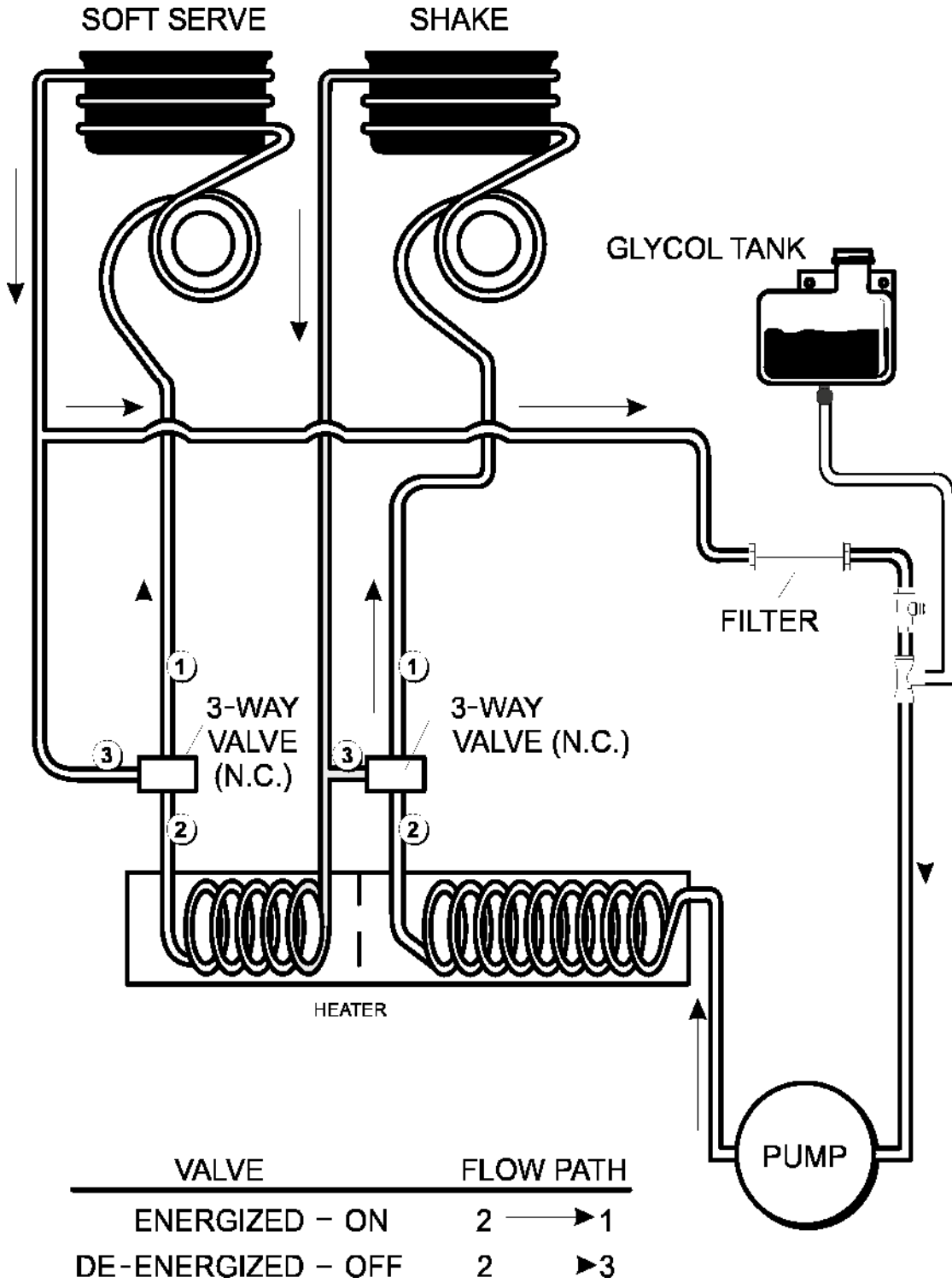

Figure 2-114

2

Setting Viscosity

Viscosity

Viscosity is the term used when referring to product appearance, temperature, thickness, and firmness.

(See "VISCOSITY SETTING" on page 2-30.)

Shake

2 The shake viscosity is measured by monitoring the gap opening of the beater drive coupling which is mounted on the output shaft of the gear machine. The gear machine turns the spring-loaded drive coupling. As the product in the freezing cylinder becomes thicker, the springs collapse, and the size of the gaps change.

As the gaps narrow, the Hedlunds (HD) increase. As the product thickens (becomes colder) the HD increase. After achieving a pre-adjusted HD setting, the refrigeration cycle discontinues.

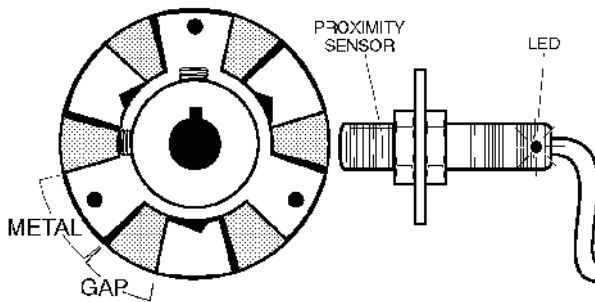

Figure 2-115

The factory default setting for cycle off viscosity is 4,000 HD. To adjust the serving viscosity, it may be necessary to raise or lower the HD setting. Adjust in increments of 100 HDs.

Note: *Be sure that the syrups are correctly calibrated before determining the proper serving viscosity.*

For standard machines, the serving temperature of a flavored shake may range from 24°F to 26°F (-4.4°C to -3.3°C).

For triple thick shake machines, the serving temperature may range from 22°F to 24°F (-5.6°C to -4.4°C).

Soft Serve

The soft serve viscosity is measured by monitoring the amperage load of the beater motor. The amperage load of the beater motor is low when the product in the freezing cylinder is liquid. As the product freezes (thickens), the amperage load increases. When the amperage load reaches the set point, the refrigeration cycle discontinues.

The factory default setting (set point) for soft serve viscosity is 2.8A. The amperage measurement is determined by monitoring the L1 leg of power being delivered to the beater motor. To adjust the serving viscosity, it may be necessary to raise or lower the amperage set point. Adjust in increments of 0.1A.

The serving temperature of soft serve product may vary throughout the day. The serving temperature may range from 16°F to 19°F (-8.8°C to -7.2°C).

Portion Control (Shake)

The portion control sensor, located in the cup bracket, is a pyro-electric sensor which responds to temperature changes. When the draw valve is opened (during the Auto mode) and the product level in the cup reaches the sensor, it will recognize a temperature change. The control board then automatically closes the draw valve.

Portion Control Operation

The interface board receives 16VAC from the transformer and converts it to 12VDC for the personality board.

Auto Mode

If the sensor does not detect the product filling the cup, the control board will automatically close the draw valve after the draw safety time has elapsed.

(See "DRAW SAFETY TIME" on page 2-33.)

Heat Mode

During the Heat mode, the flavor keys will not open the draw valve.

Portion Control Troubleshooting

At Personality Board:

1. Verify that the shake personality board is properly connected to the interface board.
2. Verify J3 (RED header) connections:
 - Pin 3 = WHITE:** The cup-full signal that goes to the UVC through the interface board. It is normally less than 0.2VDC when a cup-full is not sensed, and makes a momentary 5VDC pulse when a cup-full is sensed.
 - Pin 2 = BLACK:** DC ground connection.
 - Pin 4 = RED:** The 12VDC power supply from the interface board.

At Pyro Sensor Board:

1. Verify that the shake personality board is properly connected to the J3 (Red header):
 - Pin 1 - WHITE:** Sense output of the sensor.
 - Pin 2 - BLACK:** DC ground connection.
 - Pin 3 = GREEN:** The 2.5VDC reference output of the sensor.
 - Pin 4 = RED:** The 12VDC power supply for the sensor.
2. Verify that the wiring harness is properly connected on J2:
 - Pin 1 = 12VDC**
 - Pin 2 = Cup-full signal.** It is normally less than 0.2VDC when a cup-full is not sensed, and makes a momentary 5VDC pulse when a cup-full is sensed.
 - Pin 5 = Ground**

Adjustable Draw Handle

This machine features an adjustable draw handle to provide the best portion control, giving a better, consistent quality to your product and controlling costs. The draw handle should be adjusted to provide a flow rate of 5 oz. to 7-1/2 oz. (142 g to 213 g) of product by weight per 10 seconds. To increase the flow rate, tighten the screw. To decrease the flow rate, loosen the screw. After setting the flow rate, tighten the jam nut to secure the adjustment screw.

2

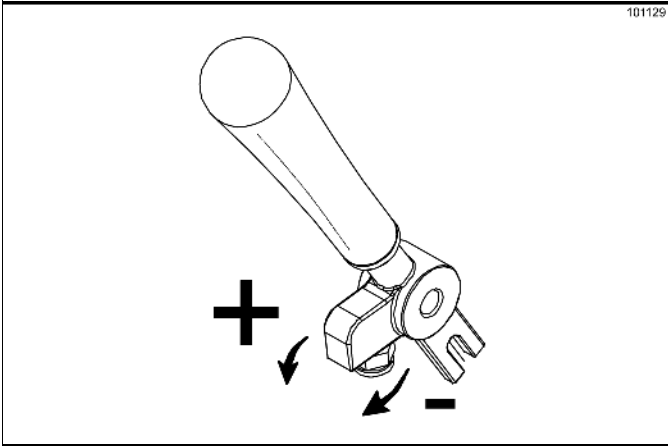

Figure 2-116

Universal Control Overview

Control Overview - UVC3

2

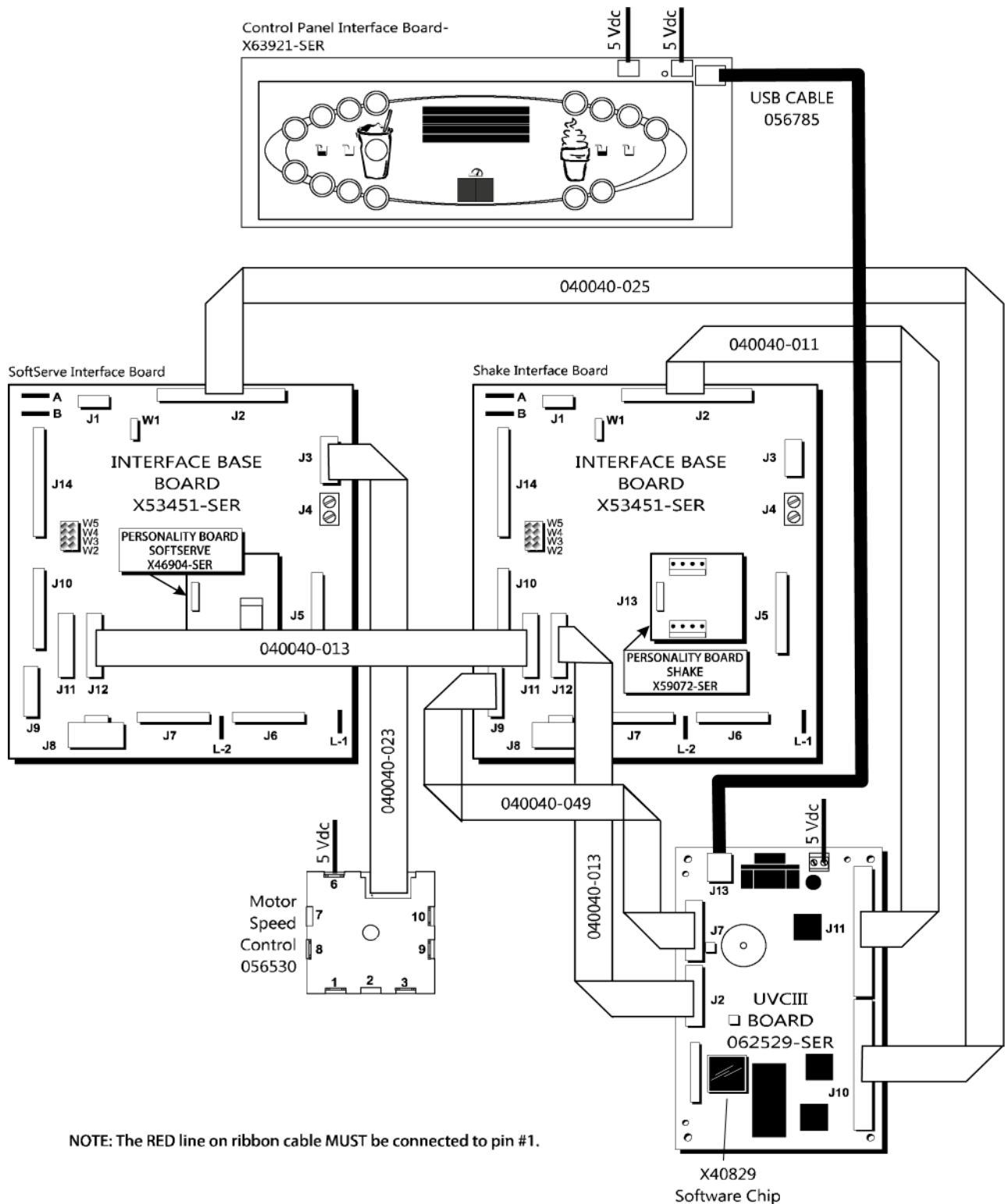

Figure 2-117

Control Overview - UVC4

2

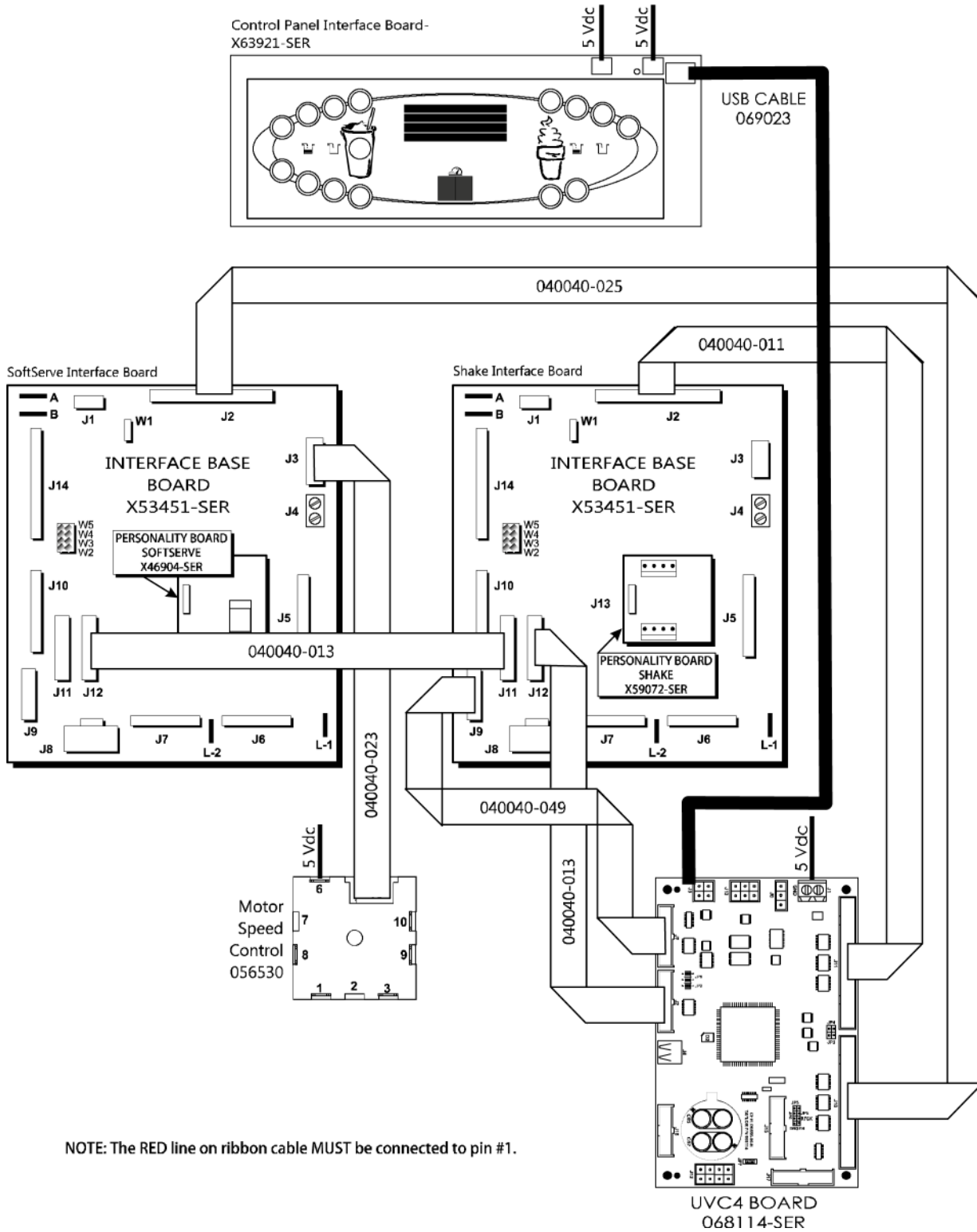

Figure 2-118

Universal Control Board Connection - UVC3

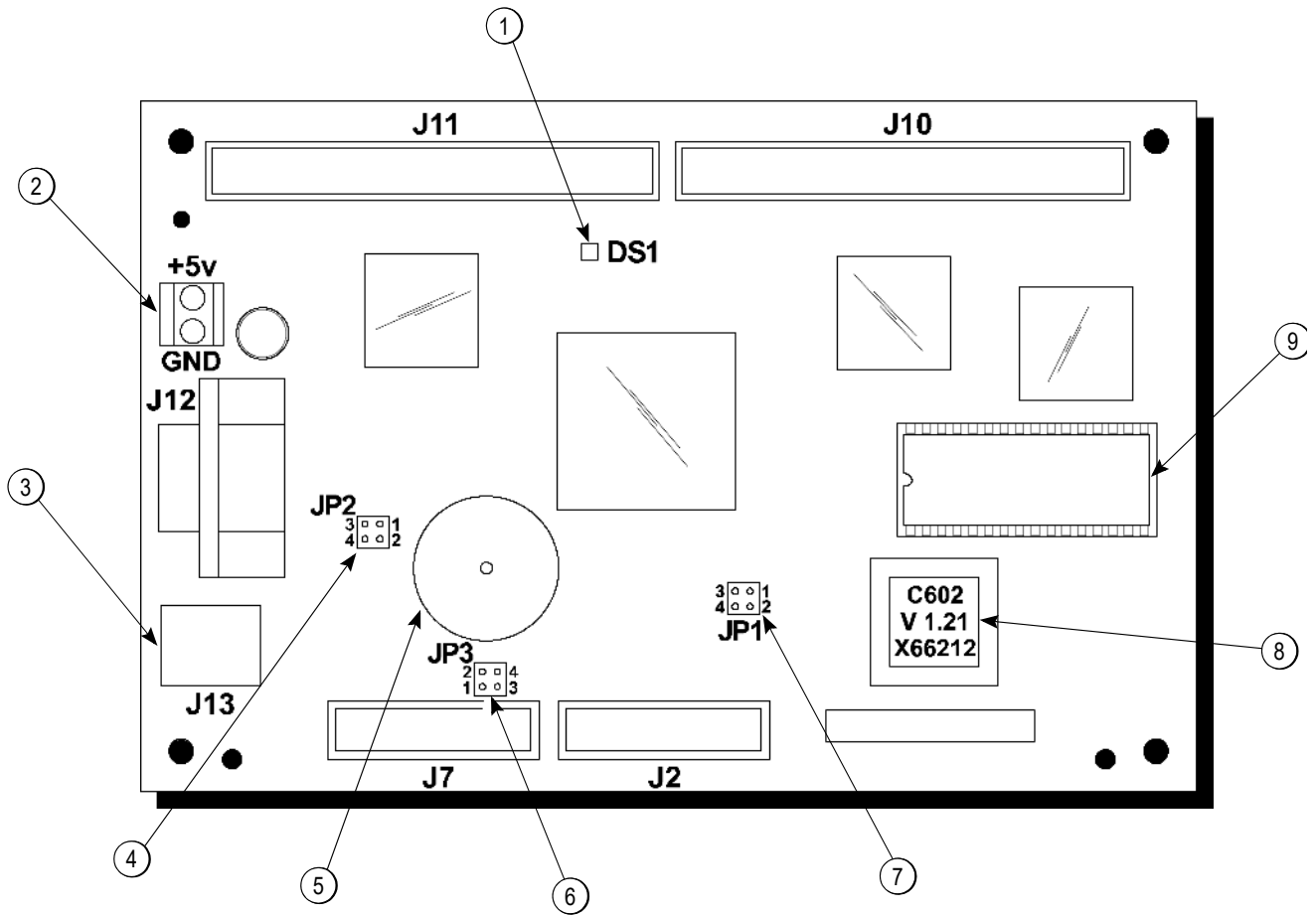

Figure 2-119

Table 2-5

Item	Description	Function
1	LED	When board is powered, LED flashes on (0.5 sec.) and off (0.5 sec.).
2	5VDC Power Supply	Supplies power to UVC3 Board (Range: 4.75VDC - 5.25VDC).
3	USB Cable Connection	Communication to Control Panel Interface Board.
4	JP2 Pins	See Table on page 2-56.
5	Audible Tone Device	Not activated on Model C602. (See Table on page 2-56.)
6	JP3 Pins	See Table on page 2-56.
7	JP1 Pins	See Table on page 2-56.
8	EPROM Chip	PLCC Chip-C602 Software Version Number.
9	RAM Chip	Stores program settings from menu in memory.

Universal Control Board Connections - UVC4

Beginning in January 2011, Taylor started transitioning from the UVC3 to the UVC4.

Note: UVC4 can only be used to replaced UVC3 boards. UVC4 is not compatible with UVC1 or UVC2.

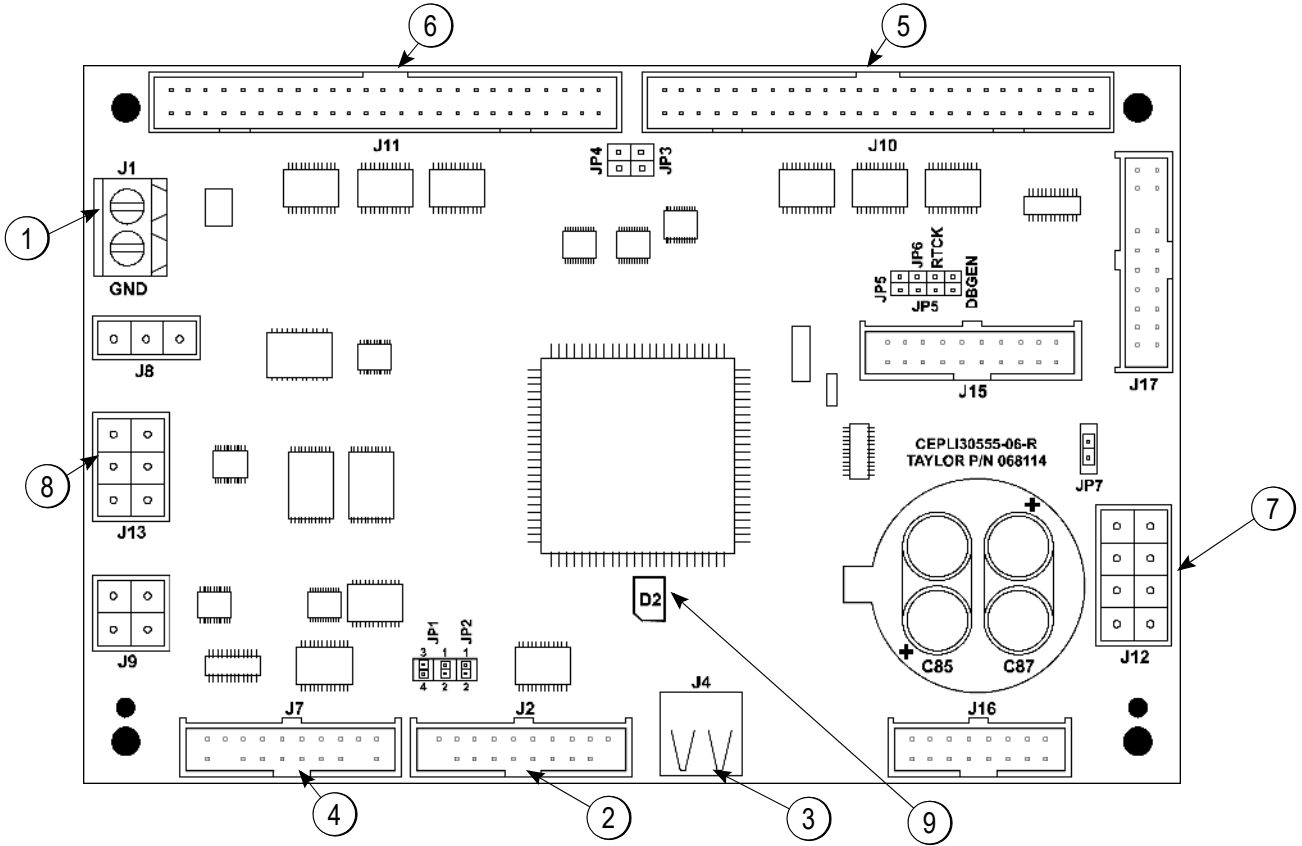

Figure 2-120

The following chart identifies the connections on the board:

Table 2-6

Item	Jumper No.	Function
1	J1	5VDC power input
2	J2	18 pin amp draw and thermistor probe data analog cable
3	J4	USB program port
4	J7	18 pin power loss analog cable
5	J10	50 pin digital cable - left side

Item	Jumper No.	Function
6	J11	50 pin digital cable-right side
7	J12	Local On-site Network (LON) cable
8	J13	User interface cable
9	D2	Heartbeat LED

Important! (See "UVC4 Electrostatic Discharge and Proper Handling Procedures" on page 2-53.)

Universal Control

The universal control is the command center for the machine. The software program for the UVC3 control, including multiple language selections, resides in the EPROM chip. The EPROM chip is not used on the UVC4 universal control.

The settings in the menus are saved in the RAM chip. Removing and reinstalling the software chip will restore the factory default settings in the menus. The RAM chip must be inserted with the notch towards the side of the socket with the notch.

Power is supplied to the 5VDC terminal on the UVC3/UVC4 board from the interface board. The operating voltage range for the control is 4.75VDC to 5.25VDC.

Note: *Beginning with software version 1.07, the default settings can be restored in the Service Menu. This can only be done when the machine is in a Unit Cleaned state. The machine must be cleaned or the W-2 on the shake side interface board must be jumped out to enter a Unit Cleaned state. (See "RESET TO DEFAULTS" on page 2-38.)*

Note: *For installations with low voltage supply (210V or less) it may be necessary to wire the 16VAC transformer on the low voltage tap. Low voltage supplied to the interface board, in turn reduces the voltage supplied to the UVC3/UVC4 board and may cause intermittent power failure tripping or the control panel keys to not function when the machine is powered.*

The UVC3/UVC4 communicates with the control panel interface board through a USB Cable.

There are three sets of pins on the UVC3 board and four sets of pins on the UVC4 board. Refer to the following chart to identify their function.

Note: *Use Part No. 040084-001 Connector-Programming Shunt to jumper pins.*

UVC4 Electrostatic Discharge and Proper Handling Procedures

The UVC4 board is more susceptible to electrostatic discharge than the UVC3 board. Always use the following procedures to prevent damage when handling the board.

1. Leave boards in their anti-static packaging until they are ready to be installed.
2. Dissipate static electricity before handling the board by touching a grounded metal object, such as the machine's unpainted metal chassis.
3. If possible, use anti-static devices such as wrist straps and floor mats.
4. Always hold the board by its edges. Avoid touching the contacts and components on the board.
5. Take care when connecting or disconnecting cables. A damaged cable can cause a short in the electrical circuit.
6. Prevent damage to the connectors by aligning the connector pins before connecting the cable. Misaligned connector pins can cause damage to components at power-on.
7. When disconnecting a cable, always pull on the cable connector or strain-relief loop, not on the cable itself.

Inputs/Outputs - C602 Shake Side

Table 2-7

50 Pin Cable	J10 Connection at UVC J2 Connection at Interface
Pin 2	Receives the viscosity (Hedlund) reading.
Pin 4	Signals the draw solenoid to operate (hold circuit).
Pin 6	Signals the beater motor to operate.
Pin 8	Signals the spinner motor to operate.
Pin 10	Signals the mix pump to operate.
Pin 12	Signals the left glycol solenoid to operate.
Pin 14	Signals the glycol heater to operate.
Pin 16	Signals the glycol pump to operate.
Pin 18	Signals the compressor to operate.
Pin 20	N/A
Pin 22	Interference with this connection displays Power Switch Off (digital switch inputs states).
Pin 24	Enables the test jumper.
Pin 26	Enables the pyroelectric sensor.
Pin 28	N/A
Pin 30	N/A
Pin 32	N/A
Pin 34	N/A
Pin 36	N/A
Pin 38	N/A
Pin 40	N/A
Pin 42	N/A
Pin 44	Signals the optional syrup solenoid to operate.
Pin 46	Signals the vanilla syrup solenoid to operate.
Pin 48	Signals the strawberry syrup solenoid to operate.
Pin 50	Signals the chocolate syrup solenoid to operate.

2

Inputs/Outputs - C602 Sundae Side

Table 2-8

50 Pin Cable	J11 Connection at UVC J2 Connection at Interface
Pin 2	N/A
Pin 4	Signals the draw solenoid to operate (opening solenoid).
Pin 6	Signals the beater motor to operate.
Pin 8	Signals the agitator to operate.
Pin 10	Signals the mix pump to operate.
Pin 12	Signals the right glycol solenoid to operate.
Pin 14	Signals the right syrup heater to operate.
Pin 16	Signals the left syrup heater to operate.
Pin 18	Signals the compressor to operate.
Pin 20	N/A
Pin 22	Causes the LCD to display Beater Motor Overload Fault (digital switch inputs states).
Pin 24	Enables W3 jumper operation.
Pin 26	N/A
Pin 28	Syrup pump speed binary output bit 0.
Pin 30	Syrup pump speed binary output bit 1.
Pin 32	Syrup pump speed binary output bit 2.
Pin 34	Syrup pump speed binary output bit 3.
Pin 36	Syrup pump speed binary output bit 7.
Pin 38	Syrup pump speed binary output bit 6.
Pin 40	Syrup pump speed binary output bit 5.
Pin 42	Syrup pump speed binary output bit 4.
Pin 44	
Pin 46	N/A - Motor reverse control.
Pin 48	
Pin 50	

2

Jumper Pin Function and Configuration Chart

Table 2-9

	UVC4 BOARD	FUNCTION	JUMPER INSTALLED INITIALLY
JP1	PINS 1 AND 2	JUMPER INSTALLED NORMAL APPLICATIONS USING REFRIGERATED MIX.	YES
	PINS 1 AND 2	NO JUMPER INSTALLED-GENERAL MARKET CONFIGURATION USING NON-REFRIGERATED MIX. IGNORES HOPPER TEMPERATURE LOCKOUT PARAMETERS TO ALLOW ADDING NON-REFRIGERATED MIX INTO THE HOPPER.	
	PINS 3 AND 4	JUMPER STORAGE	NO
JP2	PINS 1 AND 2	DOMESTIC CONFIGURATION JUMPER INSTALLED. HOPPER TEMPERATURE NOT DISPLAYED ON SCREEN/HEAT SYMBOL KEYS ONLY ACTIVE WHEN A LOCKOUT CONDITION HAS OCCURRED/STANDBY KEYS DISABLED.	YES
	PINS 1 AND 2	INTERNATIONAL CONFIGURATION-JUMPER NOT INSTALLED. HOPPER TEMPERATURES DISPLAYED ON SCREEN/MANUAL HEAT CYCLE START BY SELECTING HEAT SYMBOL/STANDBY KEYS FUNCTIONAL.	
	PINS 3 AND 4	JUMPER STORAGE	NO
JP3	PINS 1 AND 2	JUMPER INSTALLED ENABLES AUDIBLE DEVICE LOCATED ON UVC3 CONTROL. DISABLED IN MODES THAT HAVE AN AUDIBLE DEVICE ON THE CONTROL PANEL BOARD.	NO
	PINS 3 AND 4	JUMPER STORAGE	NO
	LEFT (SHAKE) INTERFACE BOARD	FUNCTION	JUMPER INSTALLED INITIALLY
JP5	PINS 1 AND 2	JUMPER INSTALLED ENABLES PROXIMITY SENSOR ON SHAKE SIDE FOR VISCOSITY	YES
JP7	PINS 1 AND 2	JUMPER INSTALLED DISABLES RESET	YES
W2		JUMPER INSTALLED RESETS THE URUSH CLEAN DATE WHEN BOTH SIDES ARE IN OFF MODE	NO
W3		JUMPER INSTALLED WILL SIMULATE THE VISCOSITY SETPOINT IF MACHINE IN AUTO	NO
W4		JUMPER INSTALLED FORCES START OF GLYCOL PUMP AND BOTH LEFT AND RIGHT GLYCOL SOLENOIDS ARE ENERGIZED	NO
W5		JUMPER INSTALLED REAL TIME CLOCK CAN BE CHANGED IN ANY MODE	NO
	RIGHT (SOFT SERVE) INTERFACE BOARD	FUNCTION	JUMPER INSTALLED INITIALLY
W2		JUMPER INSTALLED ENABLES 59°F PRODUCT TEMPERATURE CHECK	YES
W3		INACTIVE	NO
W4		INACTIVE	NO
W5		INACTIVE	NO
A	SOFT SERVE PERSONALITY BOARD	0-6 AMP BLADE MOTOR AMPERAGE RANGE	NO
B	SOFT SERVE PERSONALITY BOARD	0-12 AMP HEATER MOTOR AMPERAGE RANGE	YES

2

UVC3 EPROM Chip

Note: Not applicable to UVC4.

The EPROM chip is inserted into a socket on the UVC3 board. The angled corner on the chip identifies the correct position for installation. A PLCC-type extraction tool (part no. 059479) is needed to remove the chip from the socket. (See Figure 2-121.)

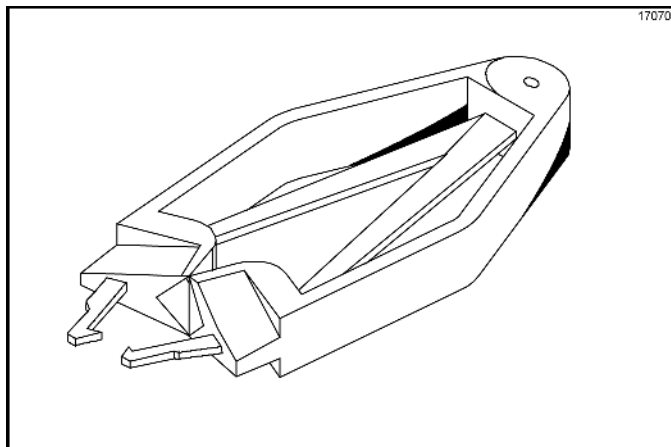

Figure 2-121

Note: Attempting to remove the EPROM from the socket without using the recommended extraction tool may damage the control board.

It is recommended to record the program settings in the Service Menu before replacing the EPROM chip.

You must be properly grounded during chip installations to prevent possible damage to the chip from electrical discharge. The use of a grounding strap is recommended.



WARNING! DO NOT attempt any repairs unless the main power supply to the machine has been disconnected. Failure to do so can result in severe personal injury from electrical shock.

UVC3 RAM Chip

Note: Not applicable to UVC4.

When installing an EPROM chip with a new program version it is recommended to clear the memory in the RAM chip before installing the EPROM chip. (See Figure 2-122 for RAM chip location.)

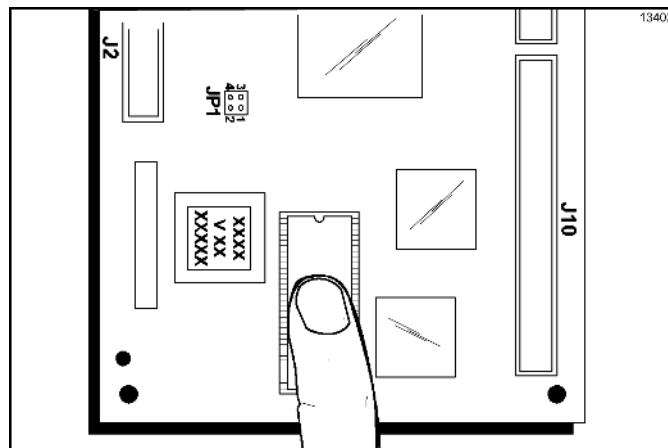

Figure 2-122

To clear the memory, briefly remove the software chip from the socket. Be careful not to bend the pins. To reinstall the chip, align the angled corner of the chip with the angled end of the socket. Partially insert all the pins on one side of the chip into the socket and then all of the pins on the other side. Press the chip firmly into the socket and check to ensure all the pins are in place.

Note: Beginning with software version 1.07, the default settings can be restored in the Service Menu. (See "RESET TO DEFAULTS" on page 2-38.)

UVC3 EPROM Chip Replacement

Note: *Not applicable to UVC4.*

1. Insert the extraction tool pins in the two slots in chip socket. Gently squeeze the tool to raise the chip from the socket. For installation, align the angled corner of the chip and socket and insert the chip until it is fully inserted.
2. Reinstall the control box cover and rear panel and restore the power to the machine.
3. You must first select the language to be displayed on the screen. (See Figure 2-123.)



Figure 2-123

4. During the program initialization, (Language, System Data, Config Data, Lockout Data) the RESET TO DEFAULTS message will display on the screen. (See Figure 2-124.)

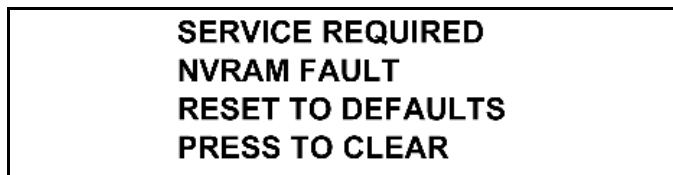

Figure 2-124

5. Clearing the Defaults message will initiate the SAFETY TIMEOUT screen. (See Figure 2-125.)



Figure 2-125

6. After 60 seconds or selecting a key to abort the safety timeout the Power Switch OFF message will appear on the screen. (See Figure 2-126.)

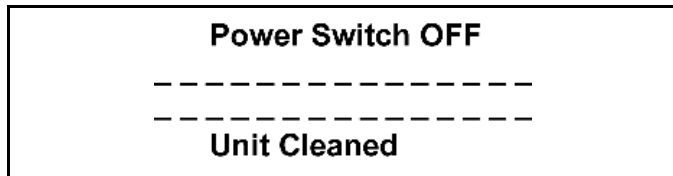

Figure 2-126

7. Place the Power switch to ON, clear the two information screens that appear, and the Unit Cleaned message will be displayed. (See Figures 2-127, 2-128, and 2-129.)

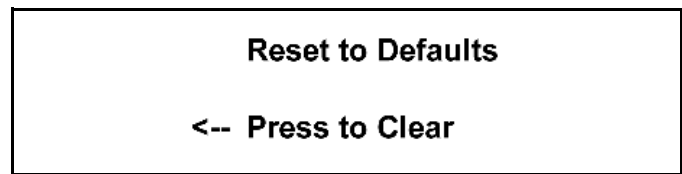

Figure 2-127

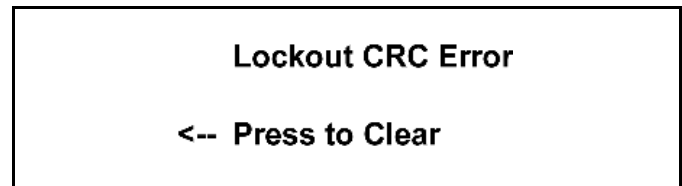

Figure 2-128

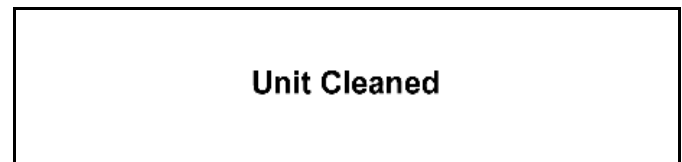

Figure 2-129

8. Immediately access the Service Menu and enter the proper program settings to complete the chip installation.

Interface Boards

Both interface boards are the same for the shake and soft serve side. Ribbon cables provide the communication path between the UVC3/UVC4 and the interface boards. (See "Control Overview - UVC3" on page 2-49.)

A 16VAC transformer supplies the power for the interface boards at Terminals A and B. Each board has a 5VDC output terminal block. Line voltage is connected to the interface boards (L1 and L2) to operate components in the machine on command.

There are four sets of pins (W2, W3, W4, W5) on each interface board. (See "Jumper Pin Function and Configuration Chart" on page 2-56.)

Personality Boards

A personality board plugs into the interface board. The shake proximity sensor (torque coupling sensor) and the portion control pyroelectric board harness are connected to the shake personality board. The soft serve personality board monitors the amperage in one leg of power supplied to the beater motor.

Note: *Beginning with software version 1.11, the soft serve personality board jumper (short) must be placed on the B pins. Prior to version 1.11, the jumper is placed on the A pins.*

Control Panel Interface Board

The Control Panel Interface Board (Dec Plate PCB) is fastened to the back of the tempered glass panel and communicates with the UVC3 through a USB cable.

The control panel has two 5VDC power leads supplied to the board. One connection supplies power to operate the touch sensors and LEDs, and the other 5VDC connection provides power to communicate with the UVC3 control. (See “Control Overview - UVC3” on page 2-49.)

The vacuum fluorescent display (VFD) plugs into a socket on the interface board. The potentiometer dial at the top of the board is non-functional. The VFD does not require a contrast adjustment.

Pins labeled W1 on the face of the Control Panel Interface Board must have a jumper installed to enable the audible tone when a key is selected. (W1 is located next to the audible tone device, below the 5VDC connectors.)

The interface board must have the insulator installed to shield the circuitry on the back of the board. The metal rectifier guard must be installed to shield the interface board from electrical noise.

Motor Speed Control

The motor speed control is powered by 5VDC and receives data bit information through a 10 pin ribbon cable. (See “Control Overview - UVC3” on page 2-49.) The speed control transmits a modulated signal to the syrup motor, therefore the voltage cannot be accurately measured with a meter.

The syrup pump motors run at maximum speed in the Prime mode.

The universal control calculates the motor speed setting in the syrup Calibration mode and sends the information to the speed control.

UVC4 Cables - Factory Installed

2

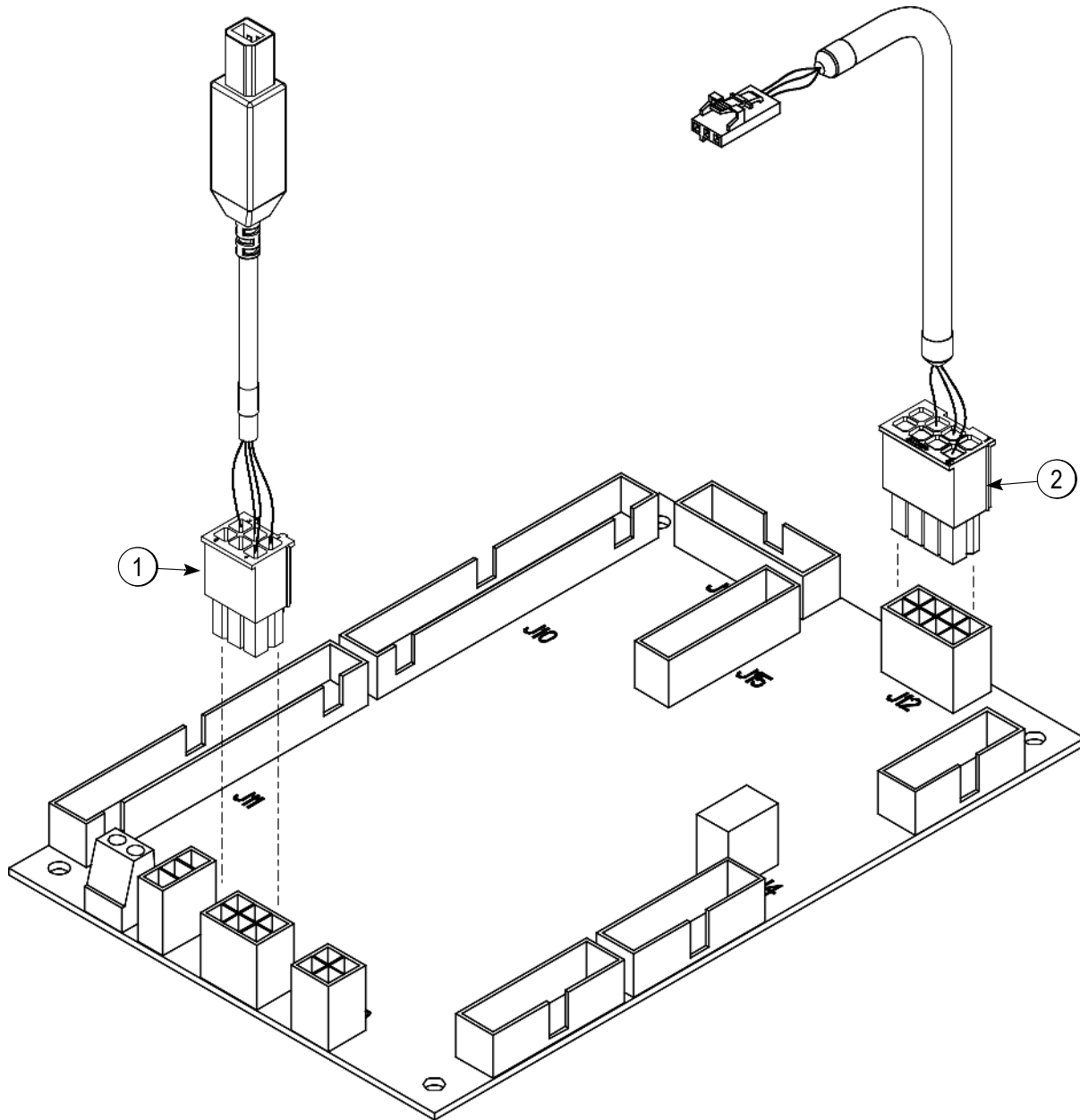
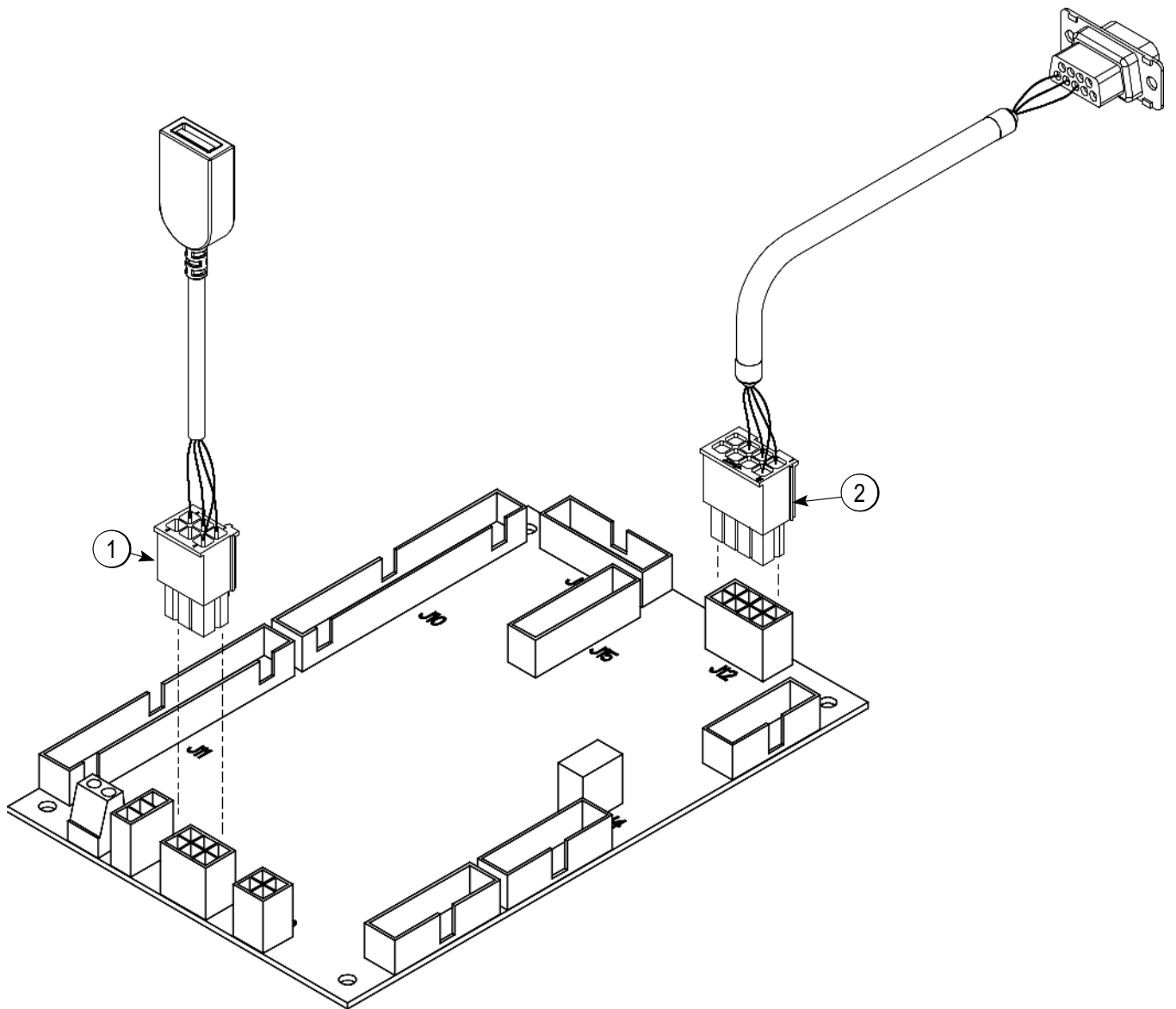

Figure 2-130

Boards installed at the factory have two cables connected to the UVC4 board. Connected at J13 is the USB cable part number 069023 (1) and connected at J12 is the LON Cable part number 069025 (2).

Important! (See "UVC4 Electrostatic Discharge and Proper Handling Procedures" on page 2-53.)

UVC4 Cables - Field Replacements



2

Figure 2-131

The UVC4 board is interchangeable with the UVC3 board. When replacing a UVC3 board in the field, adapter cables are needed. Cable part number 069024 (1) connects to the existing USB cable. Cable part number 069026 (2) connects to the existing LON Cable.

Important! (See “UVC4 Electrostatic Discharge and Proper Handling Procedures” on page 2-53.)

UVC4 Update Instructions

Important!

- (See “UVC4 Electrostatic Discharge and Proper Handling Procedures” on page 2-53.)
 - Before performing software update, reset the control to defaults. This will clear the RAM memory so the new software can be loaded.
 - Only use factory supplied USB drives to perform software update. **Do not** make copies of factory supplied USB drives with generic USB drives. Failure to follow this instruction can cause issues in successfully completing the software update.
 - Wear appropriate personal protective equipment.
1. Enter the Service menu to copy the current machine settings.
 2. Place both sides of the machine into the Off mode and turn the syrup heaters off.



WARNING! DO NOT attempt any repairs unless the main power supply to the machine has been disconnected. Failure to do so can result in severe personal injury from electrical shock.

3. Remove the two drip trays from the upper-rear of the machine and place them on top of the machine.
4. Remove the two screws at the bottom of Panel-Rear-Upper *C602* (066724).
5. Remove the six screws from Cover-Control Box *C602* (066723).
6. Install a jumper onto W2 on the left-side interface board.
7. Reconnect power to the machine and turn the power on. Verify that the display shows Unit Cleaned.
8. Remove the jumper from W2 on the left interface board.
9. Enter the Service menu and go to the option, RESET TO DEFAULTS.

10. Reset to defaults by selecting YES to clear all RAM memory.
11. Install the USB flash drive in the J4 port on the UVC4 board.
12. Check jumper position JP7. Remove the jumper, if present, and do not re-install.
13. Access the Service Menu. Go to Software Update and select YES to begin the update process.
14. Wait 3 minutes for the software to complete the update.
15. After the Lamp Test, enter the Service Menu and clear any faults. Reset machine to defaults.
16. Re-enter all settings copied earlier.
17. Remove the USB flash drive from the UVC4 board and store it in the toolkit.
18. Place both sides of the machine into the Auto mode. Turn the syrup heaters back on, if that was the original state before the installation.
19. Calibrate the syrups. (See “Syrup Calibration” on page 2-80.)
20. Verify that both sides of the machine are operating properly (shutting off at proper viscosity and has no faults).
21. Draw at least one shake and one soft serve cone to verify that the product appearance is acceptable.
22. Carefully re-install the control box cover, the back panel, and the drip trays.

LONWorks® Gateway

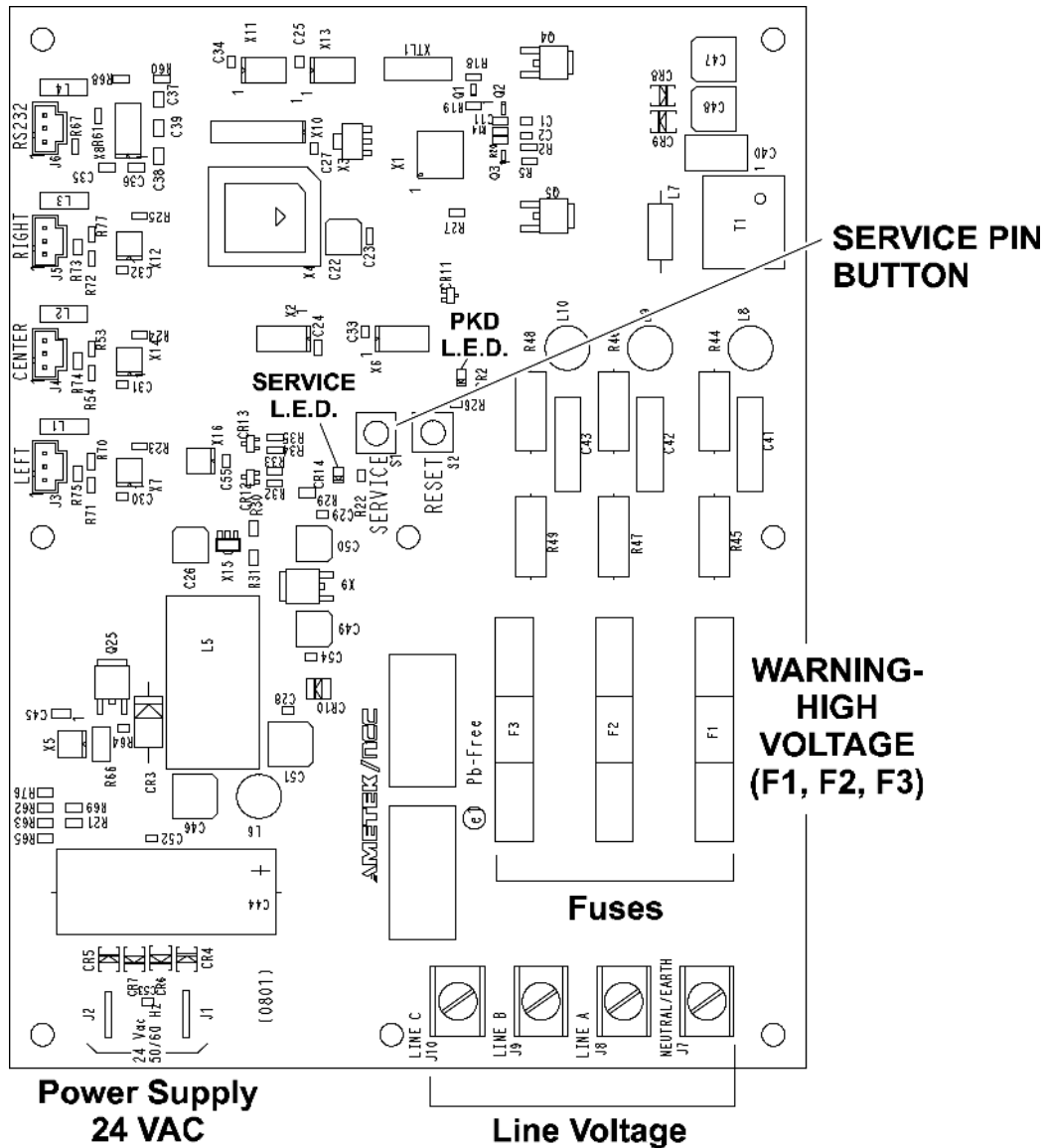

2

Figure 2-132

LONWorks® Gateway is a Smart machine networking solution for McDonald's, using existing power lines to transmit data instead of Ethernet cabling. The LONWorks® Gateway collects data from the machine and send information to a computer in the back room. Users will be able to monitor all Smart machine from a centralized console. Smart Enabled machines will have the ability to change programming/set up in the machine. The gateway is installed in our machine, near the power entry point. A separate 40VA transformer and a Corcom filter provide the power to the LON® Gateway, using 2-1/4 in. spade terminals. In the C602, a cable connects

the gateway to the serial port of the UVC3 board. In Software Revision 1.16, the Manager Menu contains the NET SERVICE PIN option. This option is for future use to activate the gateway, and is not used at this time.

LED Lights:

- PKD (Packet Detect) - Light flashes when receiving messages.
- SVC (Service) - Steady flashing means machine is deactivated.

Electrical System

Modes of Operation

Table 2-10

Component	Heat			Standby	Wash	Auto	Pump	Prime
	Heat	Hold	Cool					
Compressor			X	X		X		
Beater Motor	X	X	X	X	X	X		
Fan			X	X		X		
Spinner Motor (Shake Only)						X		
Air/Mix Pump Motor						X	X	
Syrup Pump						X		
Glycol Heater	X	X						
Agitator	X	X	X	X		X		
Left Glycol Solenoid	X	X	X	X		X		
Right Glycol Solenoid	X	X	X	X		X		
Glycol Pump	X	X	X	X		X		
Shake Draw Solenoid					X	X	X	X

2

L1 Power Path

Power Cord Plugged In / Power Switch in the OFF Position

L1 power from the power cord connection travels through the EMI filter to the 16V transformer. The transformer supplies 16VAC to terminals A and B on the left interface board and right interface board.

The interface boards supply 5VDC to the Universal Control, Personality Boards, Control Panel Interface Board, and the motor speed control.

Power Switch in the ON Position

L1 power from the power cord connection is supplied to terminal L1 on both interface boards. L1 must travel through the following switches to activate the interface board: Power switch, beater overload switch, compressor high pressure limit switch, 15A fuse.

Power Switch On / Mode Select: WASH

With L1 power supplied to the L1 terminal on the interface board, the power is then given to terminal J6, pin 7 to supply power through the interlock relay to the beater motor contactor coil.

Power Switch On / Mode Select: PUMP

With L1 power supplied to the L1 terminal on the interface board, power is then given to terminal J6, pin 5 to supply power to the air/mix pump overload and then to the air/mix pump motor.

Power Switch On / Mode Select: AUTO

With L1 power supplied to the L1 terminal on the interface board, power is then given to terminal J6 and directed through the following pins:

Shake Side

Pin 7 for the beater motor contactor coil (passes through the beater interlock relay).

Pin 5 for the air/mix pump motor (10 seconds only).

Pin 4 for the glycol solenoid.

Pin 2 for the glycol pump motor.

Pin 1 for the compressor contactor coil.

Soft Serve Side

Pin 7 for the beater motor contactor coil (passes through the beater interlock relay).

Pin 6 for the agitator motor.

Pin 5 for the air/mix pump motor (30 seconds only).

Pin 4 for the glycol solenoid.

Pin 3 for the Right Syrup Heater (Heater mode ON).

Pin 2 for the Left Syrup Heater (Heater mode ON.)

Pin 1 for the compressor contactor coil.

Until the hopper thermistor probe is satisfied, the glycol pump will operate on a timed cycle.

Power Switch On / Mode Select: AUTO/Draw Initiated

With L1 power supplied to the L1 terminal on the interface board, power is then given to terminal J6 and directed through the following pins:

Both interface boards

Pin 7 for the beater motor contactor coil (passes through the beater interlock relay).

Pin 6 for the spinner motor (shake side only).

Pin 5 for the air/mix pump. (The pump runs for 10 seconds after the draw handle is closed – soft serve only.)

Pin 1 for the compressor contactor coil. (Compressor delay start based on COMP ON DELAY setting in the Service Menu.)

Power Switch On / Mode Select: AUTO Heat Cycle Activated

From the terminal marked L1 on the interface board, L1 power is sent to terminal J6 and directed through the following pins:

Shake Side

Pin 7 for the beater motor contactor coil (passes through the beater interlock relay).

Pin 4 for the left glycol solenoid.

(Operation of the solenoid is controlled by the shake product thermistor probes which are connected to terminal J10.)

Pin 3 for the glycol heater relay coil.

Pin 2 for the glycol pump.

CONTROLS

Soft Serve Side

Pin 7 for the beater motor contactor coil (after the freezing cylinder has reached 135°F [57°C]).

(Note: Power must go through the beater interlock before reaching the coil.)

Pin 6 for the agitator motor.

Pin 4 for the glycol solenoid.

(Operation of this solenoid is controlled by the soft serve glycol thermistor probe which is connected to terminal J10.)

Operation of the glycol heater is controlled by the glycol thermistor probe which is connected to terminal J10 of the shake interface board.

At the completion of the Heat and Hold phases of the heat treatment cycle, the glycol heater stops, and the main compressors are activated from terminal J6 pin 1 on the interface boards.

Once the freezing cylinder and hopper thermistor probes (connected to terminal J10 on the interface board) have been satisfied, the heat treatment cycle will end.

Shake Draw

Shake Draw Sequence Chart

Refer to the following chart for the normal operating sequence when a shake is dispensed in the Auto mode.

Table 2-11

Sequence	Component		Shake Interface Board	Soft Serve Interface Board
Flavor key Selected in Auto Mode	Activate	Flavor Selection LED	-	-
	Start	Beater Motor	J6-T7 / J7-T1	-
	Start	Pump Motor	J6-T7 / J7-T2	-
	Start	Spinner Motor	J6-T6 / J7-T1	-
	Start	Syrup Motor	J5-T1 / J5-T2, 3, 4, 5	-
	Energize	Draw Solenoid Pull Relay	-	J5-T7 / J5-T8
	Energize	Draw Solenoid Hold Relay	J5-T7 / J5-T8	-
Dispensing	0.25 Seconds From Start of Draw			
	De-Energized	Draw Solenoid Pull Relay	-	J5-T7 / J5-T8
	*2.0 Seconds From Start of Draw			
	Energized	Compressor Contactor Coil	J6-T1 / J7-T7	-
	Activate	Control Monitors Pyro-Sensor Voltage (0.1VDC)	J3-T3 and T4	-
Fill Level Detected by Pyro-Sensor / or Flavor key Selected	Fill Detected	5VDC Detected at Personality Board	J3-T3 and T4	-
	Start	Whitespot Timer	-	-
	Stop	Syrup Pump Motor	J5-T1 / J5-T2, 3, 4, 5	-
	*Whitespot Timer Countdown (0.2 sec. to 0.4 sec.)			
Close Draw Valve and Reverse Syrup Flow	Turn OFF	Flavor Selection LED	-	-
	Stop	Mix Pump Motor	J6-T7 / J7-T2	-
	Stop	Spinner Motor	J6-T6 / J7-T1	-
	De-energized	Draw Solenoid Hold Relay	J5-T7 / J5-T8	-
	Start	Reverse Syrup Motor	-	J5-T1 / J5-T2
	*Syrup Motor Reverse Timer (0.25 to 0.28)			
(0.5 second Delay)	Stop	Spinner Motor	J6-T6 / J7-T1	-
Viscosity Setting Achieved - Cycle OFF	Stop	Compressor	J6-T1 / J7-T7	-
	Stop	Beater Motor	J6-T7 / J7-T1	-
	Start	Off Cycle Stir Timer	-	-

*Adjustable setting in Service Menu

2

Shake Draw Solenoid Electrical Circuit With Rectifier Board
 (Prior to Serial Number K6081879)

2

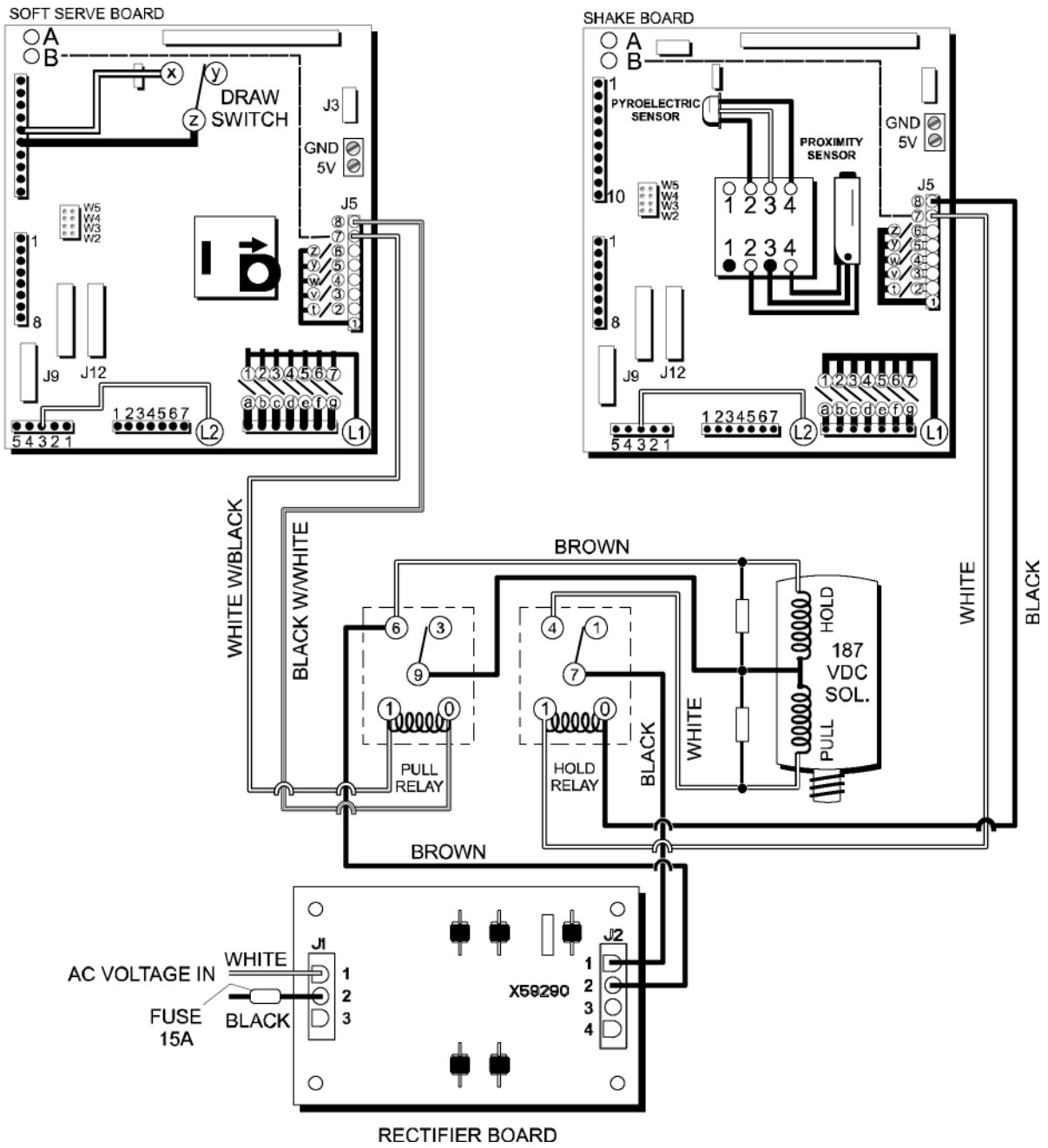

Figure 2-133

Shake Draw Solenoid Electrical Circuit - 24V Transformer/Rectifier PCB

2

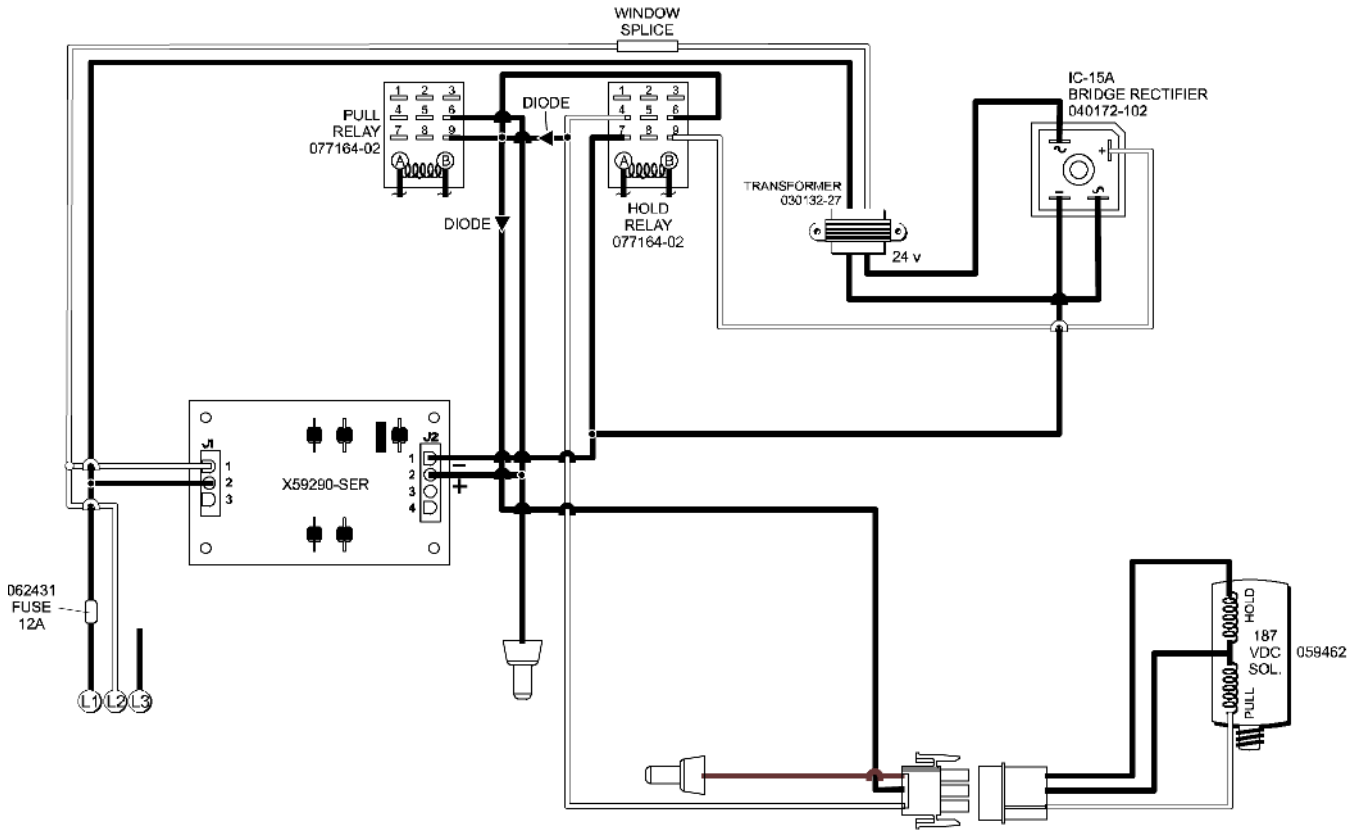

Figure 2-134

Shake Draw Solenoid Electrical Circuit - 24V Transformer/IC Rectifier

2

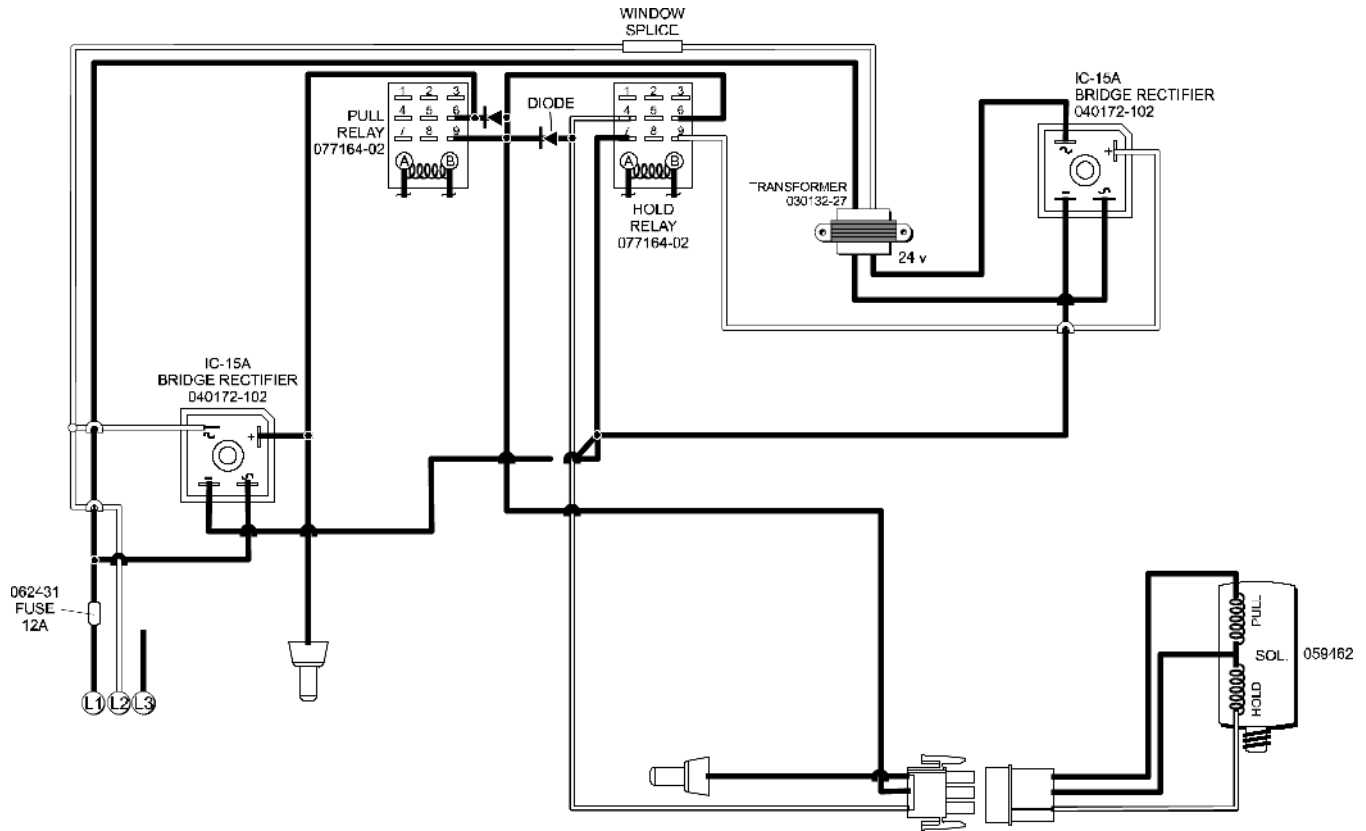

Figure 2-135

Draw Solenoid (059462-CP)

Draw Solenoid Voltage VDC

The draw solenoid has a 187VDC coil. The coil is energized by direct current supplied from the rectifier board passing through the pull and hold relays to open the draw valve.

The pull circuit is only momentarily powered (approximately 0.25 second) when the plunger is raised. The hold circuit in the solenoid remains powered to keep the plunger in the raised position.



CAUTION! Pinch Hazard.

DO NOT place fingers or other objects under the raised plunger. The plunger closes forcefully when power is interrupted. Failure to comply may result in personal injury from moving parts or damage to the machine.

Check the hold circuit voltage by inserting meter leads into the wire connector, black (center) wire, and brown wire.

If a low voltage reading is detected, check the power supply from the rectifier board and the hold relay.

The height of the solenoid coil must be properly set to pull up the plunger. (See “Shake Dispensing Alignment Procedure” on page 2-73.)

Draw Solenoid Windings Resistance

Unplug the three-pin connector leading to the draw solenoid. Check the resistance with an accurate meter. Replace the draw solenoid if either circuit is found shorted or open.

PULL Circuit:

Attach meter leads to the white wire and the black (center) wire.

Pull circuit resistance = 60.9 ± 3.0 ohms

HOLD Circuit:

Attach meter leads to the black (center) wire and the brown wire. (Note: The brown wire may be a black/white stripe on some solenoids.)

Hold circuit resistance = $1,165.0 \pm 58.25$ ohms

Pull and Hold Relays (077164-02)

The pull and hold relays have a 12VDC coil that is energized to pass power through the contacts to the draw solenoid. Both relays are energized simultaneously when dispensing a shake.

The Pull Relay coil receives 12VDC from the Soft Serve Interface Board (J5) and is momentarily energized to raise the plunger. The Hold relay receives 12VDC from the Shake Interface Board (J5) and remains energized to hold the plunger in the raised position.

Note: *The pull relay is only momentarily energized, so it is difficult to check the relay coil and contacts with a meter. It may be necessary to swap the pull and hold relays to determine if the pull relay is defective.*

Pull/Hold Relay Diodes

Each relay for the draw solenoid has a diode to stop voltage from surging back through the circuitry when the solenoid is de-energized. The diodes allow the flow of current in one direction. Normally the diodes do not fail unless another component in the circuit causes an extreme electrical load on the device. A shorted diode may trip the L1 circuit fuse in the front control channel (Part No. 062431 Fuse-12 Amp-Non Delay).

Checking Diode Resistance

Use an ohmmeter to determine if a diode is open or shorted. The wire harness must be disconnected from all components to check the diode resistance.

1. Disconnect the draw solenoid, rectifier board, and the relays from the wire harness containing the two diodes.
2. Measure the resistance across the diode. Reverse the position of the red and black leads to the meter, and check resistance again. A good diode will show a high resistance reading in one direction and infinite resistance (open) when the leads are reversed.

If a relay diode is found defective, replace the complete harness (Part No. 059478 Harness-Rectifier/Relay/Solenoid).

Rectifier Board (X59290)

The dual bridge rectifier board converts alternating current to direct current for energizing the draw solenoid coil. The board receives input voltage when power is supplied to the machine. The output voltage (DC) will be approximately 1.414 times higher than the Input voltage (AC).

Output Voltage = 1.414 X Input Voltage.

Example: 210VAC input x 1.414 = 297VDC output.

2 **Note:** *The output voltage will drop under a load (draw solenoid energized).*

Integrated Circuit (IC) Rectifier (040172-102)

The IC Rectifier converts alternating current to direct current to energize the draw solenoid coil. Two IC rectifiers are used in the circuit to power the draw solenoid. One rectifier receives line voltage and transmits DC voltage through the pull relay to raise the draw solenoid plunger. The second rectifier converts the low voltage from the transformer to direct current to hold the plunger in the raised position.

One input terminal is labeled with the key for alternating current (~). One output terminal has a positive key (+). The matching terminals for the input and output are positioned diagonally across the rectifier. (See "Shake Draw Solenoid Electrical Circuit - 24V Transformer/IC Rectifier" on page 2-70.)

CAUTION: Improper wiring will damage the IC Rectifier and other components in the circuit.

The normal output voltage from the rectifier will read slightly higher than the input voltage when a load is not present. Under a load condition the voltage will drop slightly. For example, the low voltage output from the rectifier powered by the transformer may drop to 17V to 18V when the solenoid is energized.

There are four diodes in the IC Rectifier. A shorted diode may trip the fuse in the control channel. To check for a faulty diode, measure the resistance between the AC terminals (~) to the positive terminal (+). Reverse the meter leads to the same terminals and check the resistance again. A good diode will show a high resistance reading in one direction and a low resistance when the meter leads are reversed. Repeat the same check by measuring the resistance between the AC terminals (~) and the negative output terminal (-) which is diagonally across from the positive terminal.

Transformer (030132-27)

The 24VAC output from the transformer is converted to direct current by the IC Rectifier.

Inspect Solenoid Plunger For Wear

Check the solenoid plunger for signs of wear. A worn solenoid plunger will cause the shake draw valve to fail to open or close properly. The plating residue from the worn plunger creates an abrasive surface inside the solenoid coil, causing the plunger to bind.

Replace the complete solenoid (coil, plunger, and spring) if the plunger is worn.

Note: *The draw solenoid plunger changed to chrome plating, beginning with serial number K6024286.*

Shake Dispensing Alignment Procedure

There are five areas that must be properly aligned in the shake draw mechanism:

- Actuator Plate
- Spinner Motor Bracket
- Solenoid Valve
- Spinner Motor
- Spinner Coupling

All adjustments must be performed with the freezer door assembled and installed, with the handscrews secure. Tighten the handscrews in a crisscross pattern so the door is drawn up flush on the cylinder face. (See Figure 2-136.)

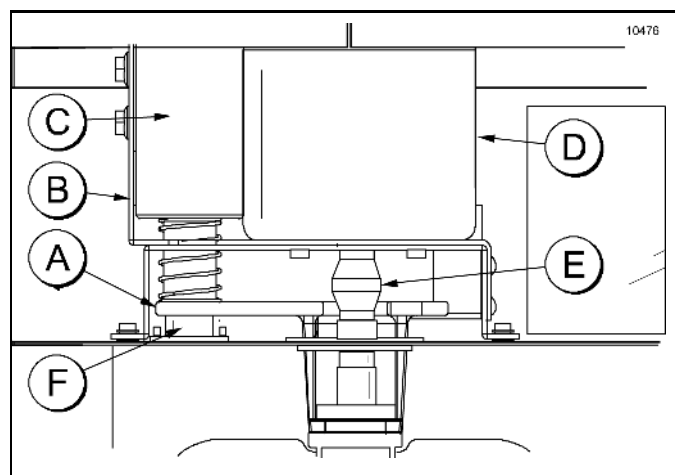

Figure 2-136

Table 2-12

Item	Description
A	Actuator Plate
B	Spinner Motor Bracket
C	Solenoid Valve
D	Spinner Motor
E	Spinner Coupling
F	Bumper

Actuator Plate Alignment

The actuator plate (lifter) must be centered to fit in the draw valve slot. (See Figure 2-137.)

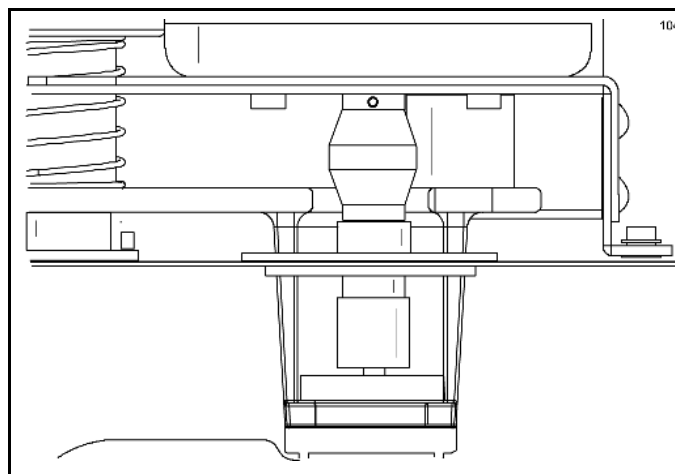

Figure 2-137

Use the freezer door assembly to check the actuator alignment. The actuator should slide easily into the draw valve slot when the freezer door is installed. Loosen the set screw and the plunger. Remove the bumper access plate and the screws. Adjust the actuator by loosening the bumper screw secured to the solenoid plunger.

To adjust the alignment, perform the following steps:

1. With the bumper access plate removed and the bumper screw loose, align the actuator with the slot in the draw valve (side-to-side alignment).
2. Secure the bumper screw. Retighten the set screw and the plunger. Check to make sure the bottom of the solenoid plunger is secured to the actuator plate.

The actuator should slide easily into the draw valve slot when the freezer door assembly is installed.

(See Figure 2-138.)

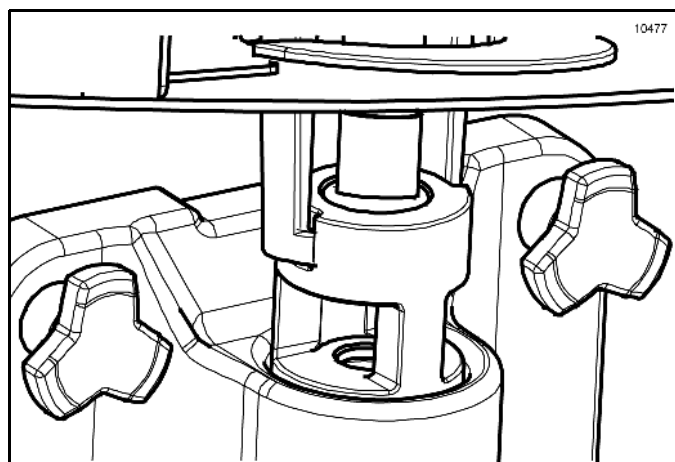

Figure 2-138

Spinner Motor Bracket

The actuator plate should not contact the white guide post mounted underneath the spinner motor bracket. The primary function of the guidepost is to prevent the actuator from pivoting backward when the freezer door is installed. (See Figure 2-139.)

Important! When properly aligned, the actuator must move freely without any tension on the guide post.

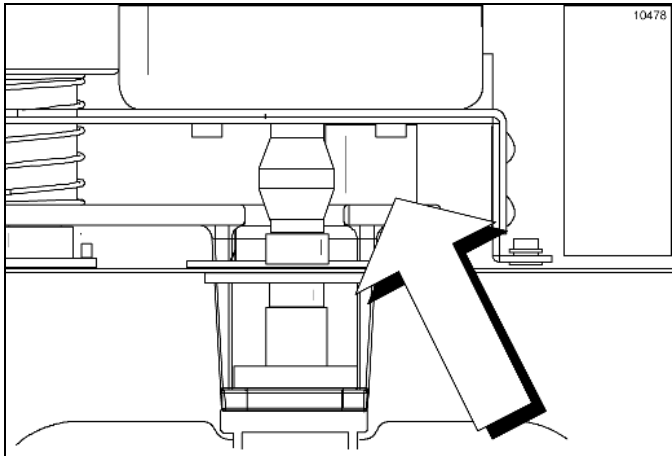

Figure 2-139

To adjust the alignment, perform the following steps:

1. Loosen the four hex-head screws that secure the spinner motor bracket to the control channel bracket.
2. Slide the bracket forward or backward to the correct position and secure the four screws.

Solenoid Valve Height Position

The height of the solenoid must be positioned to raise the draw valve to the top of the product port in the freezer door. If the solenoid coil body is too high, the magnetic force to pull the plunger into the coil will be reduced. This may cause the solenoid to not open when other load factors influence the movement of the draw valve, such as lack of lubricant, misalignment, product too cold, etc.

If the solenoid is positioned too low, the draw valve will not raise high enough to fully open the product port in the door. The flow rate for the frozen mix will be reduced and the syrup blended in the shake will be greater than the calibrated amount. You may also notice that it takes longer than normal to drain the freezing cylinder when rinsing the machine.

Note: The solenoid position can be adjusted while there is product in the freezing cylinder. Relieve the freezing cylinder pressure by dispensing frozen product in the Wash mode without pump operation before performing the adjustment procedure.

To adjust the solenoid height, use the Solenoid Adjust Tool Kit Assembly (X59702) and perform the following steps:

1. Place the power switch to the OFF position and disconnect power to the machine.



WARNING! Make sure the power switch is in the OFF position. Failure to follow this instruction may result in severe personal injury from hazardous moving parts.

2. Remove the front control panel.
3. Loosen the two 7/16 in. nuts that secure the draw solenoid to the mounting bracket. The solenoid spring tension will push the coil to the top of the adjustment slots in the bracket.
4. Loosen, but do not remove, the solenoid plunger set screw and the bumper screw.
5. Remove the restrictor cap, spinner blade, and the driven spinner from the shake door.
6. Using sanitizing solution, rinse the area below the draw valve.
7. Lubricate the two O-rings and install the solenoid adjust tool into the door spout. Lift the draw valve to insert the tool into the door. Install the restrictor cap to retain the tool with the draw valve in the raised position. (See Figure 2-140.)

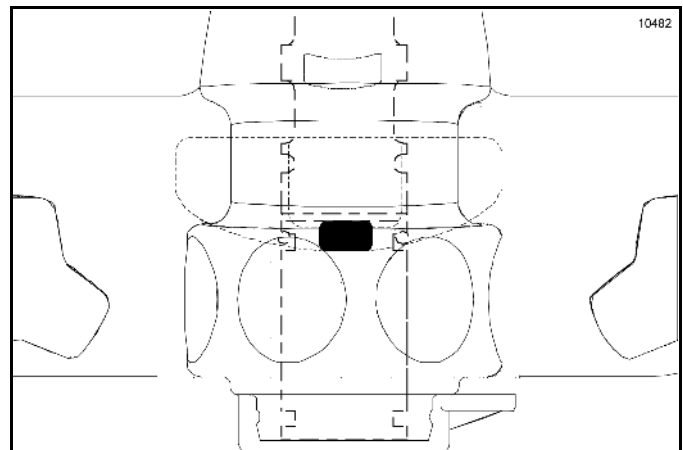

Figure 2-140

8. Lower the solenoid until the top of the plunger contacts the top surface (stopping point) inside the coil body. (See Figure 2-141.) Make sure the solenoid is aligned vertically and then retighten the two 7/16 in. nuts to secure the solenoid.

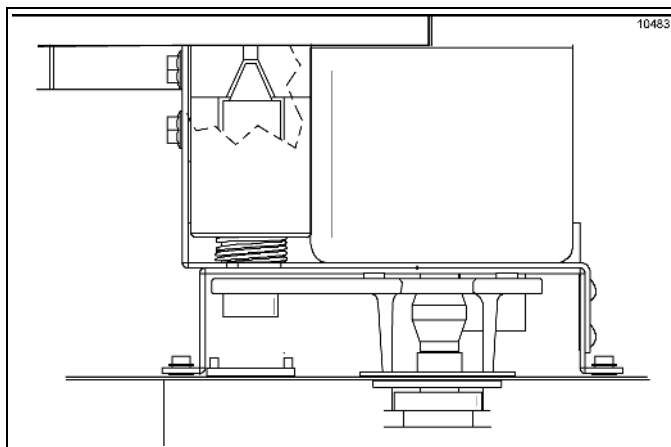

Figure 2-141

9. Remove the restrictor cap and tool.
10. Sanitize, lubricate, and reinstall the driven spinner and spinner blade. Install the restrictor cap.
11. Raise the draw valve manually a few times to align the actuator plate with the solenoid plunger. When they are aligned, tighten the bumper screw and the plunger set screw. Reinstall the access plate.
12. Install the front control panel and restore power to the machine.
13. Dispense several shakes to check for proper draw valve performance.

Spinner Motor

The spinner motor shaft must be centered in the draw valve. The spinner blade shaft must insert into the center of the spinner coupling. (See Figure 2-142.)

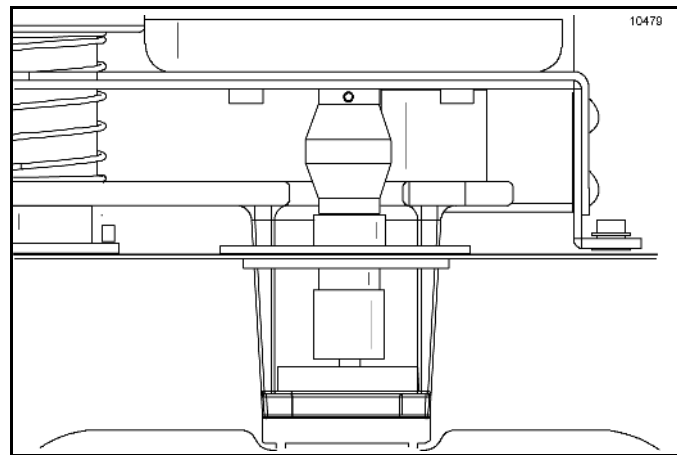

Figure 2-142

2

Spinner Motor Alignment Procedures

1. Loosen the four screws that secure the spinner motor to the bracket. With the freezer door assembly installed, insert the spinner blade into the coupling.
2. Position the motor so the spinner shaft is centered with the coupling.
3. Tighten the two front screws.
4. Remove the door to tighten the rear screws.

Note: A spinner alignment tool is available to assist with alignment procedures. (See Figure 2-143.)

Spinner Coupling

The coupling must be adjusted so the spinner blade is recessed 1/32 in. (0.8 mm) or less in the bottom of the door spout.

To adjust the alignment, perform the following steps:

1. Assemble the freezer door.
2. Loosen the top screw that secures the coupling to the spinner motor shaft.
3. Position the coupling so the bottom of the spinner is recessed 1/32 in. (0.8 mm) or less in the bottom of the door spout.
4. Retighten the coupling screw.

Note: A spinner alignment tool is available to assist with alignment procedures (See Figure 2-143.)

Spinner Alignment Tool

To aid in the alignment of the draw valve, spinner motor, and spinner shaft, a spinner alignment tool is available (Part No. 068036). (See Figure 2-143.)

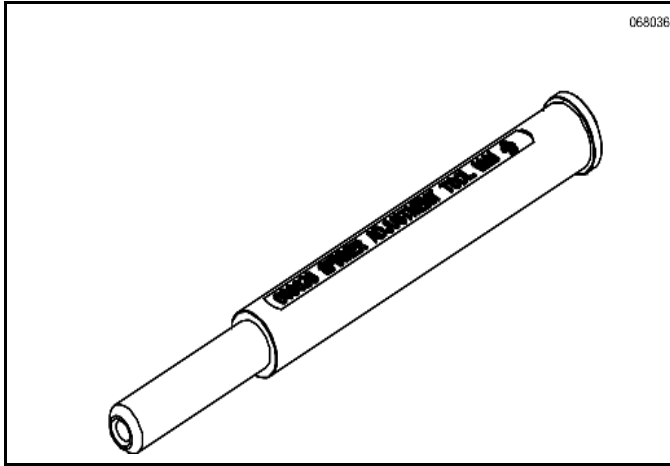

Figure 2-143

During draw valve solenoid adjustment, the small hole in the bottom of the alignment tool can be used to add torque to the Allen wrench when loosening the setscrew.

During spinner motor alignment, the alignment tool can be inserted into the draw cavity and pushed up until the top of the tool touches the spinner motor shaft. If the motor is properly aligned, the spinner motor shaft will fit into the hole at the top of the spinner alignment tool. If an adjustment is needed, the alignment tool can be installed into the draw valve cavity and the motor adjusted until the shaft fits into the hole at the top of the tool. When the draw valve solenoid is properly aligned, the bevel in the alignment tool will line up with the arm bracket.

This tool can also be used to position the drive spinner and the spinner shaft. The wide end of the spinner alignment tool is used to push the shaft up until the bevel on the alignment tool is even with the bottom of the door.

Note: For complete instructions to align the draw valve solenoid, spinner motor, and spinner shaft, refer to Service Bulletin S2693, dated 4/13/10.

Syrup

Syrup Delivery

Shake syrup is stored in the lower front compartment. Each syrup flavor is delivered to the dispensing door by a peristaltic pump. Syrup can be pumped directly from disposable plastic jugs, stainless steel tanks, or adapted to syrup-in-bag dispensing. The proper syrup delivery rate is achieved by calibrating each syrup flavor.

A 24VDC motor drives each peristaltic pump. In Auto mode, the UVC3 control regulates the motor speed

necessary to dispense syrup at the calibrated rate.

The pump motors run at maximum speed in the Syrup Prime mode.

A relay is used to reverse the rotation of the syrup pump motor each time the pump operation is discontinued. The syrup flow must be momentarily reversed in order to drop the pressure in the line and close the duckbill syrup valve.

(See "SYRUP MOTOR SETUP" on page 2-35.)

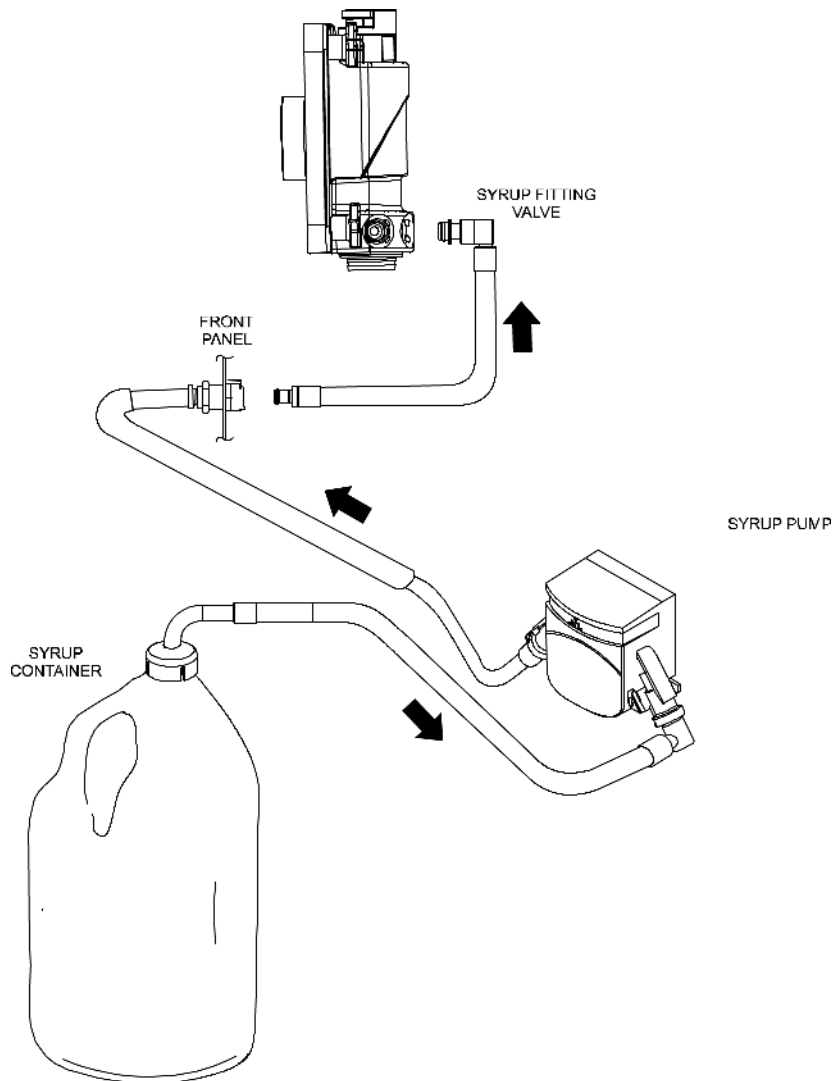

Figure 2-144

Syrup Motor Set Up

To achieve the optimum setting for calibrating each syrup flavor, the motor speed settings in the Service Menu must be adjusted. The objective is to program the motor speed for each syrup flavor to have a calibration time as close as possible to the CAL Syrup Time setting (7 seconds for triple thick shake syrup and 5 seconds for thin syrups). The speed at which the peristaltic pump runs during the Calibrate mode should be adjusted on all new machine installations whenever the control settings are reprogrammed, or if the amount of syrup dispensed in VERIFY Calibration does not match the calibrated amount.

Chart A: Triple Thick Shake Syrup

Table 2-13

Flavor	Motor Speed	Reverse Time
Chocolate	70 to 80	0.28
Strawberry	80 to 100	0.28
Vanilla	60 to 80	0.25
Optional	50 to 80	0.25

Chart B: Thin Shake Syrup

Table 2-14

Flavor	Motor Speed	Reverse Time
Chocolate	50 to 80	0.25
Strawberry	50 to 80	0.25
Vanilla	50 to 80	0.25
Optional	50 to 80	0.25

Perform the following four steps to adjust the syrup motor speed setting in the Service Menu for each flavor.

1. Menu Selection: Syrup Motor Setup

Adjust the speed setting that the syrup pump motor will run in the Calibration mode. Select a motor speed for the flavor within the range on the above chart, depending on the type of syrup. Adjust the reverse time to the recommended setting on the chart.

2. Menu Selection: Syrup Calibration

Calibrate each flavor using the small chamber on the divided cup. (Taylor Part No. 017203)

Note: If the syrup pump rollers do not turn or the syrup dispenses extremely slow in the Calibration mode, increase the motor speed setting by 10 and check the dispensing rate again. Increase the motor speed setting until you have a steady, manageable flow rate to calibrate the syrup flavor.

3. Menu Selection: Verify Calibration

Select each flavor and compare the amount of syrup dispensed in verify calibration versus the calibrated amount. If the amount in Verify Calibration is within 1/16 oz. of the calibrated amount, the speed setting is correct.

If the amount of syrup dispensed in verify calibration is more than 1/16 oz. above or below the calibrated amount the motor speed setting needs to be adjusted. (Proceed to Step 4.)

4. Menu Selection: Syrup Motor Setup Verify Too High:

If the amount of syrup dispensed is more than the calibrated amount, increase (raise) the motor speed setting.

Example: Calibrated amount = 1.0 oz. but verify calibration amount = 1-1/4 oz. Adjust the speed to a higher setting, recalibrate the flavor, and repeat Step 3.

Verify too low: If the amount of syrup dispensed is less than the calibrated amount, decrease (lower) the motor speed setting. Example: Calibrated Amount = 1.0 oz. but verify calibration amount = 3/4 oz. Adjust the speed to a lower setting, recalibrate the flavor, and repeat Step 3.

Each time the motor speed setting is adjusted you must re-calibrate the flavor and check the amount dispensed in verify calibration.

If the amount of syrup dispensed in verify calibration does not change when making the motor speed setting adjustments, a new pump tube should be installed.

Adjust the motor speed setting until the amount dispensed in verify calibration is within 1/16 oz. of the calibrated amount.

Additional Operating Tips

- During each syrup calibration, the control measures the amount of time between the flavor key selections to start and stop the syrup flow. The control calculates the dispensing speed to run the motor, using the time and the motor speed set point in the Service Menu.
- **Default Speed:** If the calculation should result in a motor speed of 32 or less, the dispensing speed will default to 128. This will occur if the flavor key was selected too soon or the motor speed is set too fast for the type of syrup used in the machine.
- Chart C shows the minimum time for Calibration based on the CAL SYRUP TIME set point. If the time between key selections (start to stop) in CALIBRATE SYRUP is less than the time on the chart, the dispensing speed will default to 128. It may appear to the technician that the control will not calibrate properly. The correct action would be to determine the cause for the motor running at the default speed. Examples: The motor speed is set too high, the syrup calibrated was less than 1 oz., or improper ribbon cable connection.

Chart C: Default Speed 128

Table 2-15

Cal Syrup Time = 7 Seconds		Cal Syrup Time = 5 Seconds	
Motor Speed	Time (Seconds)	Motor Speed	Time (Seconds)
60	3.7	60	2.7
80	2.8	80	2.0
100	2.2	100	1.6

- **Can't Calibrate:** The message CAN'T CALIBRATE will be displayed when the control calculates a dispensing speed that is more than 255. Chart D shows the maximum time values at various motor speed settings based on the CAL SYRUP TIME set point. If the Calibration time at the specified speed takes longer than the time on the chart, the dispensing speed will automatically default to 255 and the CAN'T CALIBRATE message will be displayed. Typically, the CAN'T CALIBRATE message is an indication that the peristaltic pump tubes are worn and need to be replaced. It may also indicate the restaurant is priming the syrup lines in the Calibration mode by mistake.

Chart D: Can't Calibrate Message

Table 2-16

Cal Syrup Time = 7 Seconds		Cal Syrup Time = 5 Seconds	
Motor Speed	Time (Seconds)	Motor Speed	Time (Seconds)
80	22	80	16
100	18	100	13
120	15	120	11
140	13	140	9
160	11	160	8





Syrup Calibration

Calibrating the syrup flow should be performed weekly when the syrup system is cleaned. It is vital that the correct amount of syrup be incorporated into the frozen mix to obtain a quality shake.

To determine the rate of syrup flow, you will need a Calibration Cup indicating fluid ounces. The proper rate of syrup flow is 1 fl. oz. (30 ml) of syrup in 5 seconds. For triple thick shake syrups, the proper syrup flow rate is 1 fl. oz. +/- 1/8 fl. oz. (30 ml +/- 4 ml) in 7 seconds. Once this rate is set, the correct amount of syrup will be blended with the shake base regardless of the size of shake served. Please note that syrup calibration is critical when changing the promotional fourth flavor syrup.

Calibration Procedure

Syrup lines must be properly primed with syrup to eliminate air in the line before the Calibration procedure is performed.

1. Press the Calibration key  to display the menu options. The Calibration key , the Auto key  on the shake side, and the Flavor Selection key  will be illuminated. (See Figure 2-145.)

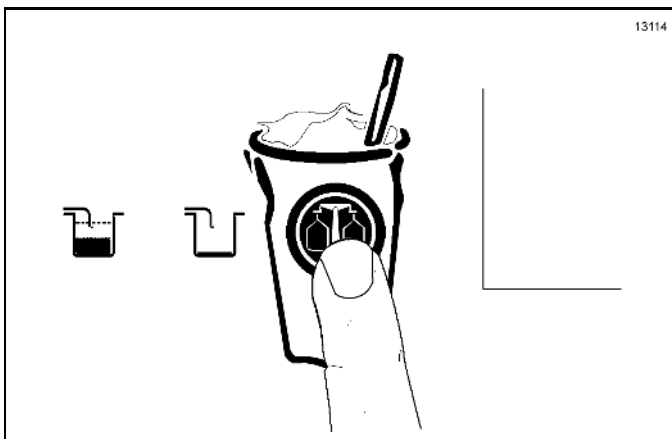



Figure 2-145

The screen will display the Calibration menu options. (See Figure 2-146.)



**UNFLAVORED DRAW
SYRUP CALIBRATION
SYRUP PRIME
EXIT**

Figure 2-146

When the Calibration screen is displayed, the Flavor

Selection keys  will not raise the draw valve to dispense shake product.

Note: The unflavored draw option will only appear on the screen when the shake side is in the Auto mode.

2. Press the Auto key  or the Flavor Selection key  to scroll the cursor (>) to SYRUP CALIBRATION. (See Figure 2-147.)

**UNFLAVORED DRAW
SYRUP CALIBRATION
SYRUP PRIME
EXIT**

Figure 2-147

3. Press the Calibration key  to enter the SYRUP CALIBRATION mode. (See Figure 2-148.)

**SYRUP CALIBRATION
Select a Flavor
< Press to Clear**

Figure 2-148

4. Disconnect the syrup valve from the freezer door. Raise the syrup valve retainer and pull the valve straight out. (See Figure 2-149.)

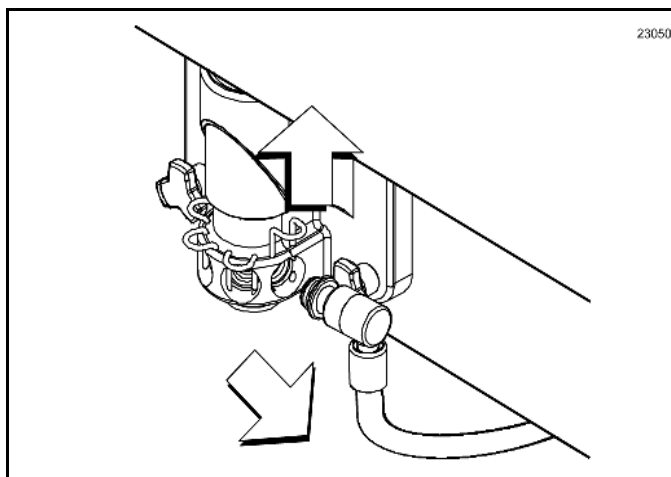

Figure 2-149

5. To calibrate the syrup dispensing rate, hold the small portion of the calibration cup under the valve for the flavor to be calibrated. Touch the corresponding

Flavor Selection key to activate the syrup pump and start the flow of syrup. When the syrup level measures 1 oz., touch the same Flavor Selection key

to stop the syrup flow.

Verify the level of syrup in the cup. If the measurement is not within the specification, repeat Step 4 for the same flavor until the correct syrup Calibration is achieved. (See Figure 2-150.)

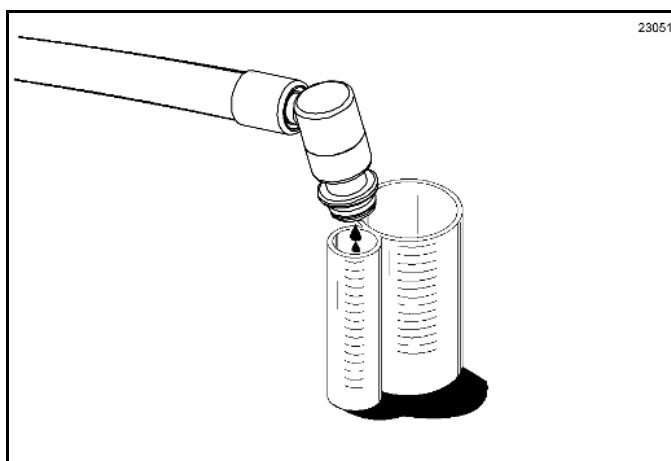

Figure 2-150

Note: You can verify the syrup dispensing rate in the Manager's Menu or the Service Menu.

Repeat steps 4 and 5 for the remaining syrup flavors. If the Calibration time exceeds the maximum motor speed the Can't Calibrate message will appear on the screen. (See Figure 2-151.)

(See "Peristaltic Syrup System Troubleshooting Guide" on page 3-7.)

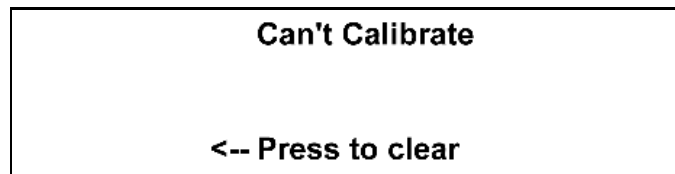



Figure 2-151

6. Exit the Calibration mode by touching the Calibration

key . A blank screen will appear and the Auto

key  and the Flavor Selection key will return to their normal function.

Note: Whenever a particular syrup line is not used, the syrup hole plug in the spare parts kit must be installed. Place the syrup hole plug O-ring into the groove of the syrup hole plug and lubricate it. Install the hole plug in the door. Lower the retaining pin to secure the plug in place.

Dispensing Shakes Without Syrup

Beginning with software version 1.04, shakes can be dispensed without flavoring by selecting the left side

Pump key .

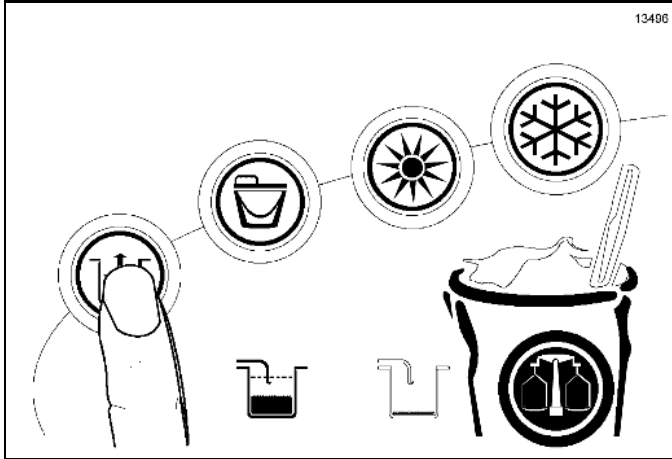

Figure 2-152

The following screen will display:

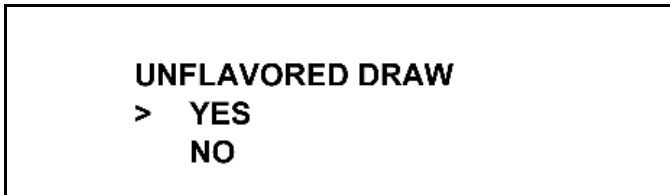





Figure 2-153

Select the Calibration key . The left side Pump key illuminates and unflavored product immediately starts to dispense. The unflavored draw ends and the Pump key is no longer illuminated when the pyroelectric sensor detects the cup is full. The unflavored draw can also be terminated by selecting the Pump key a second time.

Note: To cancel the UNFLAVORED DRAW screen,

touch the Flavor Selection key  to move the

cursor (>) to NO, then press the Calibration key .

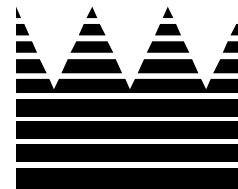

Section 3: Troubleshooting

- **General Troubleshooting Guide**
- **Air Mix Pump System Troubleshooting**
- **Peristaltic Syrup System Troubleshooting Guide**
- **Shake Dispensing Mechanism Troubleshooting**
- **Shake Portion Control Troubleshooting**
- **Pyroelectric Sensor Troubleshooting**
- **Bacteria Troubleshooting**

General Troubleshooting Guide

Table 3-1

Problem	Cause	Remedy
1. Compressor will not run.	<ul style="list-style-type: none"> a. The power switch is in the OFF position. b. An incorrect key was pressed. c. The contactor is faulty. d. The compressor has burned out. e. The fuse or circuit breaker has blown. f. Tripped overload (compressor). g. Off on reset (beater motor). 	<ul style="list-style-type: none"> a. Place the power switch in the ON position. b. Press the correct key for Auto mode. c. Replace the contactor. d. Replace the compressor. e. Replace the fuse, or turn on the breaker f. Place the power switch in the OFF position, and allow the compressor to cool and the overload to close before returning the power switch to the ON position. g. Press the RESET button.
2. Machine operates long (cycles off on the 11-minute safety timer).	<ul style="list-style-type: none"> a. Condenser is dirty. b. Air filter is dirty. c. Shortage of refrigerant. d. Air in the system. e. High overrun product. 	<ul style="list-style-type: none"> a. Clean the condenser. b. Replace the air filter. c. Repair the leak and recharge machine. d. Purge and recharge the system. e. Check pump operation for correct air/mix ratio.
3. Head pressure is too high.	<ul style="list-style-type: none"> a. Condenser is dirty. b. Air filter is dirty. c. Water valve is out of adjustment or is restricted. d. Insufficient airspace around machine. e. Refrigerant overcharge. f. Blower is faulty. g. The air deflector is not properly installed, recirculating warm air into the condenser. 	<ul style="list-style-type: none"> a. Clean the condenser. b. Replace the air filter. c. Check the adjustment and the water supply. d. Make sure there is sufficient airspace surrounding the machine, (See "Model C602 Specifications" on page 1-4.) e. Correct the refrigerant charge. f. Replace the blower. g. Properly install the air deflector.
4. Head pressure is too low.	<ul style="list-style-type: none"> a. Refrigerant shortage. 	<ul style="list-style-type: none"> a. Repair leak and recharge.
5. Liquid line is hot.	<ul style="list-style-type: none"> a. Shortage of refrigerant. 	<ul style="list-style-type: none"> a. Repair leak and recharge.
6. Leaking door spout.	<ul style="list-style-type: none"> a. Improper lubrication. b. Worn or nicked O-ring. 	<ul style="list-style-type: none"> a. Lubricate according to instructions in the Operator's Manual. b. Replace the O-ring.
7. Excessive mix leakage through the rear of the machine into the drip pan.	<ul style="list-style-type: none"> a. Worn or missing driveshaft seal. b. Inadequate lubrication. c. Driveshaft rotates forward. 	<ul style="list-style-type: none"> a. If worn, nicked or missing, replace the driveshaft seal. b. Lubricate properly. c. Check gear alignment.

3

Problem	Cause	Remedy
8. Low overrun.	<ul style="list-style-type: none"> a. Bad scraper blades. b. Faulty air/mix pump components. c. Restricted air intake (air/mix pump). d. Incorrect syrup calibration (shake). e. Long ON cycles. f. Product flow is restricted in shake door. 	<ul style="list-style-type: none"> a. Replace scraper blades. b. Inspect air/mix pump components and replace those found faulty. c. Clear restriction. d. Calibrate syrup delivery for 1 oz. every 5 seconds. e. See problem 2. f. (See "Shake Dispensing Mechanism Troubleshooting" on page 3-9.)
9. Draw valve leaking.	<ul style="list-style-type: none"> a. Worn or missing draw valve O-rings. b. Inadequate lube on draw valve O-rings. c. Wrong type of lubricant being used. 	<ul style="list-style-type: none"> a. Replace regularly. b. Lubricate properly. c. Use proper lubricant. Example: Taylor Lube High Performance.
10. Product is not being fed into the freezing cylinder.	<ul style="list-style-type: none"> a. Inadequate mix in the hopper (Mix Out light is illuminated). b. Mix pump motor tripped reset. c. Air/mix pump incorrectly assembled. d. Mix feed tube not installed or incorrectly assembled. 	<ul style="list-style-type: none"> a. Fill hopper with mix. b. Press the RESET button. c. Assemble pump according to instructions in the Operator's Manual. d. Assemble and install the feed tube according to the instructions in the Operator's Manual.
11. No product being dispensed with draw valve open and machine in the Auto mode.	<ul style="list-style-type: none"> a. Plugged door spout. b. Beater rotating counterclockwise. c. Inadequate mix in the hopper (Mix Out light is illuminated). d. Pump motor tripped reset. e. Draw valve does not rise high enough to open the product port in the freezer door. 	<ul style="list-style-type: none"> a. Break down the machine and dislodge the door spout clog. b. Correct beater rotation to clockwise. c. Fill hopper with mix. d. Press the RESET button. e. (See "Shake Dispensing Mechanism Troubleshooting" on page 3-9.)
12. Product viscosity is too soft or thin.	<ul style="list-style-type: none"> a. Not enough airspace surrounding machine. b. Bad scraper blades. c. Dirty air-cooled condenser or air filter. d. Outdated mix. e. Refrigerant shortage. f. Product viscosity set too warm. g. Broken springs in the drive coupling (shake only). 	<ul style="list-style-type: none"> a. Allow 3 in. (76 mm) minimum clearance around machine. Allow 7-1/2 in. (190 mm) floor clearance. b. Replace scraper blades. c. Clean condenser, replace air filter. d. Use fresh mix. e. Locate leak and repair. f. Adjust product viscosity. g. Replace broken springs.

TROUBLESHOOTING

Problem	Cause	Remedy
13. Plugged door spout.	<ul style="list-style-type: none"> a. Poor scraping. b. Damaged draw valve O-rings. c. Damaged beater assembly. d. Worn rear shell bearing. 	<ul style="list-style-type: none"> a. Replace scraper blades. b. Replace O-rings. c. Inspect and replace if necessary. d. Inspect and replace if necessary.
14. No freezer operation when placing machine in any mode of operation.	<ul style="list-style-type: none"> a. Machine unplugged. b. Circuit breaker is turned off or fuse is blown. c. Power switch is in the OFF position. 	<ul style="list-style-type: none"> a. Plug in machine. b. Turn on circuit breaker or replace fuse. c. Place power switch in the ON position.
15. Product too stiff.	<ul style="list-style-type: none"> a. Product viscosity set too cold. b. Incorrectly assembled or malfunctioning air/mix pump. c. Improperly primed freezing cylinder. 	<ul style="list-style-type: none"> a. Adjust product viscosity. b. Reassemble pump or replace faulty components. c. Follow priming procedures according to the Operator's Manual.
16. Mix in the hopper is too cold.	<ul style="list-style-type: none"> a. Temperature is out of adjustment. 	<ul style="list-style-type: none"> a. Adjust hopper temperature.
17. Mix in the hopper is too warm.	<ul style="list-style-type: none"> a. Temperature is out of adjustment. b. Agitator not installed. c. Low glycol level. d. Mixture of glycol. 	<ul style="list-style-type: none"> a. Adjust hopper temperature. b. Install the agitator. c. Replenish the glycol. d. Replenish the glycol mixture (50% glycol, 50% distilled water).
18. Driveshaft is stuck in the gear box coupling.	<ul style="list-style-type: none"> a. Corners of the driveshaft, coupling, or both are rounded. b. Mix and lubricant are collected in the drive coupling. 	<ul style="list-style-type: none"> a. Replace the necessary component(s). Do not lubricate the end of the driveshaft. b. Brush clean the rear shell bearing area regularly.
19. Freezing cylinder walls are scored.	<ul style="list-style-type: none"> a. Bent beater assembly. b. Missing or worn front bearing. c. Scraper blades incorrectly installed. 	<ul style="list-style-type: none"> a. Replace beater. b. Install or replace front bearing. c. Install scraper blades over the appropriate securing pin on the beater assembly.
20. Although freezer was brush-cleaned, all four LEDs are flashing.	<ul style="list-style-type: none"> a. Power switch was not in the OFF position for a minimum of 5 minutes. 	<ul style="list-style-type: none"> a. When the Clean Manual and H.T. Cycle LEDs stop flashing, the freezer will be unlocked.
21. Product is popping when drawn.	<ul style="list-style-type: none"> a. Draw rate set too fast. b. Pump is assembled/lubed incorrectly. c. Faulty component in mix pump. d. Freezer has been turned on and off several times. 	<ul style="list-style-type: none"> a. Set the draw rate at 5 oz. to 7-1/2 oz. (142 g to 213 g) of product per 10 seconds. b. Assemble pump according to instructions in the Operator's Manual. c. Inspect/replace faulty pump components. d. Place the machine in the OFF position only when necessary.

Problem	Cause	Remedy
22. Freezer shuts off and produces a fault tone.	<ul style="list-style-type: none"> a. Fault alert. b. Insufficient air space. 	<ul style="list-style-type: none"> a. Check the fault screen in the Manager menu. b. Provide 3 in. (76 mm) air space around sides.
23. Syrup flows constantly or not at all (difficult calibration).	<ul style="list-style-type: none"> a. Clogged syrup lines. 	<ul style="list-style-type: none"> a. Flush syrup lines with warm water weekly.
24. Mix entering the syrup line.	<ul style="list-style-type: none"> a. Defective duckbill valve in the syrup fitting b. An empty syrup line is attached to the freezer door. 	<ul style="list-style-type: none"> a. Replace the duckbill valve. b. Remove the syrup line from the door when the line is not in use. Install a hole plug in the freezer door.
25. Soft lock.	<ul style="list-style-type: none"> a. No heat cycle tried. 	<ul style="list-style-type: none"> a. Press the Heat Cycle key to place the freezer in the heat treatment cycle, or select the Wash key and brush-clean the freezer.
26. When the Auto key is selected the freezer goes into Standby mode.	<ul style="list-style-type: none"> a. Mix-out condition. b. Freezer lock condition. 	<ul style="list-style-type: none"> a. Add mix. b. Check display screen for instructions.
27. Machine changes modes or shuts itself off.	<ul style="list-style-type: none"> a. Faulty connections or components. b. Inadequate voltage supply to the Universal Control. 	<ul style="list-style-type: none"> a. Replace faulty components. b. Check/correct voltage supply to the control (4.75VDC to 5.75VDC).
28. Compressor On Too Long fault message.	<ul style="list-style-type: none"> a. Inadequate pump operation. b. Draw rate set too fast. c. Inadequate airflow. d. Faulty blower baffle. e. Inadequate AXV settings. 	<ul style="list-style-type: none"> a. Check pump operation. Assemble pump according to instructions in the Operator's Manual. b. Set the draw rate at 5 oz. to 7-1/2 oz. (142 g to 213 g) of product per 10 seconds. c. Provide 3 in. (76 mm) airspace around sides. d. Repair or replace blower baffle. e. Set AXV at proper setting. (See "Running Specifications" on page 2-2.)
29. Symbol selection is delayed.	<ul style="list-style-type: none"> a. Defective DEC plate. 	<ul style="list-style-type: none"> a. Replace DEC plate.
30. Erratic brush-clean countdown display.	<ul style="list-style-type: none"> a. The rectifier guard is not installed. 	<ul style="list-style-type: none"> a. Installed the guard to shield the interface board from electrical noise.

Air Mix Pump System Troubleshooting

Table 3-2

Problem	Cause	Remedy
1. Air/mix pump will not operate in the Auto mode when the draw valve is opened.	<ul style="list-style-type: none"> a. Pump drive is out on reset. b. Malfunctioning interface board. c. Faulty pump motor. d. Faulty connection or draw switch. 	<ul style="list-style-type: none"> a. Allow the machine to cool and press the RESET button. b. Replace interface board. c. Replace motor. d. Check connections or replace switch.
2. Piston travels back and forth, but the product is not being pumped.	<ul style="list-style-type: none"> a. Gasket was installed incorrectly, fits loosely, has holes, or was lubricated. b. O-rings are worn, torn, or fit too loosely. c. Piston and valve body cap must be assembled correctly and fit snugly in the pump cylinder. d. Missing or defective check ring. 	<ul style="list-style-type: none"> a. Inspect gasket. b. Inspect O-rings. c. Check the pump cylinder for proper assembly and position. d. Replace the check ring.
3. Excessive pump cylinder wear.	<ul style="list-style-type: none"> a. Inadequate or incorrect lubrication of the pump cylinder. b. Ball crank rotates clockwise. 	<ul style="list-style-type: none"> a. Lubricate properly. b. Rewire the ball crank rotation to rotate counterclockwise.
4. Too much pressure in the freezing cylinder.	<ul style="list-style-type: none"> a. Plugged relief hole in the feed tube. 	<ul style="list-style-type: none"> a. Clean the relief hole in the feed tube.
5. Not enough pressure in the freezing cylinder.	<ul style="list-style-type: none"> a. Weak, damaged or missing check ring. b. Malfunctioning draw switch. 	<ul style="list-style-type: none"> a. Replace or install the check ring. b. Reposition or replace the microswitch.
6. One pump cannot be assembled.	<ul style="list-style-type: none"> a. Soft serve and shake pump parts are mixed up. 	<ul style="list-style-type: none"> a. Consult the Operator's Manual for correct pump assembly combinations.

3

Peristaltic Syrup System Troubleshooting Guide

Table 3-3

Problem	Cause	Remedy
1. No syrup dispensed.	<ul style="list-style-type: none"> a. Air in the syrup line. b. The syrup dispensing rate is not properly calibrated. c. The syrup pump motor is not running. d. A peristaltic pump component is defective. e. Obstruction in the syrup line. f. Obstruction in syrup nose fitting. g. A valve was left in the door during the heat cycle. h. The pump motor is running in the wrong direction. i. Defective motor speed control. j. Loose wire connection. 	<ul style="list-style-type: none"> a. Prime the syrup line. b. Calibrate the syrup. c. Check for faulty connections or a defective motor. d. Inspect/replace defective peristaltic pump component. e. Clean or replace the syrup line. f. Clear the obstruction. g. Clean the syrup valve. h. Check/correct the pump motor wiring. i. Replace the motor speed control. j. Inspect/repair loose connection.
2. Syrup leaking at the valve.	<ul style="list-style-type: none"> a. Air in the syrup line. b. The duckbill valve is defective. c. The pump motor reverse time is set too low. d. The reverse relay does not reverse the pump motor rotation when the syrup flow is stopped. 	<ul style="list-style-type: none"> a. Prime the syrup line. b. Replace the duckbill valve. c. Adjust the pump motor reverse time in the Syrup Motor Setup menu. d. Check the syrup reverse relay voltage supply. (Relay is energized to reverse the pump motor rotation.)
3. Air is in the syrup line.	<ul style="list-style-type: none"> a. The syrup line is improperly primed. b. The pump tube fitting O-rings are defective or not lubricated. c. The pump motor reverse time is set too long. d. Air leak on the intake side of the syrup line/pick up tube. 	<ul style="list-style-type: none"> a. Re-prime the syrup line. b. Replace/lubricate pump tube O-rings. c. Adjust the pump motor reverse time in the Syrup Motor Setup menu. d. Check the line for air leaks and repair it.
4. Flavor carry-over.	<ul style="list-style-type: none"> a. There is air in the syrup line. b. The whitespot setting is incorrect. c. The pump motor reverse time is set too low. d. The reverse relay does not reverse the pump motor rotation when the syrup flow is stopped. e. The duckbill valve is defective. f. The draw solenoid does not keep the draw valve raised. 	<ul style="list-style-type: none"> a. Prime the syrup line. b. Adjust the whitespot setting in the Service Menu. Recommended setting: 0.1 sec. to 0.2 sec. for standard shakes and 0.4 sec. to 0.7 sec. for triple thick shakes. c. Adjust the pump motor reverse time in the Syrup Motor Setup menu. d. Check the syrup reverse relay voltage supply. (The relay is energized to reverse the pump motor rotation.) e. Replace the duckbill valve. f. (See "Shake Dispensing Mechanism Troubleshooting" on page 3-9.)

TROUBLESHOOTING

Problem	Cause	Remedy
5. Shake is not blended correctly.	<ul style="list-style-type: none"> a. The spinner height is set too low. b. Shake temperature is set too cold/is too thick. c. Syrup calibration is not in specification. 	<ul style="list-style-type: none"> a. Adjust to 1/32 in. (0.79 mm) inside the door spout. b. Correct the temperature of a finished chocolate shake: Standard shake = 24°F to 26°F (4.4°C to 3.3°C). Triple thick shake = 22.5°F (-5.8°C). c. Calibrate the syrup.
6. Unable to calibrate the syrup within specification.	<ul style="list-style-type: none"> a. The weekly syrup line cleaning was not performed. b. The pump tube is worn. c. There's an obstruction in the syrup line. d. The syrup is too cold. e. There is an air leak on the intake side of the syrup line/pick up tube. f. Incorrect syrup calibration setting. g. The syrup fills the cup too fast to accurately calibrate. 	<ul style="list-style-type: none"> a. Clean and sanitize the syrup lines. b. Replace the tube. c. Clean out and replace the line if necessary. d. Stage the syrups near the machine. e. Find the leak and repair/replace. f. Adjust the SYRUP CAL setting in the Service menu: 5.0 seconds for standard shakes and 7.0 seconds for triple thick shakes. g. Adjust the motor speed setting slower in the Syrup Motor Setup menu.
7. Mix backs up in the syrup line.	<ul style="list-style-type: none"> a. Syrup line and/or syrup container is empty. b. The duckbill valve in the syrup fitting is defective. c. An empty syrup line is attached to the freezer door. d. The shake temperature is too cold. 	<ul style="list-style-type: none"> a. Replace the syrup container and prime the syrup line. b. Replace the duckbill valve. c. Remove the syrup line from the door when the line is not in use. Install a hole plug in the freezer door. d. The correct temperature of a finished chocolate shake is 22.5°F (-5.8°C).

Shake Dispensing Mechanism Troubleshooting

Table 3-4

Problem	Cause	Remedy
1. Draw valve will not open.	<ul style="list-style-type: none"> a. Power switch is OFF. b. The solenoid bumper screw is disengaged. c. The draw valve is binding in the freezer door. d. The draw solenoid is adjusted too high. e. The solenoid fuse has blown. f. The draw solenoid plunger is worn. g. Loose wire connection. h. Defective rectifier board. i. The pull or hold circuit is faulty. j. Defective pull or hold relay. k. Defective solenoid. l. Defective interface board. m. Defective touch key on the DEC plate. 	<ul style="list-style-type: none"> a. Place the power switch in the ON position. b. Align the actuator plate and secure the bumper screw to the solenoid plunger. c. Replace defective component. d. Adjust the draw solenoid to the proper height. (See "Draw Solenoid (059462-CP)" on page 2-71.) e. Inspect/replace the 12A fuse located in the front control channel. f. Replace the solenoid. g. Check the circuit for power interruption and repair it. h. Replace the rectifier board. i. (See "Draw Solenoid Voltage VDC" on page 2-71.) j. Replace defective relay. k. Replace the solenoid. l. Replace the interface board. m. Replace the DEC plate.
2. Occasionally the draw valve does not open.	<ul style="list-style-type: none"> a. The dispensing mechanism is out of alignment. b. Improper lubrication of the draw valve. c. Incorrect O-rings installed on the draw valve. d. The draw valve is binding in the freezer door. 	<ul style="list-style-type: none"> a. Realign the dispensing mechanism. (See "Shake Dispensing Alignment Procedure" on page 2-73.) b. Lubricate according to instructions in the Operator's Manual. c. Install the correct O-rings. d. Replace defective component.
3. Draw valve opens momentarily.	<ul style="list-style-type: none"> a. The draw valve solenoid is adjusted too high. b. The portion control system is terminating the draw after 2 seconds. c. The draw safety time is set too low. d. Defective hold relay. e. Loose wire connection in the draw solenoid circuit. 	<ul style="list-style-type: none"> a. Adjust the draw solenoid to the proper height. (See "Solenoid Valve Height Position" on page 2-74.) b. (See "Shake Portion Control Troubleshooting" on page 3-11.) c. Adjust the draw safety time in the Service Menu. d. Replace the relay. e. Check the circuit for power interruption and repair it.
4. Draw valve does not fully open (long draw time).	<ul style="list-style-type: none"> a. The solenoid bumper screw is loose. b. The draw solenoid is adjusted too low. 	<ul style="list-style-type: none"> a. Align the actuator plate and secure the bumper screw to the solenoid plunger. b. Adjust the draw solenoid to the proper height. (See "Solenoid Valve Height Position" on page 2-74.)

TROUBLESHOOTING

Problem	Cause	Remedy
<p>5. Draw valve will not close.</p>	<p>a. The freezer door is improperly installed.</p> <p>b. Improper lubrication of draw valve.</p> <p>c. Improper O-rings installed on the draw valve.</p> <p>d. The dispensing mechanism is out of alignment.</p> <p>e. The draw valve is binding in the freezer door.</p> <p>f. The solenoid plunger is binding in the coil body.</p> <p>g. Draw solenoid is set too high.</p> <p>h. The driven spinner has disengaged from the spinner blade assembly.</p>	<p>a. Re-install the freezer door. Tighten the handscrews in a crisscross pattern.</p> <p>b. Lubricate according to instructions in the Operator's Manual.</p> <p>c. Install the correct O-rings (Part No. 020571-1, F treated).</p> <p>d. Re-align the dispensing mechanism. (See "Shake Dispensing Alignment Procedure" on page 2-73.)</p> <p>e. Replace the defective component.</p> <p>f. Replace the solenoid.</p> <p>g. (See "Solenoid Valve Height Position" on page 2-74.)</p> <p>h. Adjust the spinner coupling. (See "Spinner Motor Alignment Procedures" on page 2-75.)</p>

Shake Portion Control Troubleshooting

Table 3-5

Problem	Cause	Remedy
1. Under-fills the shake cup.	<ul style="list-style-type: none"> a. The fill level adjustment screw is set too low. b. The portion control sensor lens is dirty. c. The cup holder is not properly positioned to fill the center of the cup. d. The shake cup is moving downward as the cup fills with product. e. The syrup calibration is set too high. f. Loose wire connection. g. Defective pyrosensor. h. Defective pyrosensor board. i. Defective shake personality board. 	<ul style="list-style-type: none"> a. Adjust the fill level screw. b. Clean the lens. c. Position the cup holder properly on the sensor box. d. Place the cup with the cup lip resting on the holder clips. e. Calibrate the syrup. f. Check/repair loose connection in circuit. (See "Pyroelectric Sensor Troubleshooting" on page 3-12.) g. Inspect pyrosensor, replace if needed. (See "Pyroelectric Sensor Troubleshooting" on page 3-12.) h. Inspect pyrosensor board, replace if needed. (See "Pyroelectric Sensor Troubleshooting" on page 3-12.) i. Inspect shake personality board, replace if needed. (See "Pyroelectric Sensor Troubleshooting" on page 3-12.)
2. Over-fills the shake cup.	<ul style="list-style-type: none"> a. The fill level adjustment screw is set too high. b. The viscosity of the shake is too thick, causing the product to stack in the center of the cup. c. The syrup calibration is set too low. d. The portion control sensor lens is dirty. 	<ul style="list-style-type: none"> a. Adjust the fill level screw. b. Check that the product temperature and overrun are within specification. c. Calibrate the syrup. d. Clean the lens.

Pyroelectric Sensor Troubleshooting

Check the cables (059135 and X59268) to verify connection to the proper pins. Check resistance to verify a good connection. If the problem persists, check the seven points of connection between the pyroelectric sensor and the UVC input, as follows:

1. Sensor input connection (X59268) to Pyroelectric Board (X59073) J3
2. Pyroelectric Board (X59073) input to output circuitry
3. Pyroelectric Board (X59073) output J2 connection to Shake Personality Board (X59072) J3 (harness 059135)
4. Shake Personality Board (X59072) J3 to Shake Personality Board (X59072) J2
5. Shake Personality Board (X59072) J2 to Heat Treat Interface Board (X53451) J13
6. Heat Treat Interface Board (X53451) J13 to Heat Treat Interface Board (X53451) J2
7. Heat Treat Interface Board (X53451) J2 to UVC3 J10 (50 pin ribbon cable)

Perform the following steps to check the 059135 harness:

1. Disconnect the harness from the pyroelectric board J2, leaving it connected to the personality board J3.
2. Check for 12VDC across pins 1 (12VDC) and 5 (GND) at the J2 end (red and black wires). If not, check for 12VDC at the personality board between pins 2 (GND) and 4 (12VDC).
3. Once the above measurement is confirmed, make sure the harness is disconnected from the pyroelectric board, but connected to the personality board. Check for 5VDC between pins 5 and 2 at the pyroelectric end of the harness.

PERSONALITY BOARD - SHAKE

Shake Pyroelectric (Orange)

Wires		Pin
Black & Red	12 VDC - All Time	2 & 4
Black & Green	2.5 VDC - All Time	2 & 3
Black & White	↑ VDC Hot ↓ Cold	2 & 1

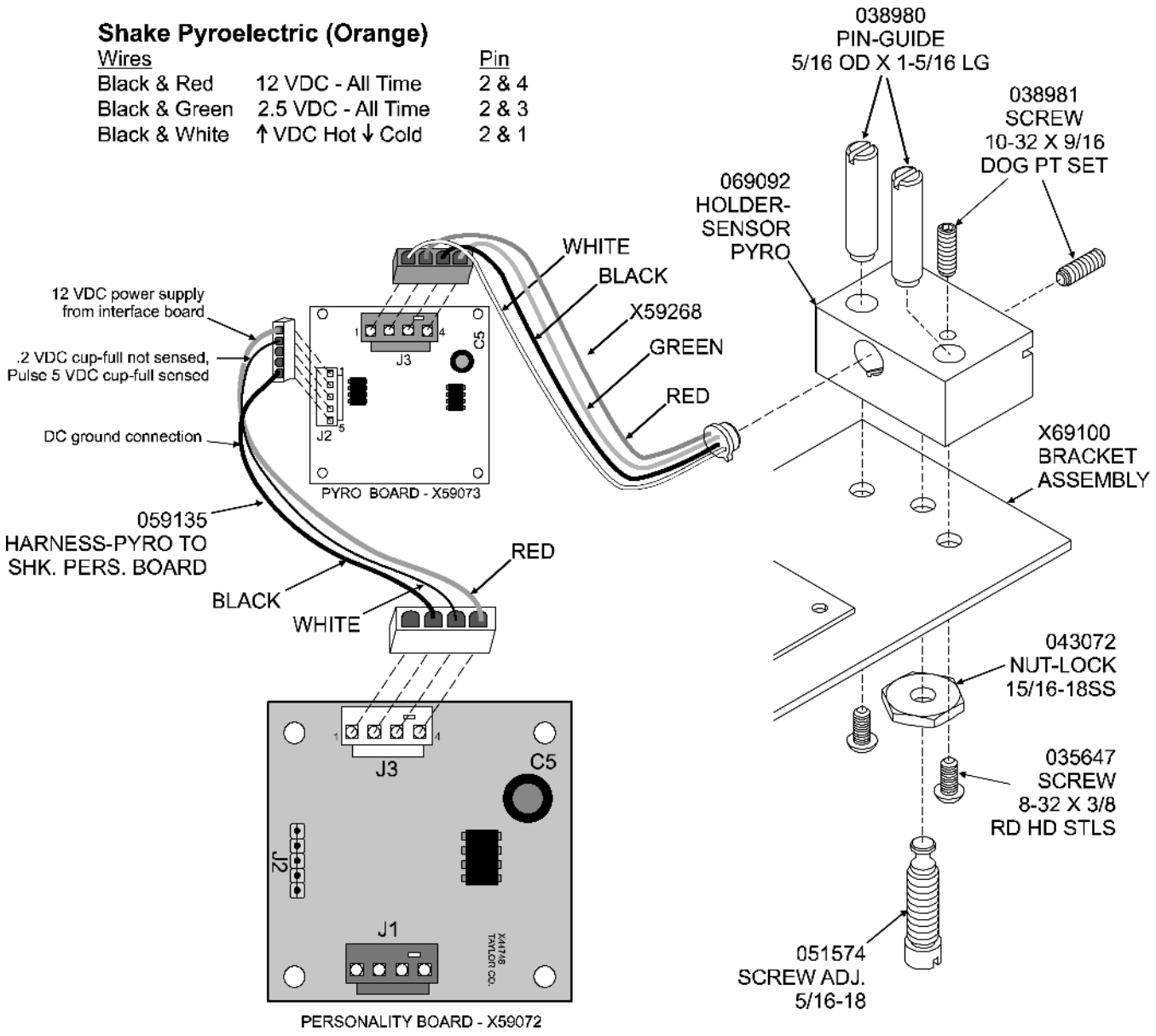

3

Figure 3-1

Bacteria Troubleshooting

Periodic product sampling is taken by a sanitarian. Bacteria counts should not exceed the following figures:

- Standard Plate Count (SPC) . . . 50,000
- Coliform 10

If the counts exceed the numbers listed, steps should be taken to locate the cause. Failure to solve the high counts will result in a product unsafe for consumption.

Educate the operator about how to prevent high bacteria counts.

Note: *High bacteria counts in soft serve yogurt is normal and necessary. Coliform, however, cannot be accepted in any product. The following information will help solve high coliform count problems.*

If sample results indicate a problem, one of these areas may be a source of contamination:

Table 3-6

Cause Of Contamination	Prevention
1. Human contamination.	<ul style="list-style-type: none"> a. Wash hands and arms past elbows. b. Wear rubber gloves if cuts or skin conditions exist. c. Wash hands periodically throughout the day.
2. Residue product deposits on mix contact surfaces (milkstone build-up).	<ul style="list-style-type: none"> a. Provide the proper brushes. b. Brush-clean all parts and components thoroughly. Ignoring this will allow formation of milkstone, a porous substance which will house bacteria and can lead to contamination of fresh mix.
3. Worn, damaged, or cracked parts.	<ul style="list-style-type: none"> a. Provide a food-grade lubricant (Example: Taylor Lube). b. Inspect O-rings for holes or tears. O-rings, seals and other wear items must be supplied by the freezer company to meet food industry standards. c. During the operating hours, periodically inspect the rear drip pan for excessive leakage.
4. Improper cleaning and sanitation procedures.	<ul style="list-style-type: none"> a. Follow cleaning procedures in the Operator's Manual. b. Provide the proper brushes, lubricants, and single-service towels. c. Store sanitizer in a cool, dry place. Use chemicals according to their labels. d. Use a few good employees to follow the cleaning procedure correctly and consistently. Allow the employees uninterrupted time to complete the cleaning procedure. e. Hold sanitizing solution in the hopper and the freezing cylinder for five minutes. f. Wash and sanitize the tube of lubricant. Always recap the tube after each use. g. Parts, components, and brushes should be air-dried overnight. Never store them in the cooler. h. Do not neglect daily cleaning practices: wipe the external areas of the freezer periodically throughout the day, remove the design caps and sanitize the area, check the drip trays and splash shield.

3

Cause Of Contamination	Prevention
5. Mix stored improperly	<ul style="list-style-type: none">a. Rotate stock to use older date code mix first. Shelf life of mix is normally 10 days.b. Mix must never be stacked outside or under direct sunlight while waiting to be placed in the cooler.c. Place the mix directly in the cooler. Always leave 1 in. (25 mm) between the mix and other products to allow air to circulate around the product.d. Mix must not remain at room temperature for long periods of time.e. Hopper storage must maintain a temperature of 40°F (4.4°C). Storage temperatures above 45°F (7.2°C) will allow cell division in as little as 1 hour.f. Once the mix is placed in the hopper, covers must be properly installed to maintain adequate refrigeration and to prevent airborne contaminants from entering the mix.

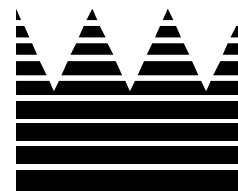

Section 4: Parts

- **Parts Warranty Explanation**
- **Main Exploded View**
- **Accessories**

Parts Warranty Explanation

- Class 103 Parts:** The warranty for new machine parts is one year from the original date of machine installation, with a replacement parts warranty of 3 months.
- Class 212 Parts:** The warranty for new machine parts is two years from the original date of machine installation, with a replacement parts warranty of 12 months.
- Class 512 Parts:** The warranty for new machine parts is five years from the original date of machine installation, with a replacement parts warranty of 12 months.
- Class 000 Parts:** Wear Items—no warranty.

CAUTION: Warranty is valid only if the parts are authorized Taylor parts, purchased from an authorized Taylor distributor, and the required service work is provided by a Taylor service technician.

Taylor reserves the right to deny warranty claims on machines or parts if unapproved parts or refrigerant were installed in the machine, system modifications were performed beyond factory recommendations, or it is determined that the failure was caused by neglect or abuse.

Main Exploded View

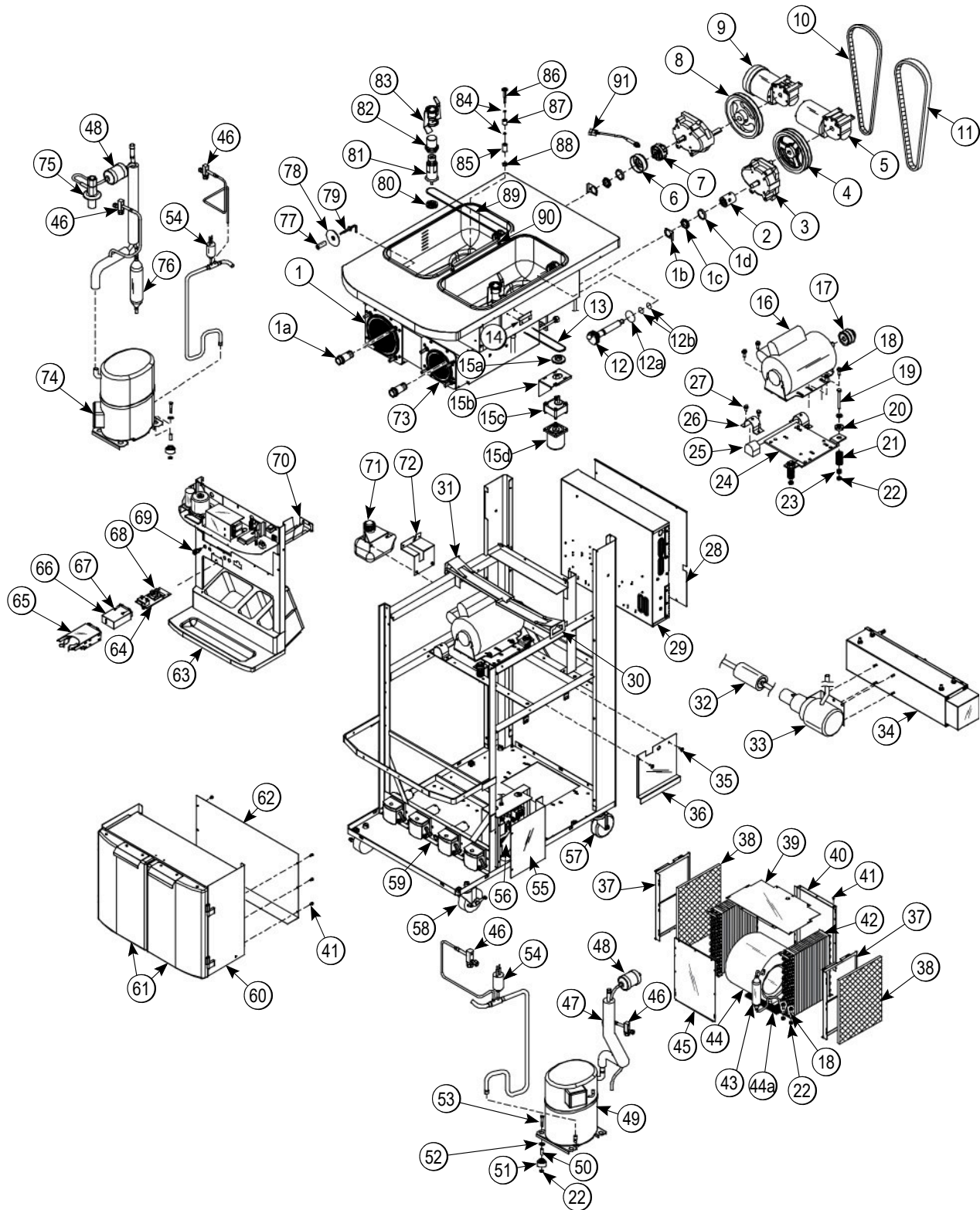

Figure 4-1

PARTS

Main Exploded View Parts List

Item	Description	Part No.
1	Shell A.-Insulated	X62257
1a	Bearing-Rear Shell	031324
1b	Washer-Bearing Lock	012864
1c	Nut-Bearing	028991
1d	Guide-Drip Seal	028992
2	Coupling-Drive 3/4 Hex	012721
3	Gear A.*Reducer 4.21:1	021286-SER
4	Pulley-2AK74-5/8	027822
5	Motor-Reducer 32 RPM	036955-34S
6	Deflector-Torque CPLG	054698
7	Coupling A.-Torque-SHK	X54722
8	Pulley-AK64-5/8	007538
9	Motor-Reducer 108RPM	044723-27S
10	Belt-AX31	041575
11	Belt-AX33	024396
12	Shaft A.-Drive-Mix Pump	X41947
12a	O-ring-1-3/4 OD X .139W	008904
12b	O-ring 1/2 ID X .139W	048632
13	Belt-Round 3/16 Green	062191-6
14	Clip-Panel*Right	056424
*	Clip-Panel*Left	056433
15	Motor A.-Agitator (Includes items 15a-15d)	X55971-27
15a	Pulley-AGT MTR-1.910 PD	042063
15b	Bracket-Motor-Agitator	056184
15c	Gear A.-Reducer- AGITAT	047988
15d	Motor-Agitator	047987-27
16	Motor-1.0 HP*Left	013102-33
	Motor-1.5 HP*Right	021522-33
17	Pulley-2AK22 x .625*Left	016403
	Pulley-AK25-5/8*Right	019153
18	Screw-5/16-18 X 7/8 HEX	017973

Item	Description	Part No.
19	Screw-5/16-18 X 3-1/4 STL	022678
	Screw-5/16-18 X 3 HEX	009497
20	Cap-Rubber Mount	011844
21	Spring-COMP .970 X .115	025707
22	Nut-5/16-18 MF Lock	017327
23	Grommet-7/16 X 5/16 Shock	016212
24	Hinge A.-Motor*Right	X25731
	Hinge A.-Motor*Left	X25736
25	Bushing-Rubber Mount	012258
26	Clamp-Mounting	012257
27	Screw-1/4-20X5/8 SERR.	017522
28	Cover-Control Box	066723
29	Control A. (Complete)	X55966-33
30	Guide A.-Drip Pan*Right	X55982
31	Guide A.-Drip Pan*Left	X55983
32	Filter A.-Glycol	X47323
33	Pump A.-Glycol	041785
34	Heater A.-Glycol 4500	X47395-SER
35	Screw-10-24X1/2 Taptite	002077
36	Guard-Cord	056792
37	Guide-Filter	053784
38	Filter-Air-18.00LX13.50HX.7	052779-3
39	Shroud-Top	056504
40	Shroud-Rear	055943
41	Screw-10X3/8TypeB-HWH	015582
42	Condenser-AC 12LX18H X 3.12T-5*Left/Shake	055813-1
	Condenser-AC 12L X 18H X 3.12T-5*Right/Soft Serve	055813-2
43	Receiver A.-REFRIG-R	X62629
44	Blower A.	X53725-27
44a	Screen-Blower	053729
45	Shroud-Front	055944

*Not Shown

Main Exploded View Parts List (Cont'd.)

Item	Description	Part No.
46	Valve-Access-1/4 MFL X 3/8	053565
47	Exchanger A-Heat Right	X62622
48	Dryer-Filter-HP62-3/8 X 1/4	048901
49	Compressor L63A113DBLA (Soft Serve)	048259-33H
50	Sleeve-Mounting-COMP.	039924
51	Grommet-Compressor MT	039923
52	Washer-5/16-Flat ZP Steel	000651
53	Screw-5/16-18X1-3/4 Hex	019691
54	Switch-Pressure 350 PSI	048231
55	Cover-Splice Box	066013
56	Box A.-Splice w/ LON	X69107-33
57	Caster-4" SWV 3/4-10 STM	044106
58	Caster-4" SWV 3/4-10 STM w/ Brake	046437
59	Pump A.-ULT. Syrup ROHS	X56015
60	Cabinet A.-ULT Syrup	X55984
61	Door A.-Cabinet	X58607-R
62	Panel-Syrup Panel-Back	056387
63	Panel A.-Front	X55981
64	Holder A.-25DCC PYR SNS	X69102
65	Holder-Cup-Shake-3.906	056008
66	Cover A.-25DCC PYR SNS	X69097
67	Screw-10-32 X 1/2 Truss HD	037734
68	PCB A.-CC-ROHS-PYRO	X69110-02S
69	Fitting-Panel MT QD .250 ID	056674
70	Guide A.-Drip Pan Center	X55972
71	Tank-Glycol 1.5qt.-PLAST	047314
72	Bracket-Tank-Glycol	047585
73	Stud-Nose Cone	055987
74	Compressor M63B203DBDB Shake	062274-33H
75	Valve-EXP-Auto-1/4S X 1/4	046365
76	Receiver A.-REFRIG-L-AC	X56124
77	Spacer-Probe *SQ Hole*	030966

Item	Description	Part No.
78	Disc-Probe *SQ Hole*	030965
79	Probe A.-Mix Low-HT	X42077
80	Pulley-AGT DR-1.910PDX5/16	036210
81	Housing A.-Agitator Long	X51661
	Housing A.-Agitator *Short	X51664
82	Cap-Magnet	044796-J
83	Agitator	036059
84	O-ring-1/2 OD X .070W	024278
85	Spacer-Probe-SQ Hole-7/8	041346
86	Probe A.-Mix Out-SQ Hole	X41348
87	Spacer-Probe-Round	041347
88	Nut-10-32 Hex	005598
89	Belt-RD 3/16 Green	062191-7
90	Pin-Retaining-Hopper CVR	043934
91	Sensor A.-EVC	X44951

*Not Shown

Operator Parts Identification

4

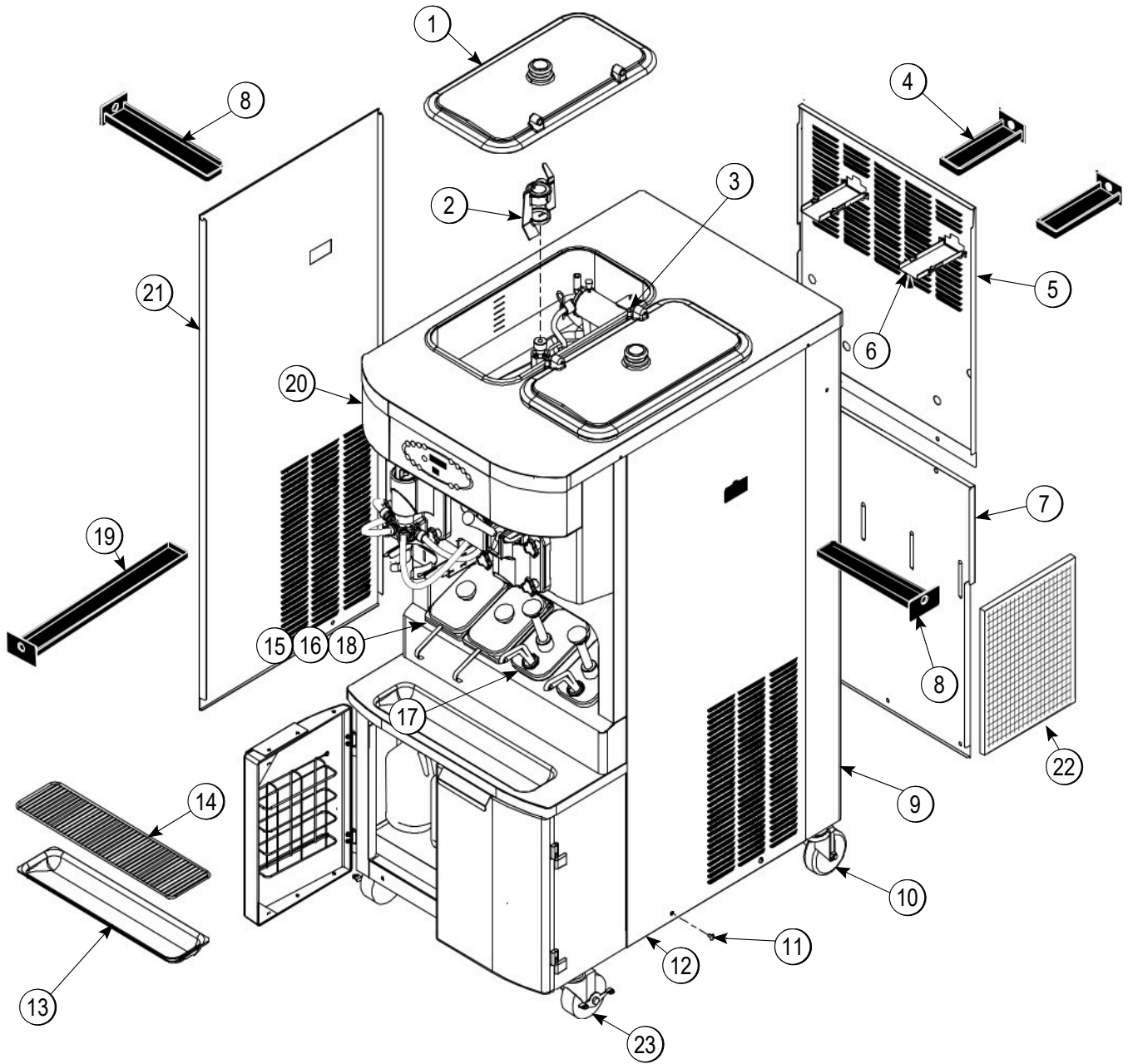

Figure 4-2

Operator Parts Identification

Item	Description	Part No.
1	Cover-Hopper*Black*	053809-1
2	Agitator Assembly	X44797
3	Pin-Retaining Hopper Cover	043934
4	Pan-Drip-Rear 8-3/4" L (22.2 cm)	X56003
5	Panel-Rear-Upper	066724
6	Guide A.-Drip Pan Mix Pump	X48228
7	Panel-Rear-Lower	055959
8	Pan-Drip-Side 12-3/4" L (32.4 cm)	X56005
9	Trim-Corner-Rear Right Side	056692
	Trim-Corner-Rear Left Side	056693
10	Caster-4"	044106
11	Screw-1/4 - 20 x 3/8	011694

Item	Description	Part No.
12	Panel-Side Right	055950
13	Tray-Drip	033812
14	Shield-Splash	033813
*15	Lid-Syrup Jar	042706
*16	Jar-Syrup - Plastic Shallow	036573
*17	Jar-Syrup - Stainless Shallow	036574
*18	Ladle-1 oz. (30 ml.)	033637-1
19	Pan-Drip 19-3/4" Long (50.2 cm)	035034
20	Plate-Dec.	056131
21	Panel-Side Left	055957
22	Filter-Air 18.0 L x 13.5 H x .70 W	052779-3
23	Caster-4" Swv 3/4-10 Stem W/ Brake	046437

* For machines manufactured prior to serial number M1080000.

4

Front View

4

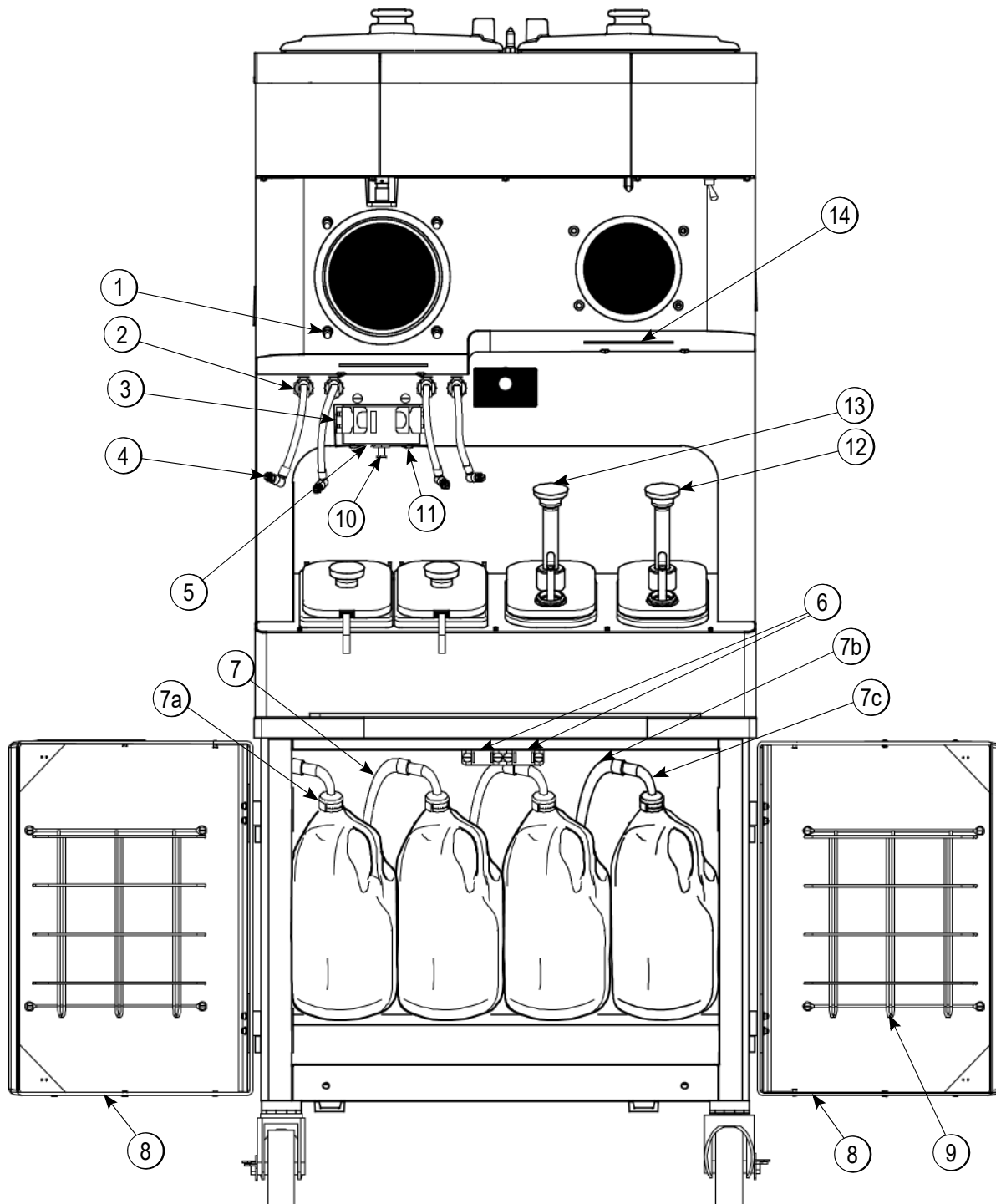

Figure 4-3

Front View

Item	Description	Part No.
1	Stud-Nose Cone	055987
2	Fitting-Panel Mount QD	056674
3	Clip-Spring Cup Holder	068394
4	Line A.-Syrup Door TTS (Thick Viscosity Syrup)	X56652
	Line A.-Syrup Door (Thin Syrup)	X59304
5	Shield-Pyroelectric Sensor	064942
†6	Magnet-Catch Assy.	016121
7	Fitting A.-Syrup Jug	X53353-BLU X53353-BRN X53353-RED X53353-WHT
***7	Line A.-Syrup (for bag syrup system)	X58450
7a	Cap-Ultimate Syrup	053040-BLU 053040-BRN 053040-RED 053040-WHT

Item	Description	Part No.
7b	Hose-Beverage	053052-36
7c	Tube A.-Syrup Pick Up	X53175
*7d	Ferrule-.625 ID	053036
*7e	Fitting-Peristaltic Pump	054526
*7f	O-ring 1/2 OD X .070 W	024278
8	Door A.-Cabinet (Left)	X58607-L
	Door A.-Cabinet (Right)	X58607-R
9	Basket-Door-Wire	059144
10	Screw-Adjustment	051574
11	Holder-Cup Shake	056008
**12	Pump A.-Syrup- Heated (Chocolate)	X53800-BRN
**13	Pump A.-Syrup- Heated (Caramel)	X53800-TAN
14	Gasket-Drip Lip	036435

* Not Shown

** For machines manufactured prior to serial number M1080000.

*** Bag Syrup System (Not Shown)

† Prior to Serial No. K4091994, use 058630 Latch-Door-Magnetic.

Beater Door Assembly—Shake Side

4

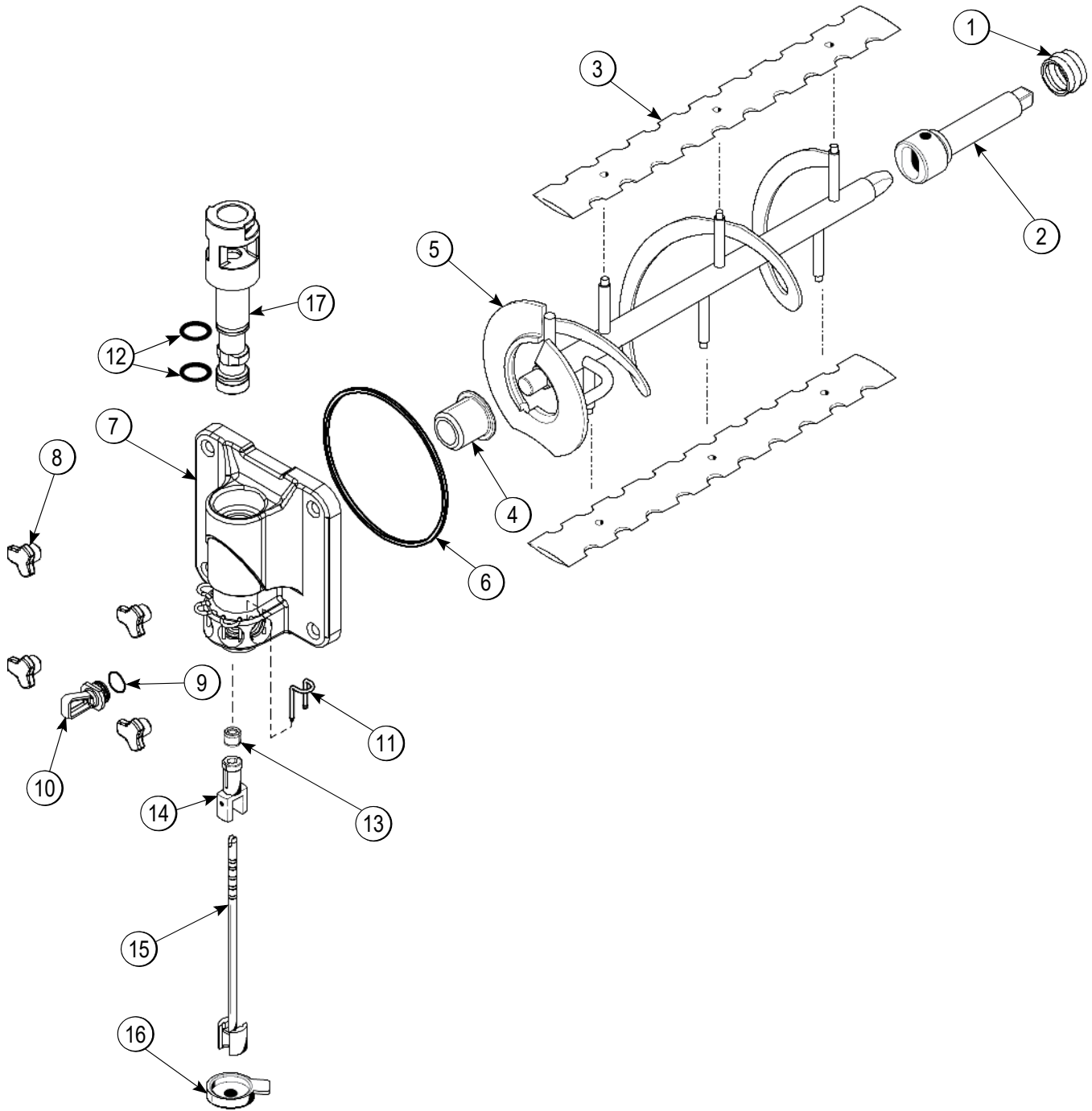

Figure 4-4

Item	Description	Part No.
1	Seal-Drive Shaft	032560
2	Shaft-Beater 7 Qt. Fluted Blade	050985
3	Blade-Scraper-16"	041103
4	Bearing-Door Front 1.390 OD	055605
5	Beater A.-7 Qt. Fluted Blade	X50958
6	O-ring 6" - Freezer Door	033493
7	Door A.-Shake Side	X55825SER2
8	Nut-Stud-Short	055989
9	O-ring -Syrup Port 11mm ID x 2mm Green	053890

Item	Description	Part No.
10	Plug-Syrup Port	053867
11	Retainer-Syrup Valve	054554
12	O-ring - 1-1/16 OD x .139 W (Draw Valve)	020571
13	Seal-Spinner Shaft	036053
14	Spinner	034054
15	Blade A.-Spinner Aluminum-HT	X59331
16	Cap-Restrictor	033107
17	Valve A.-Draw	059000

Beater Door Assembly—Soft Serve Side

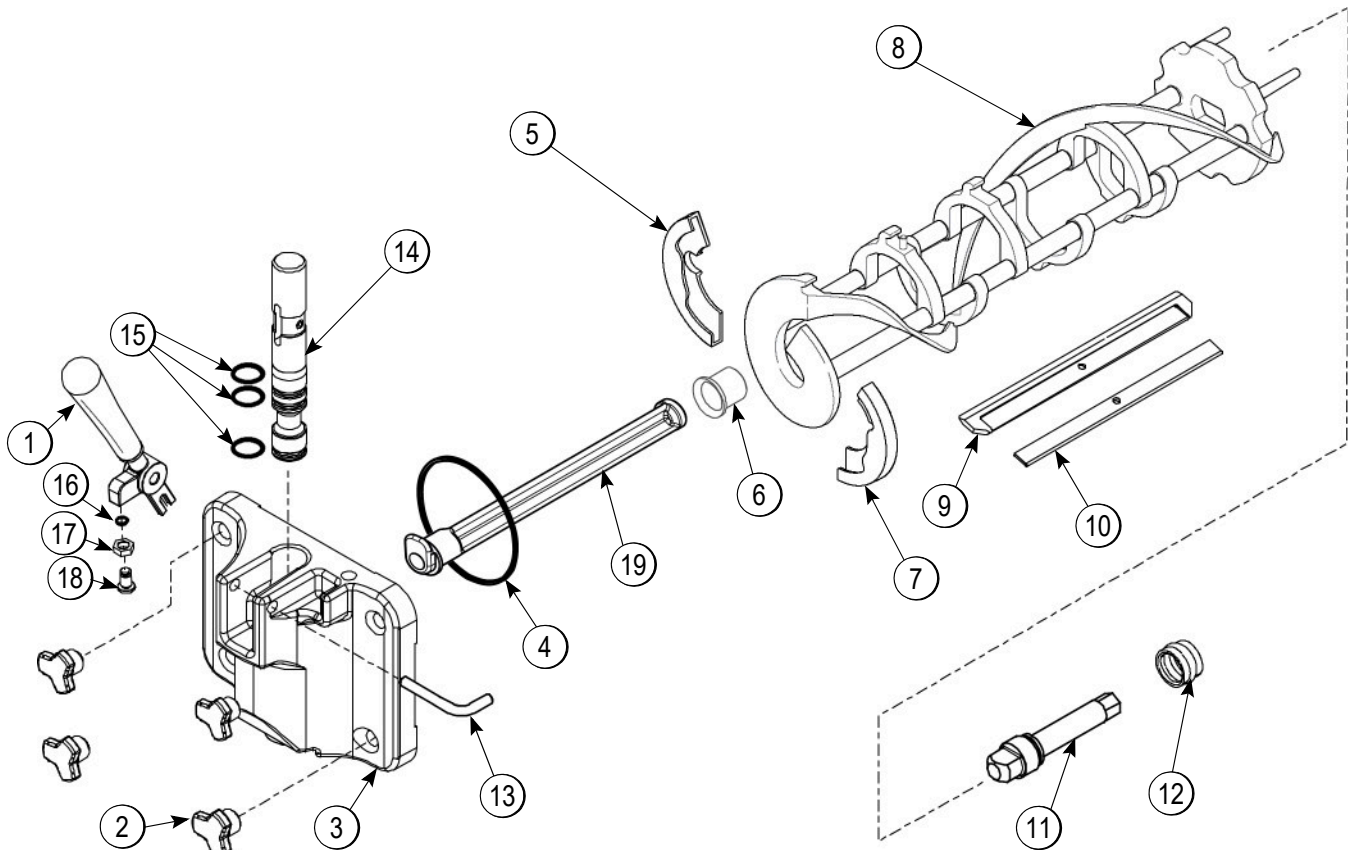

Figure 4-5

Item	Description	Part No.
1	Handle A.-Draw	X56421-1
2	Stud Nut	055989
3	Door A.	X87683-SER1
4	Gasket (Freezer Door)	048926
5	Shoe-Front Helix-Rear	050346
6	Bearing-Front	050348
7	Shoe-Front Helix- Front	050347
8	Beater Assembly	X46231
9	Blade-Scraper	046235

Item	Description	Part No.
10	Clip-Scraper Blade	046236
11	Drive Shaft	032564
12	Seal-Drive Shaft	032560
13	Pin-Pivot	055819
14	Valve A.-Draw	X55820
15	O-ring (Draw Valve)	014402
16	O-ring	015872
17	Nut-Jam SS	029639
18	Screw-Adjustment	056332
19	Baffle -Threadless Molded	087708

Pump A.—Mix Simplified Shake - X57028-XX

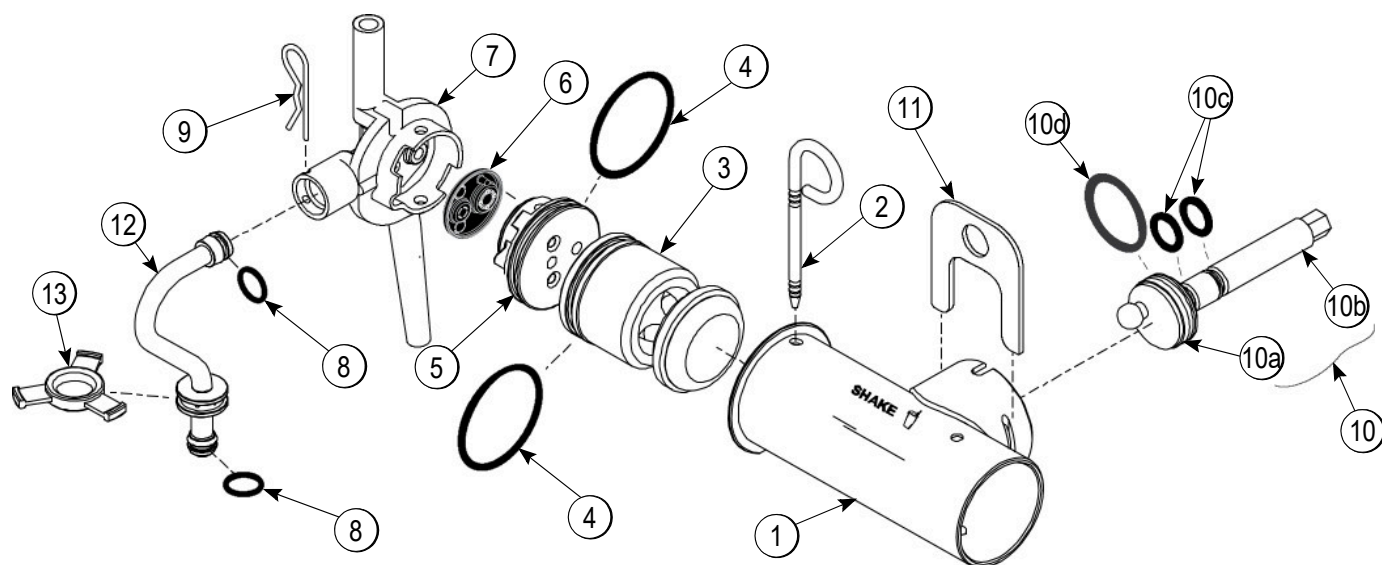

Figure 4-6

Item	Description	Part No.
1-7	Pump A.-Mix Simplified Shake	X57028-XX
1	Cylinder-Pump-Hopper- Shake	057944
2	Pin A.-Retaining	X55450
3	Piston	053526
4	O-ring 2-1/8" OD- Red	020051
5	Cap-Valve	056873-XX
6	Gasket-Simplified Pump Valve	086097
7	Adaptor-Mix Inlet Shake-Blue	054944
8	O-ring-11/16 OD - Red	016132

Item	Description	Part No.
9	Pin-Cotter	044731
10	Shaft A.-Drive Mix Pump	X41947
10a	Crank-Drive	039235
10b	Shaft-Drive	041948
10c	O-ring-Drive Shaft	048632
10d	O-ring 1-3/4	008904
11	Clip-Mix Pump Retainer	044641
12	Tube A.-Feed-Hopper Shake	X55973
13	Ring-Check.120 OD	056524

Pump A.—Mix Simplified Soft Serve - X57029-XX

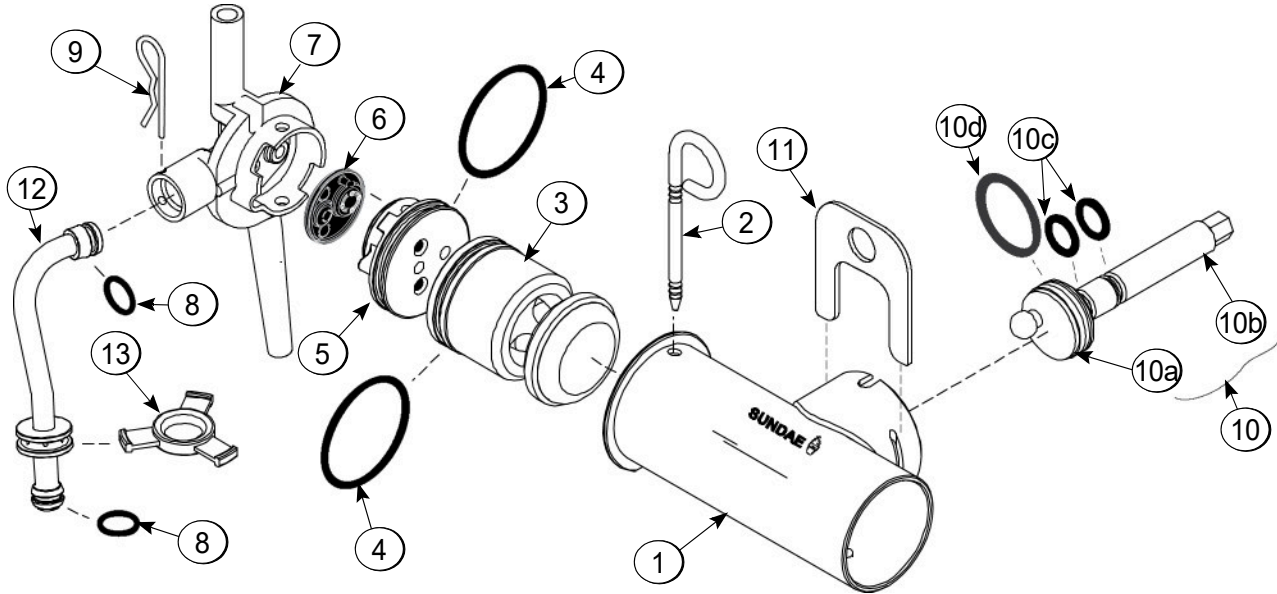

Figure 4-7

Item	Description	Part No.
1-7	Pump A.-Mix Simplified S.S.	X57029-XX
1	Cylinder-Pump-Hopper-Soft Srv	057943
2	Pin A.-Retaining	X55450
3	Piston	053526
4	O-ring 2-1/8" OD - Red	020051
5	Cap-Valve	056874-XX
6	Gasket-Simplified Pump Valve	086097
7	Adaptor-Mix Inlet Soft Srv-Red	054825
8	O-ring - 11/16 OD - Red	016132

Item	Description	Part No.
9	Pin-Cotter	044731
10	Shaft A.-Drive-Mix Pump - Hopper	X41947
10a	Crank-Drive	039235
10b	Shaft-Drive	041948
10c	O-ring - Drive Shaft	048632
10d	O-ring 1-3/4	008904
11	Clip-Mix Pump Retainer	044641
12	Tube A.-Feed Hopper - Soft Srv	X55974
13	Ring-Check.120 OD	056524

Brush Identification

Note: For proper brush cleaning of the adapter, cap, feed tube, and orifice, refer to the following illustration which indicates proper brush usage.

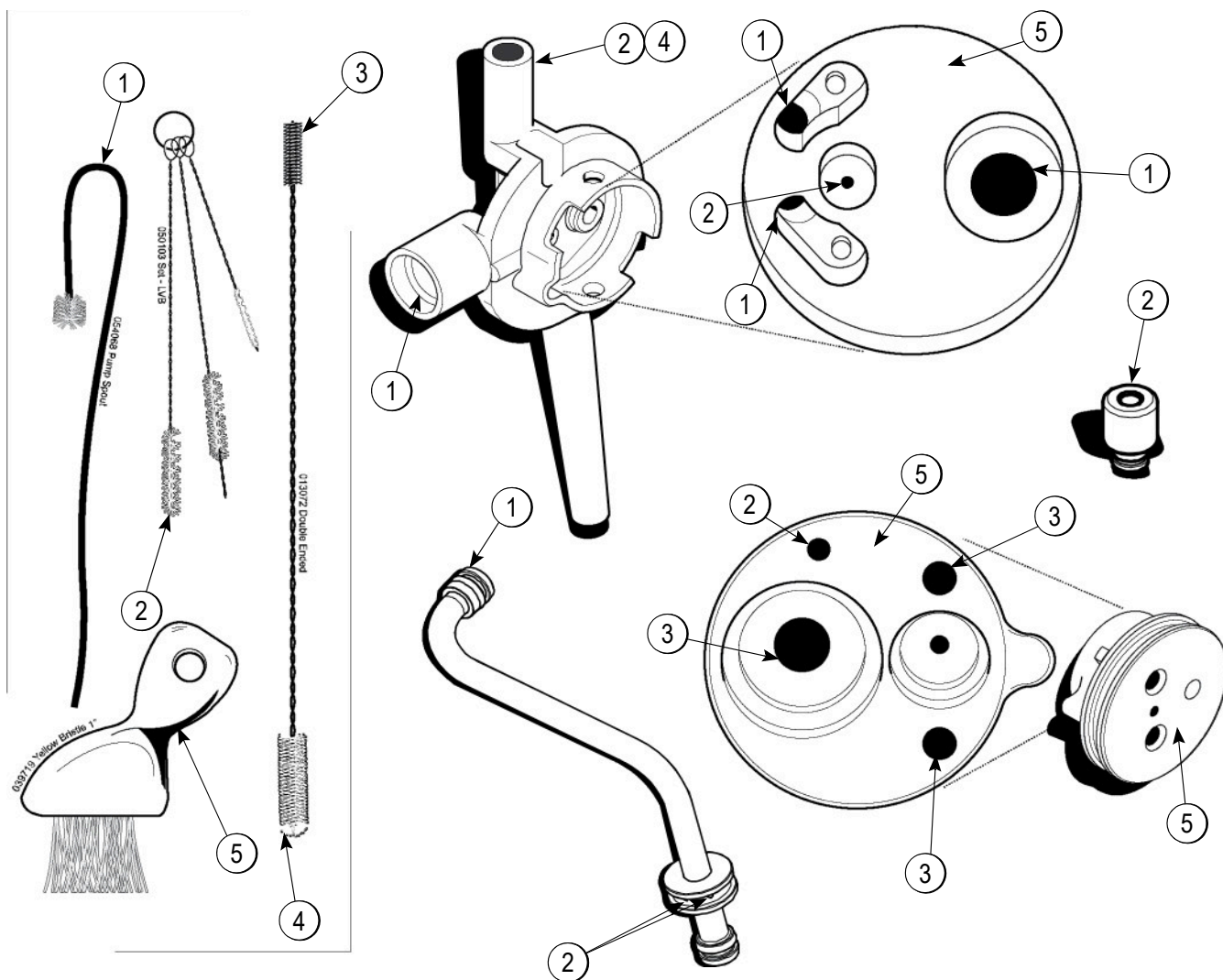
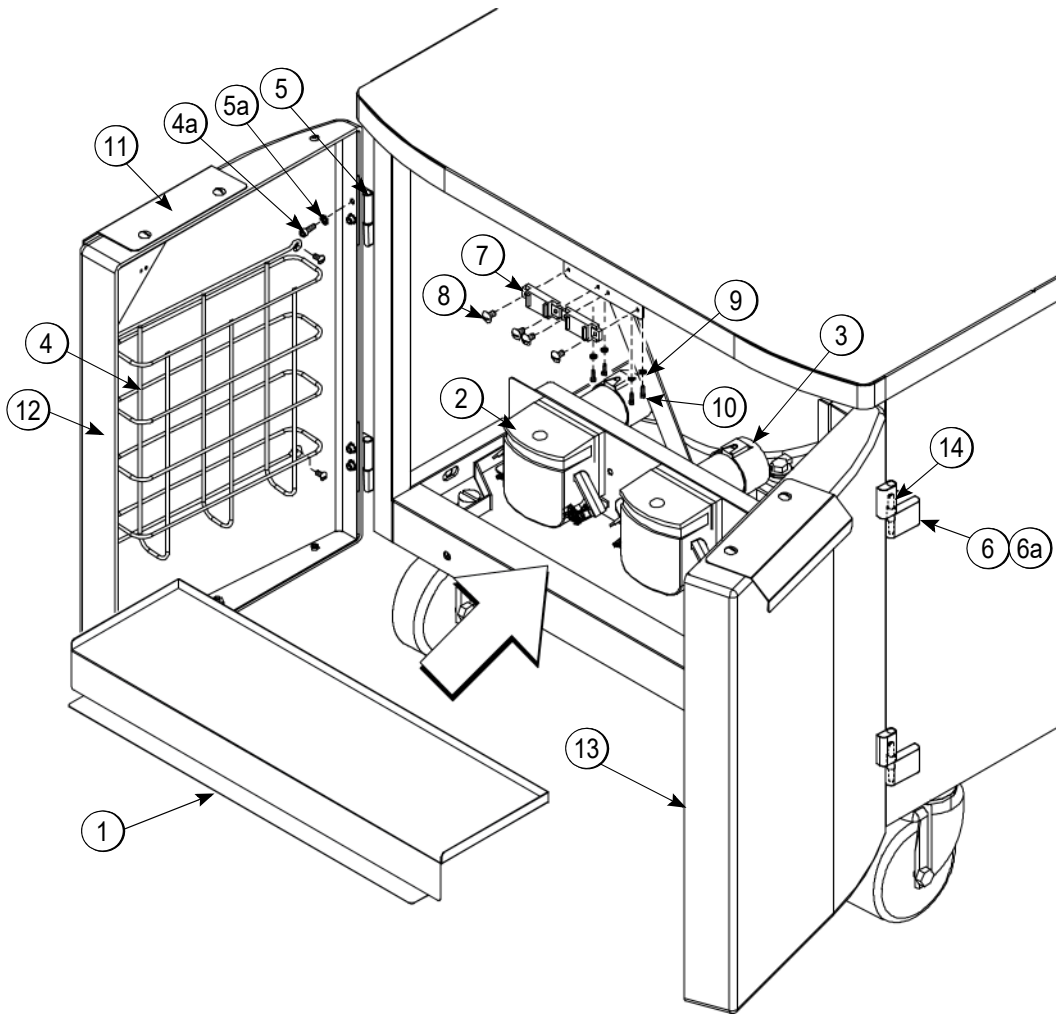

Figure 4-8

Item	Description	Part No.
1	White Bristle - 1/2" x 1/2"	054068
2	White Bristle - 3/16" x 1"	050103
3	Black Bristle - 1/4" x 1-1/4"	013072

Item	Description	Part No.
4	White Bristle - 1/2" x 1"	013072
5	White Bristle - 3" x 1/2"	039719

Syrup Cabinet View



4

Figure 4-9

Item	Description	Part No.
1	Shelf-Syrup	056016
2	Pump-Peristaltic	052916
3	Motor-Gear 161 RPM	058725
4	Basket-Door-Wire	059144
4a	Screw 10-32 X 3/8 SLTD RD	006749
5	Block-Hinge	058613
5a	Screw 8-32 X 1/2 Socket HD	058322
6	Block-Hinge	058614

Item	Description	Part No.
6a	Screw 8-32 x 5/16 SLTD RD	017552
*7	Magnet-Catch ASSY.	016121
8	Screw-6-32 X 3/8 SLT Binder	002201
9	Washer #4 EXT. Tooth Lock	043075
10	Screw 4-40 X 3/8 Socket	058317
11	Handle-Door Short	065933
12	Door A.-Cabinet (Left)	X58607-L
13	Door A.-Cabinet (Right)	X58607-R

*Prior to S/N K4091994, use 058630 Latch-Door-Magnetic.

Syrup Pump and Tubes

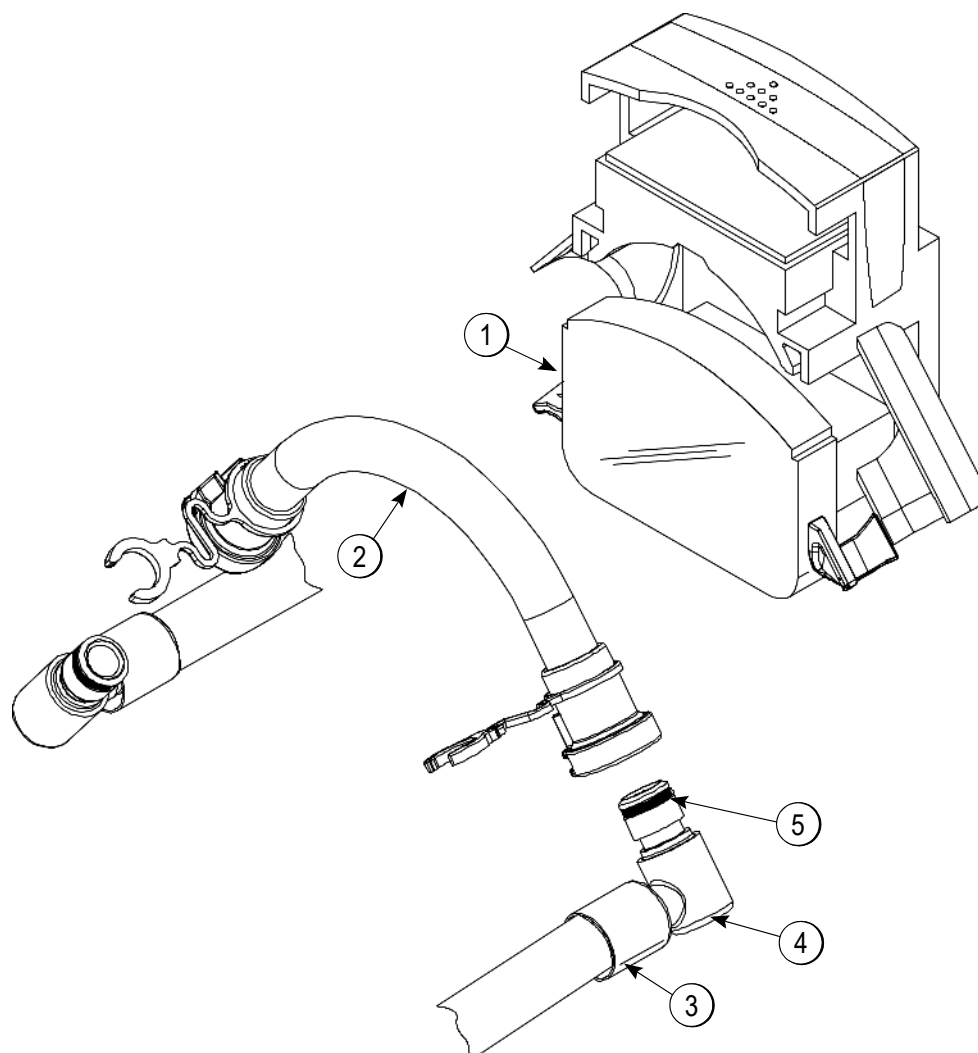

4

Figure 4-10

Item	Description	Part No.
1	Pump-Peristaltic	052916
2	Kit A.-Peristaltic Pump Tube	X54978
3	Ferrule- .625 ID	053036

Item	Description	Part No.
4	Fitting-Peristaltic Pump	054526
5	O-ring 1/2 OD x .070	024278
*	Line A.-Syrup	X62426-8

*Not Shown

X56652 Line A.—Syrup Door - Thick Shake Syrup

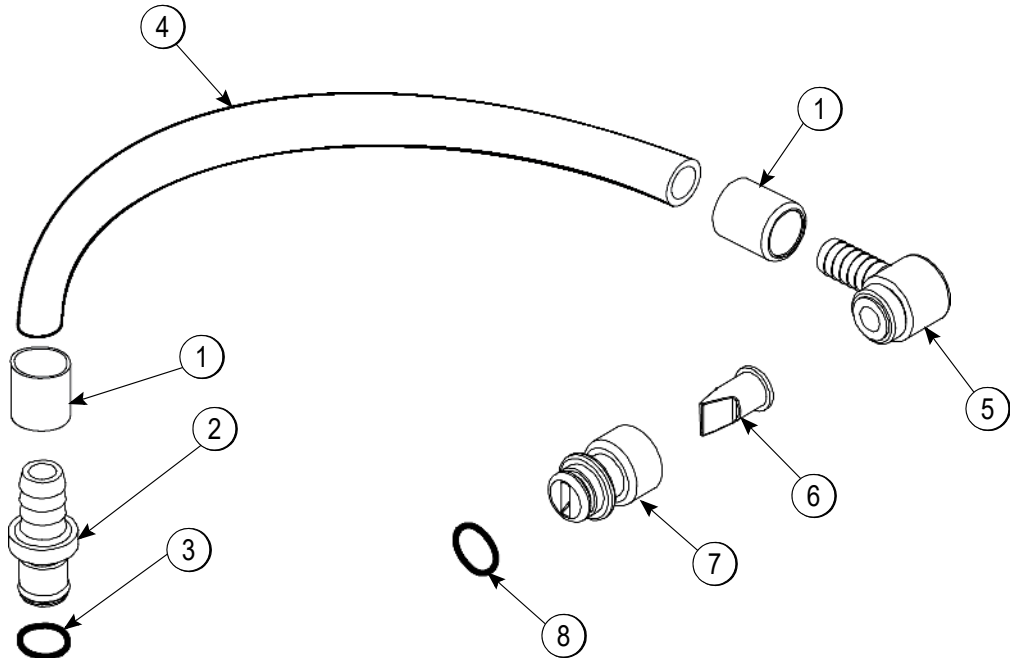

Figure 4-11

Item	Description	Part No.
1	Ferrule-.625 ID	053036
2	Insert-QD-CPC-3/8 Barb Plastic	056675
3	O-ring	500205
4	Hose-Beverage	053052-9
5	Fitting-Syrup Elbow	056651

Item	Description	Part No.
6	Valve-Check Duckbill	500598
7	Fitting-Syrup Nose (Large Slot)	056650
8	O-ring-11 mm Green (Syrup Hole Plug)	053890

X59304 Line A.—Syrup Door - Thin Viscosity Syrup

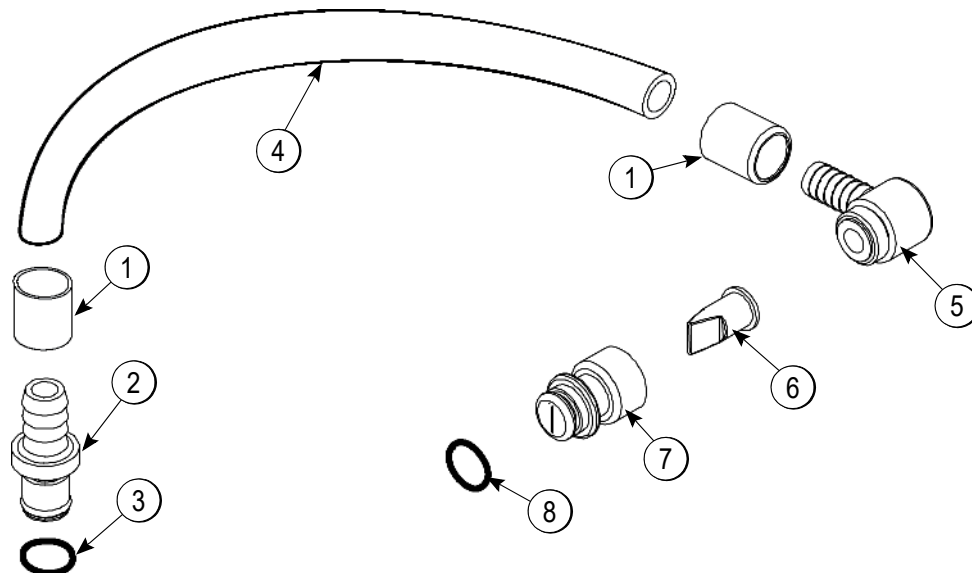

Figure 4-12

Item	Description	Part No.
1	Ferrule-.650 ID	029834
2	Insert-QD-CPC 3/8 Barb Plastic	056675
3	O-ring	500205
4	Tube-Vinyl	500038-9
5	Fitting-Syrup Elbow	056651

Item	Description	Part No.
6	Valve-Check Duckbill	500598
7	Fitting-Syrup Nose (Small Slot)	056649
8	O-ring-11 mm Green (Syrup Hole Plug)	053890

X58450 Line A.—Syrup (Syrup-In-Bag Option)

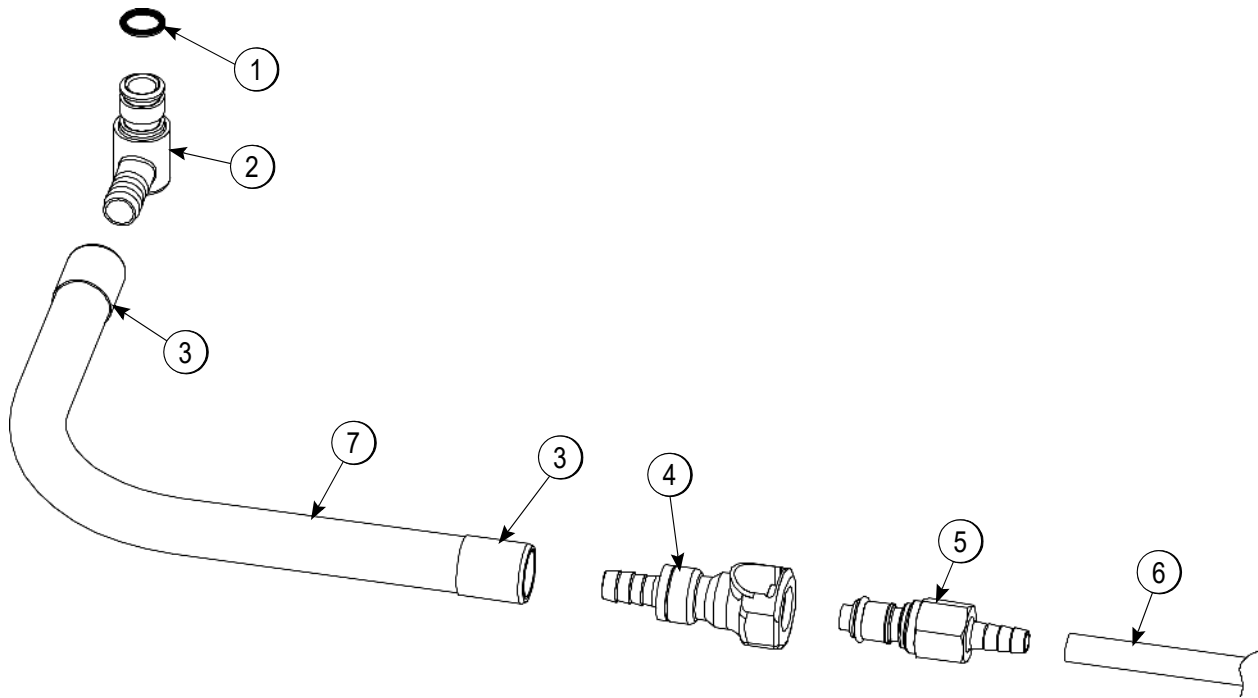

Figure 4-13

Item	Description	Part No.
1	O-ring-1/2 OD x .070	024278
2	Fitting-Male Peristaltic Pump	054526
3	Ferrule-.625 ID NP Brass	053036
4	Coupling-QD Female 3/8 Barb	058451

Item	Description	Part No.
5	Coupling-QD Male 1/4 Barb	058452
6	Tube-Vinyl 3/16 ID x 1/16 Wall	R30314
7	Hose-Beverage 3/8 ID	053052-36

Channel-Control

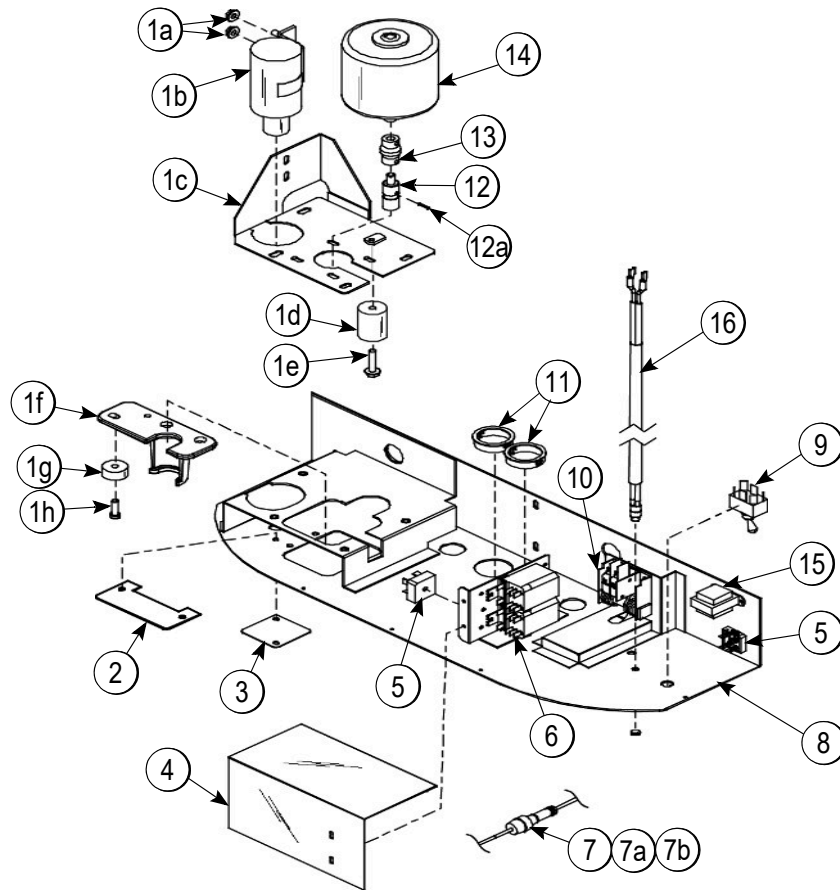

Figure 4-14

PARTS

Item	Description	Part No.
1	Valve A.-Dispensing (Includes Items 1a-1h)	X62343
1a	Nut-1/4-20 Whiz Flange	017523
1b	Solenoid-Draw Valve-SH	059462-CP
1c	Mount A.-Spinner	X62342
1d	Guide-Actuator	062199
1e	Screw-1/4-20X1-1/4 SERR.	024351
1f	Bracket-Coupling-ACT.	056620
1g	Bumper-Recessed	057910
1h	Screw-1/4-20X3/4 Low Head	057911
2	Grommet-Valve-Spinner	062240
3	Cover-Adjust-Actuator	062270
4	Guard-Rectifier	059482
5	IC-15A-Bridge-1000V	040172-102
6	Relay-DPDT 20A-12VDC	077164-02
7	Harness-Wire-Control- High-Volt	059476

Item	Description	Part No.
7a	FUSE-12 A-Buss BK/ABC-12-R (K6065606 and After)	064536
7b	Holder-Fuse-Inline-Type HRK (K6065606 and After)	064538
8	Channel A.-Control	X62345
9	Switch-Toggle-DPDT*VDE	054809
10	Switch A.-Draw	X33322-SP1
11	Bushing-Snap 1-5/16IDX1-1/2	017008
12	Coupling A.-Drive-Spinner	X20329
12a	Pin-Roll-3/32X9/16 Steel	015971
13	Coupling-Flexible	020108
14	Motor A.-Spinner w/ Plug	X35584SER2
15	Trans.-24V PR1/24V SEC 10V	030132-27
16	Jack A.-Flavor Burst	X56353

***Control Assembly—X55966-33**

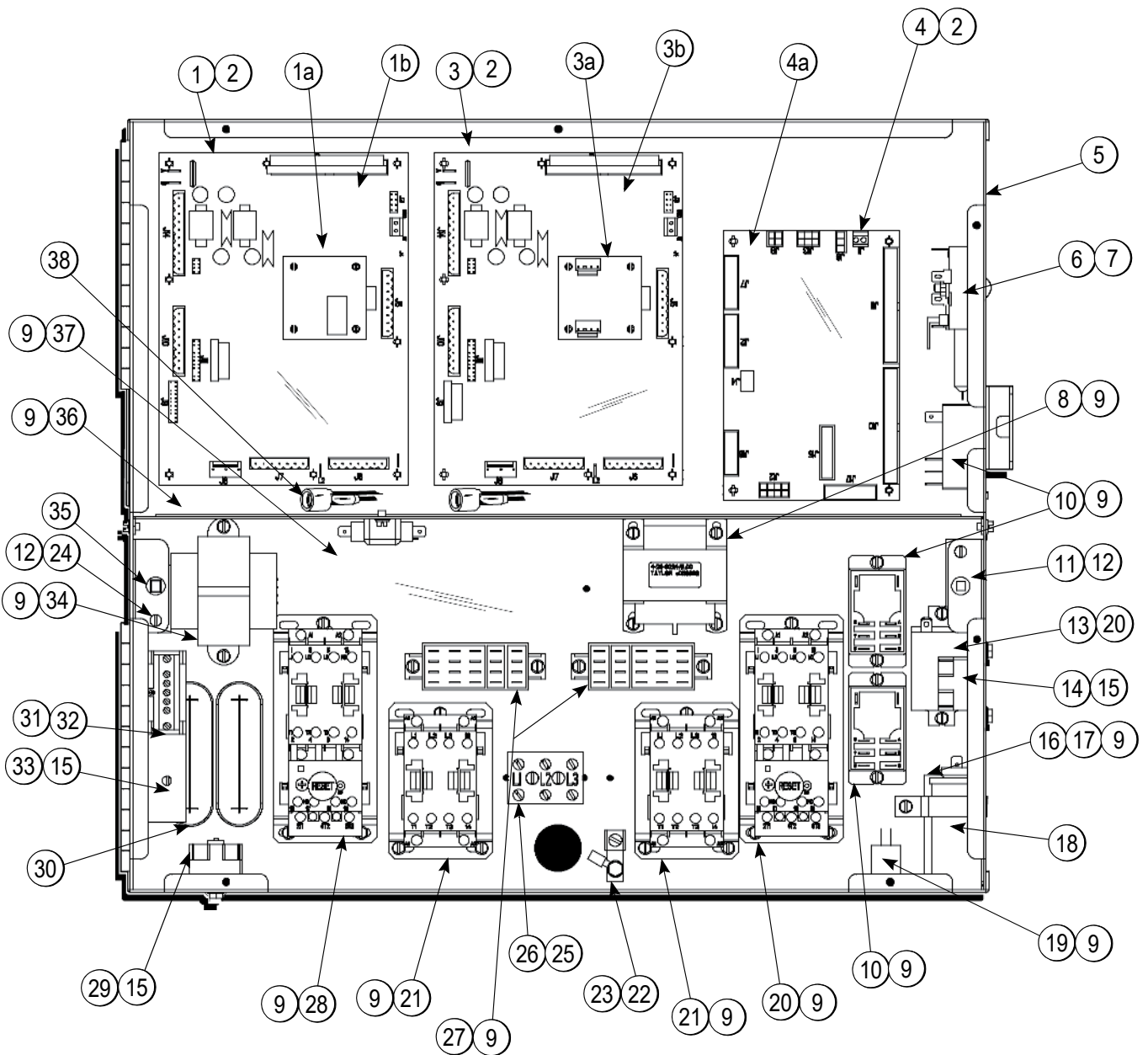

4

Figure 4-15

PARTS

Control Assembly—X55966-33

Item	Description	Part No.
1	PCB A.-Interface-HT-SS-UK	X53453-SER
1a	PCB A.-Personality HT SS	X46904-SER
1b	PCB A.-HT Interface Base	X53451-SER
2	Standoff-Nylon-Snap-1/2L	053413
3	PCB A.-Interface-HT-SH	X59076-SER
3a	PCB A.-Personality	X59072-SER
3b	PCB A.-HT Interface Base	X53451-SER
4	PCB A.-Control UVC4	X69068-SER
4a	Control-UVC4	X68114-SER
5	Box A.-Control	X68087
6	Control-Speed-Motor	056530
7	Screw-10-32X1-1/4 Truss	032936
8	Trans.-CONT.-80VA 230/24V	059993
9	Screw-8X1/4 SL Hex HD B	009894
10	Relay-DPDT-24VAC-30A	054703-03
11	Overload-Thermal REMOT	068109
12	Nut-Overload Reset	054431
13	Relay-SPST-30 A-240 V	032607-27
14	Relay-MTR Start TI#4CR-2-645	042007-34
15	Screw-10-32X3/8 Taptite	039381
16	Capacitor-Start 47-56UF/220T	037251-34
17	Strap-Capacitor 2-5/8"	056527

Item	Description	Part No.
18	Capacitor-Run 10UF/370V	033047
19	Capacitor-Run .8UF/400V	039482
20	Starter-3 Phase- 2.5 - 4A	066794-33H
21	Relay-3 Pole-20A-208/240	066795-33
22	Lug-Grounding 4-14 GA Wire	017667
23	Nut-10-32 MF Lock	020983
24	Screw-6-32 X 3/8	002201
25	Screw-8X1-1/4 RD HD TYP B	039420
26	Block-Terminal 3P-L1,L2,L3	039423
27	Block-Terminal 3P .25 SP	057201
28	Starter-3 Phase- 4 - 6.5A	066794-33J
29	Relay-MTR Start TI#4CR-1-625	039725-27
30	Grommet-Ribbon Cable	044999
31	Block-Terminal 7P Green	024156
32	Screw-8X1/2 SLTD Hex Washer	075763
33	Bracket-Ground Mount	056801
34	Trans.-CONT.-32VA 120/200/	054834
35	Overload-Thermal REMOT	067965
36	Shield-Noise Electric	062088
37	Filter-Corcom 6EH1	040140-001
38	Harness-Wire Control BX	059477

4

DEC Plate Assembly

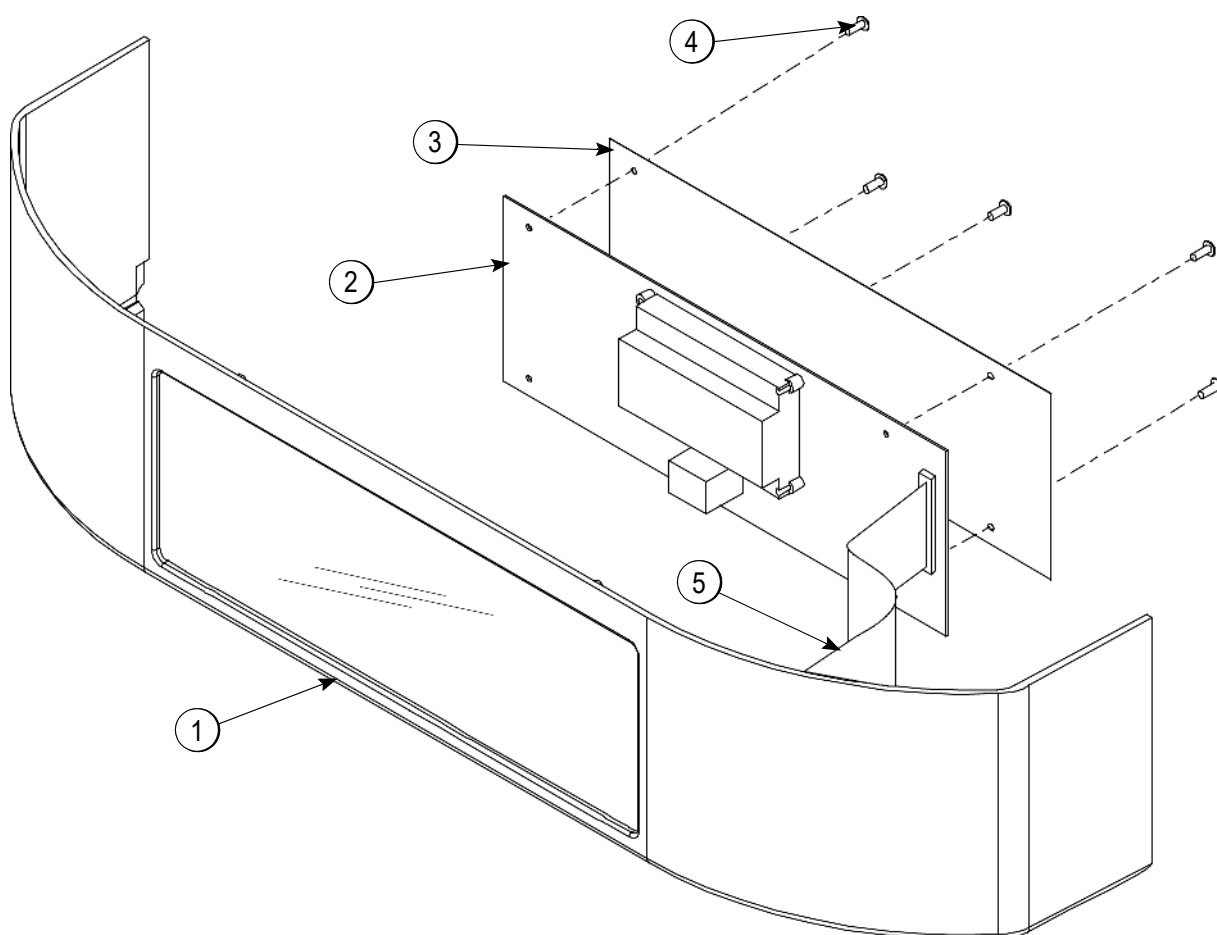

Figure 4-16

Item	Description	Part No.
1	Plate-DEC	056131
2	PCB A.-Interface C602 ROHS	X63921-SER
3	Insulator-PCB-Interface	057168

Item	Description	Part No.
4	Screw-6-32 X 3/8 Bin. HD	002201
5	Cable-Ribbon-14C-3"L	056864

Torque Coupling Assembly—X54722

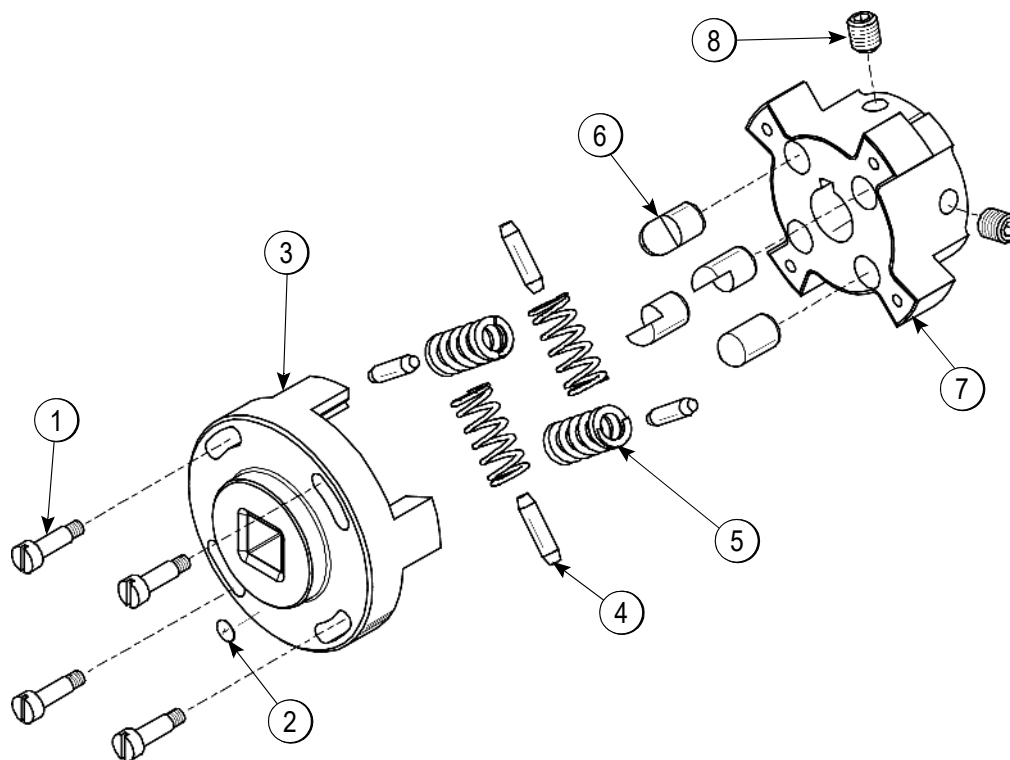

Figure 4-17

Item	Description	Part No.
1	Screw-Shoulder 3/16DX1/2L	039455
2	Label-Identification-GRN	049285-GRN
3	Coupling-Torque-Load	054724
4	Pin-Stop-Torque CPLG	054725

Item	Description	Part No.
5	Spring-3/8 OD X 3/16 Green	039454
6	Pin-Coupling-Torque	039453
7	Coupling-Torque-Drive	054723
8	Screw-5/16-18 X 3/8 Allen	025376

Blower A. X53725-

Figure 4-18

Item	Description	Part No.
1	Motor-Blower-Fan	053481

Glycol Heater Assembly—X55965-27

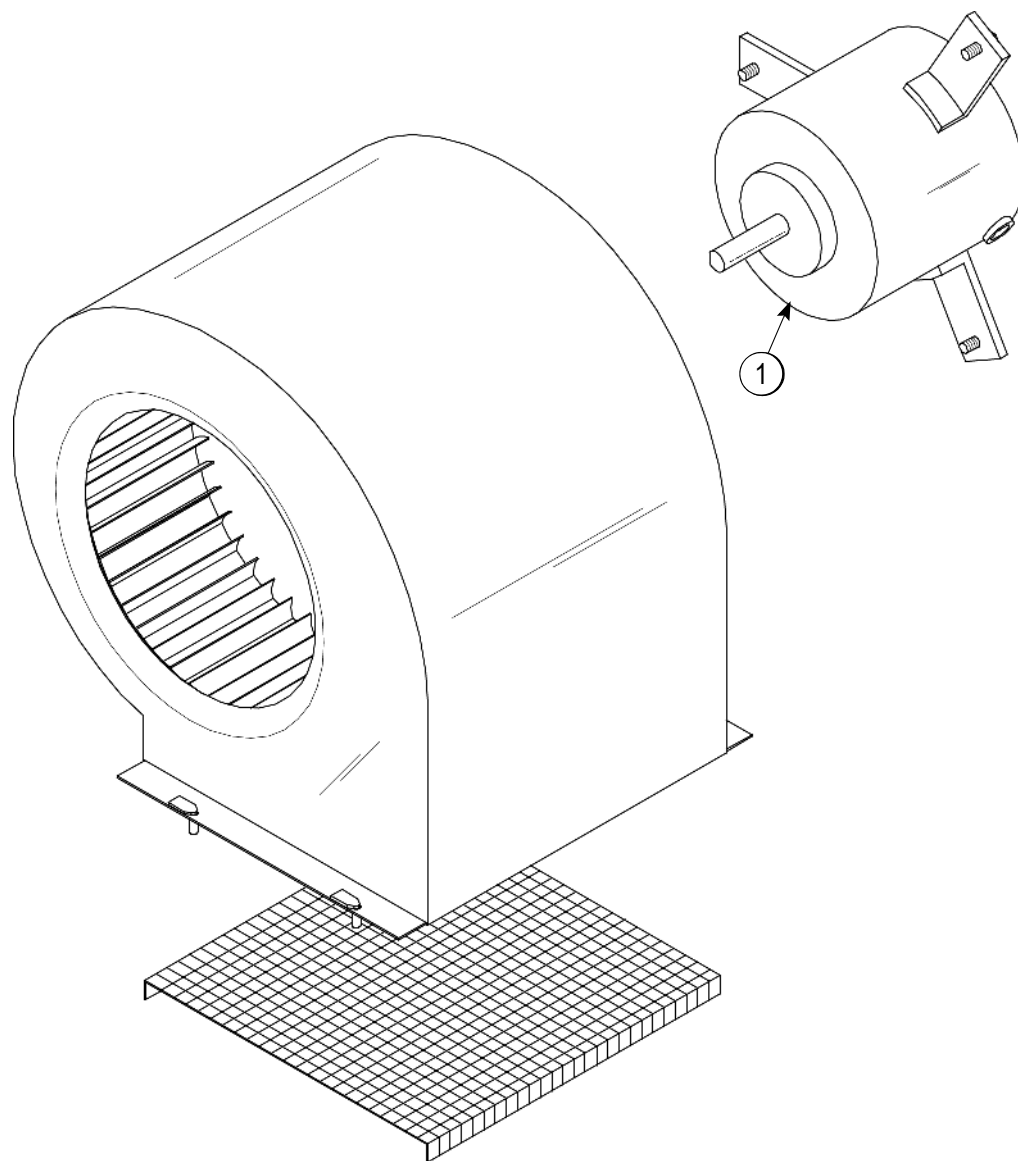
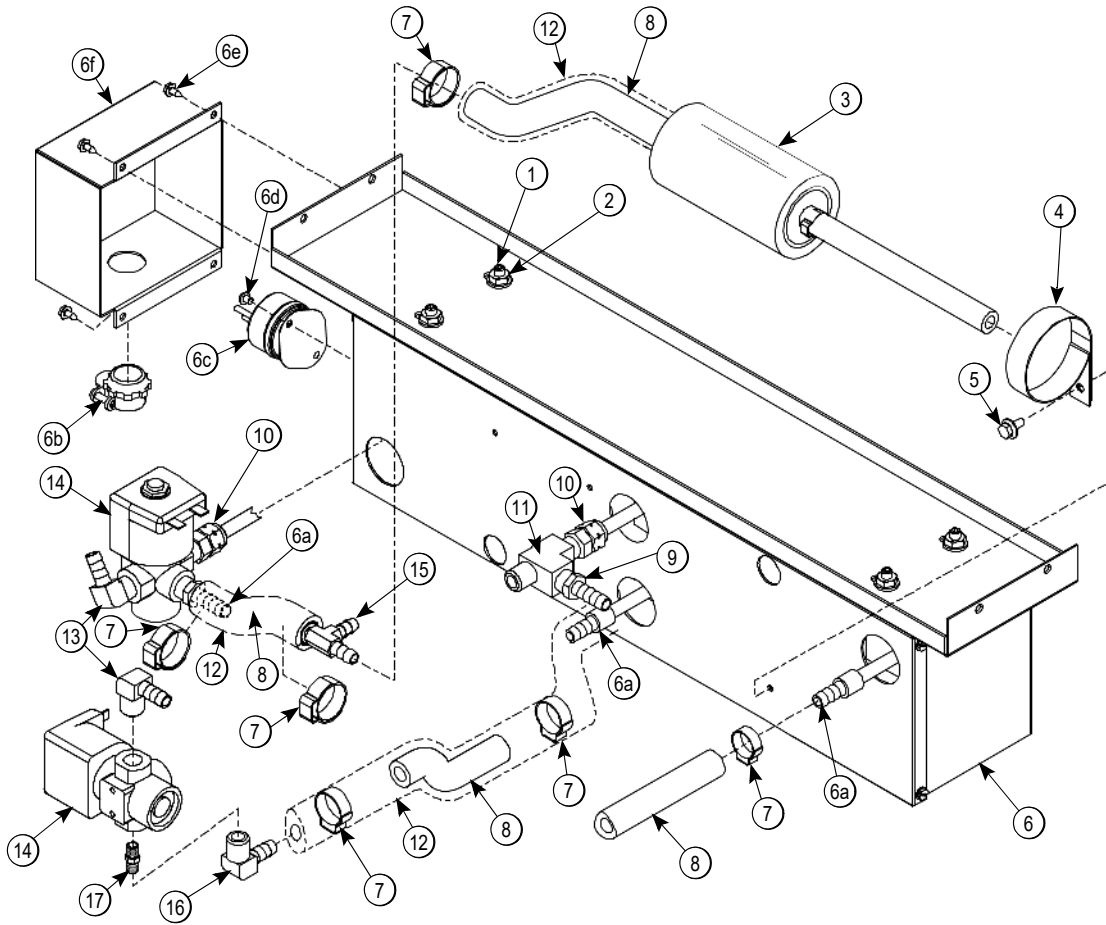

Figure 4-19

Item	Description	Part No.
1	Screw-1/4-20X1-1/4 Socket	068735
2	Nut-1/4-20 Whiz Flange LK	017523
3	Filter A.-Glycol	X47323
4	Clamp-Dryer 9.5" Long	002911
5	Screw-10-32X3/8 UNSL SER	039381
6	Heater A.-Glycol-4500	X47395-27
6a	Adaptor-5/16 Barb-5/16FS	047958
6b	Connector-BX 3/8 STR	014569
6c	Thermostat-Hi Limit	035786
6d	Screw-8-32X3/16 SLTD Pan	017551
6e	Screw-6X3/8 SLTD Hex	001825
6f	Cover-Terminal Heater	032864

Item	Description	Part No.
7	Clamp-Hose 35/64-Steples	047344
8	Hose-Rubber 5/16"ID X 9/16"	R502011
9	Adaptor-1/4MP X 5/16 Barb	047326
10	Adaptor-1/4MPT X 5/16	047333
11	Tee-1/4FPT X 1/4MPT X 1/4	021277
12	Armaflex 1/2 ID X 3/8wall	R50325
13	Elbow-1/4MP X 5/16 Barb	047327
14	Valve-Solenoid 3-W 1/4FPT	037954-27
15	Tee-5/16 Barb-Brass	047324
16	Elbow-1/4FP X 5/16 Barb	066767
17	Nipple-1/4PT X 1-3/8 LG	029937

Sensor Holder Assembly (X69102)

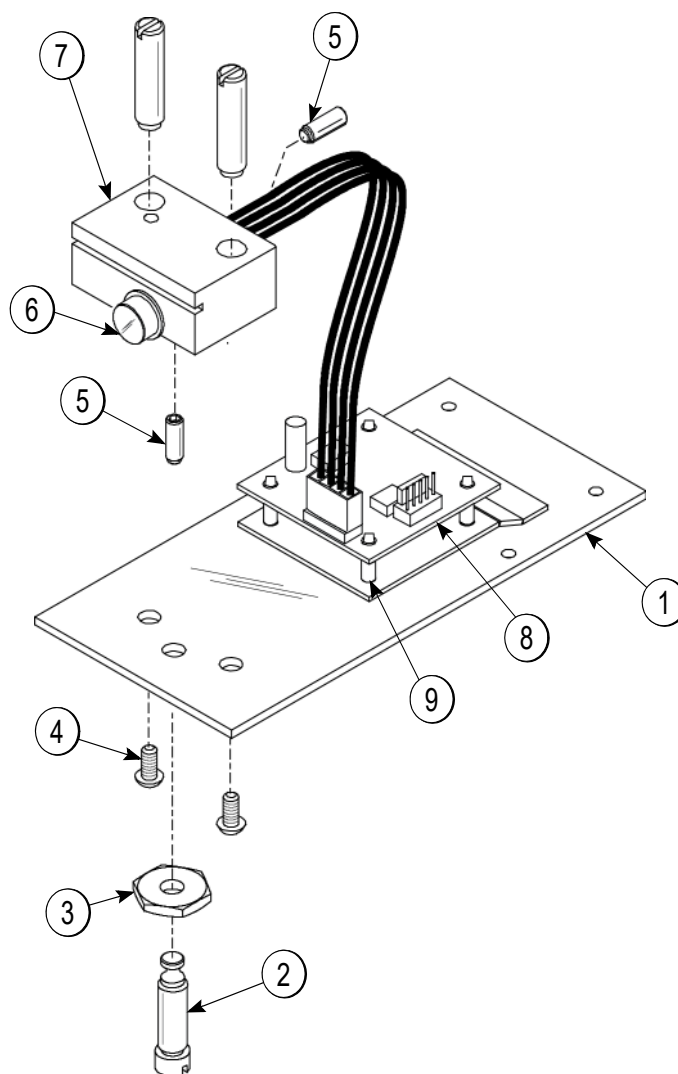

Figure 4-20

Item	Description	Part No.
1	Bracket A.-25 DCC Sensor	X69100
2	Screw-Adjustment 5/16-18	051574
3	Nut-5/16-18 Lock SS	043072
4	Screw 8-3/8 Slotted Pan	035647
5	Screw-10-32 X 9/16 Dog	038981

Item	Description	Part No.
6	Sensor A.-Pyroelectric	X59268-SER
7	Holder-25 DCC Sensor	069092
*8	PCB A.-PYRO	X69110-02S
*9	Standoff-Nylon 1/4"	059441

*Not Included In X69102 Sensor Holder Assy.

Heater A.—Syrup

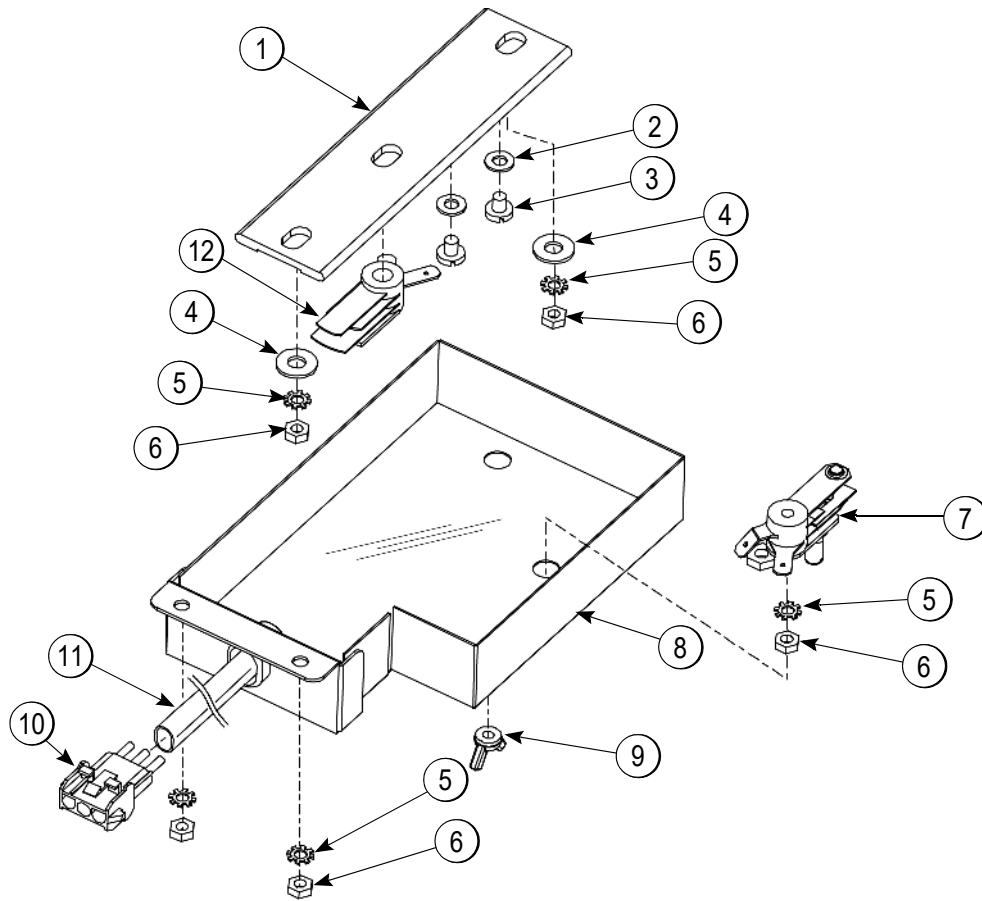

Figure 4-21

Item	Description	Part No.
1	Heater-Strip 175W / 240V	042782
2	Washer #10 Shakeproof	002681
3	Screw-10-32 X 3/8 Slotted	022263
4	Washer-3/16 Flat	005194
5	Washer-3 EXT. Tooth Lock	000964
6	Nut-8-32 Hex	000969

Item	Description	Part No.
7	Thermostat ADJ-Snap	049993
8	Box-Heater	043954
9	Nut-Wing 10-32 Nylon	034534
10	Connector-Mate Lock 3	022523
11	Sleeve-Wire .294 ID	020917-42
12	Thermostat-Hi Limit Snap	049992

Accessories

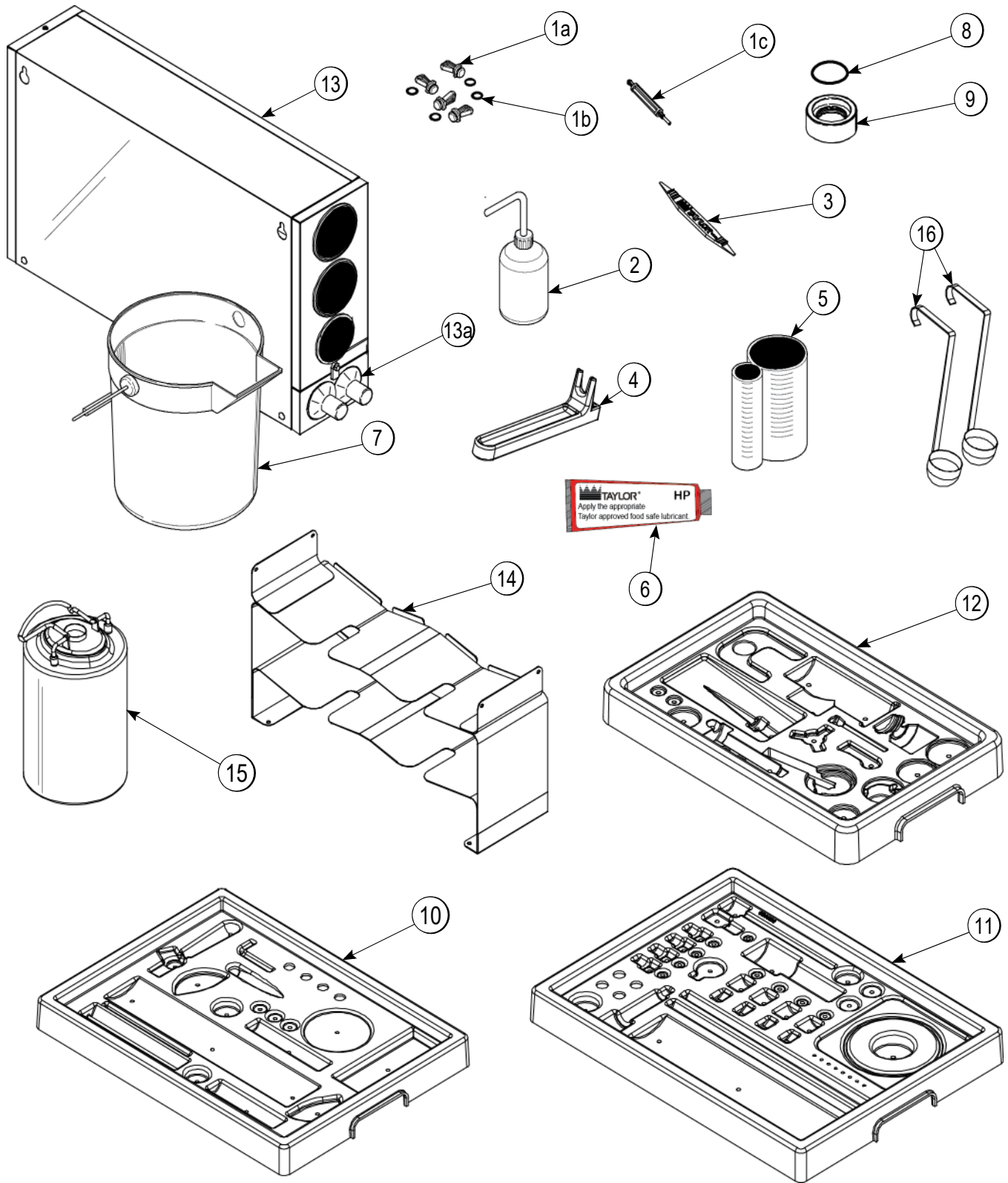

Figure 4-22

PARTS

Accessories

Item	Description	Part No.
1	Kit A.-Syrup Plug Kit (Includes items 1a-1c)	X58474
1a	Plug-Syrup Port TTS	053867
1b	O-ring-11mm ID x 2mm w/gr	053890
1c	Tool-Seal Install/Remove	035460
2	Bottle-Plastic Wash	044818
3	Tool-O-ring Removal	048260-WHT
4	Tool-Shaft-Drive-Pump-Hopper	057167
5	Cup-Divided Syrup	017203
6	Lubricant-Taylor Hi-Performance	048232
7	Pail-Mix 10 Qt.	013163
8	O-ring - 1-11/16 OD (Draw Valve Cap)	041923
9	Cap A.-Valve-Draw	X54704

Item	Description	Part No.
10	Tray-Parts Soft Serve Side	059087
11	Tray-Parts Shake Side	059088
12	Tray-Parts Pump Soft Serve	056525
*13	Dispenser A.-Cone	X59489
*13a	Baffle-Rubber Cone	052193
*14	Tray A.-Syrup (Syrup in Bag)	X59143
*15	Tank-Syrup 4 qt.	056673
*16	Ladle-1 Ounce	033637-1
**	Kit A.-Peristaltic Pump Tube	X54978
**	Kit A.-Topping Pump Spares	X53795
**	Kit A.-Tune Up C602/C606	X49463-59
**	Deflector-Blower Exhaust	047912
**	Box-Tool 15" Plastic	058669

*For machines manufactured prior to serial number M1080000.

**Not Shown

Syrup Pump X53800—BRN/TAN

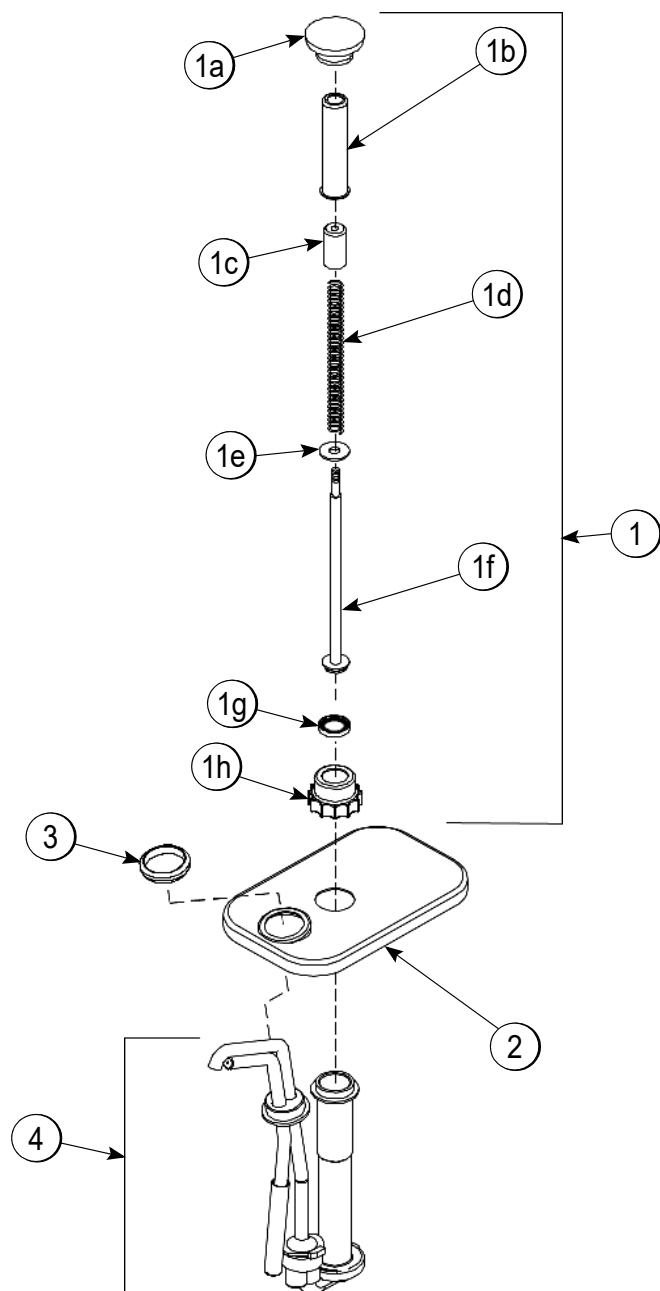
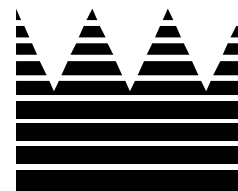

Figure 4-23

Item	Description	Part No.
1	Plunger A.	X36576-TAN X36576-BRN
1a	Knob-Plunger	032762-TAN 032762-BRN
1b	Tube-Plunger	032757
1c	Insert-Plunger	032758
1d	Spring-Plunger-Syrup Pump	032761
1e	Washer-Nylon	032760
1f	Plunger	036578
1g	Seal A.	X33057
1h	Nut-Plunger	036577
2	Lid-Pump	036579
3	Nut-Spout	039680
4	Pump A.-Syrup Heated	X53798-SER

Note: Shown for reference only. Not supplied with new machines.



Section 5: Parts List

- **4 Tank System**
- **4 Bag System**
- **Water-Cooled**
- **200V 60Hz 3PH**
- **220V-240V 50Hz 3PH**
- **200V 50Hz 3PH**
- **380V-415V 50HZ 3N~ (4-Wire)**

+ See data label for model specifications.

For recycling instructions please see our website: www.taylor-company.com

Description	Part Number	Qty.	Warranty Class	Remarks
C60233FANU - 208-230V 60Hz 3PH - 3 Wire - A/C-Bristol-(R449A) with Cup/Cone Dispenser				
Accumulator-Copper 2"DIA 10"LG	047062	2	103	
Agitator A.-Mix Hopper-20QT-HT	X44797	2	103	
+Cap-Magnet *HT*	080826	2	103	S/N M2042826 and Up - Replaces 044796
Bearing-Door-Front 1.390 OD	055605	1	000	Shake
Bearing-Front-Shoe	N/A	1	000	Use X50350 Kit A.-Beater-Front Shoes
+Shoe-Front Helix *Rear*		1	000	
+Shoe-Front Helix *Front*		1	000	
Bearing-Rear Shell-Nickel	031324	2	000	
+Guide-Drip Seal	028992	2	000	
+Nut-Brass Bearing	028991	2	000	
+O-ring-1/2OD X .070W	024278	4	000	
+Washer-Bearing Lock	012864	2	000	
Beater A.-3.4QT-1 Pin-Support	X46231	1	103	Soft Serve
+Blade-Scraper-Plastic 8-1/8L	084350	2	000	7/1/16: Replaces 046235 Blade and 046236 Clip
+Shaft-Beater	032564	1	103	
Beater A.-7QT-Fluted Blade	X50958	1	103	Shake
+Blade-Scraper-FCB 16L	041103	2	000	
+Shaft-Beater*7QT Fluted Blade	050985	1	103	
Belt-RD 3/16 Green	062191-6	1	000	K4090000 and Up - Agitator
Belt-RD 3/16 Green	062191-7	1	000	K4090000 and Up - Agitator
Belt-AX31	041575	1	000	Shake Side
Belt-AX33	024396	2	000	
Blade A.-Spinner-Aluminum-HT	X59331	1	103	

+ Available Separately

Model C602

Parts List

Description	Part Number	Qty.	Warranty Class	Remarks
Blade-Scraper-FCB 16L	041103	2	000	
Blade-Scraper-Plastic 8-1/8L	084350	2	000	7/1/16: Replaces 046235 Blade and 046236 Clip
Block-Hinge	058614	4	103	
+Pin-Hinge	058615	4	103	
Block-Terminal 3P L1,L2,L3	039423	2	103	One Block Was Used For LON S/N M5055866 and Prior
Block-Terminal 3P .25 Spade	057201	2	103	
Block-Terminal 4 Pole Green	080967	3	103	6/13/2012
Block-Terminal 3 Pole Green	080968	1	103	6/13/2012
Plate-End Terminal Block	080969	1	103	6/13/2013
Blower A.	X53725-27	1	103	STD All machines K6126088 and Up - Replaces X64529
Motor-Fan 208-230V 50/60 Hz	053481-27	1	103	
Capacitor-Run 7.5UF/370V	034749	1	103	
Boot-Capacitor-Insulating	031314	1	000	
Bottle-Wash-Plastic	044818	1	000	
Brush A.-Package-HT	X44127	1	000	
Brush-Rear BRG 1"D X 2"LG X 14	013071	1	000	
Brush-DBL End-Pump & Feed Tube	013072	1	000	
Brush-Draw Valve 1"OD X 2"X17"	013073	1	000	
Brush-Draw Valve 1-1/2"OD X 3"	014753	1	000	
Brush-Mix Pump Body-3" X 7" WH	023316	1	000	
Brush-1/2" DIA	033059	1	000	
Brush-End-Door-Spout-SS-HT	039719	1	000	
Brush1-7S0E21T5LVB	050103	1	000	
Brush-Pump Spout *mc13*	054068	1	000	
Bumper-Recessed	057910	1	103	Used With Draw Valve Solenoid

Description	Part Number	Qty.	Warranty Class	Remarks
Cabinet A.-ULT Syrup *C602*	X55984	1	103	
Cable A.-Low Voltage *C602*	080885	1	103	S/N M2071851 And Up
Cable A.-4 Cond 4 Pin	X62616	1	103	
Cable-Ribbon-10C-34"L-DIL/DIL	040040-023	1	103	J3 If Ss To Speed Control
Cable-Ribbon-14C-3"L-SIL/SIL	056864	1	103	DEC Plate Interface
Cable-Ribbon-20C-16"L-DIL/DIL	040040-049	1	103	J9 If Shake To To J7 Uvc
Cable-Ribbon-20C-17"L-DIL/DIir	040040-013	2	103	J12 If Ss To J11 If Shake, J12 If Shake To J2 Uvc
Cable-Ribbon-50C-20"L-DIL/DIL	040040-011	1	103	J2 If Ss To J11 Uvc
Cable-Ribbon-50C-25"L.DIL/DIL	040040-025	1	103	J2 lfshake To J10 Uvc
Cable-Control/interface *	069023	1	103	S/N M1037066 and Up - Uvc4
Cable-Control/Ion Gateway	069025	*	103	Used S/N M5055866 and Prior With Lon
Cap A.-Valve-Draw-Insulated	X54704	1	103	Shake Door
Cap-Magnet *HT*	080826	2	103	
Cap-Restrictor	033107	1	000	
Cap-Rubber	011844	4	103	
Cap-Valve Body Shake	056873-10	1	103	
Cap-Valve Body SS	056874-12	1	103	
Caster-4" SWV 3/4-10 STM	044106	2	103	S/N K9046770 and Up
Caster-4" SWV 3/4-10 STM W/BRK	046437	2	103	
Clip-Thermistor Probe	080767	2	000	M2105367 and Up With Chip Style Thermistor Probe
Compressor L63a113dbla-40w CCH	048259-33H	1	512	Soft Serve
Compressor M63b203dbdb-40w CCH	062274-33H	1	512	Shake
+Grommet-Compressor Mounting	037428	8	000	
+Sleeve-Mounting-Comp.	039924	8	000	
Condenser-AC 12LX18HX3.12T-5RW	055813-1	1	103	Left-Shake Side

Description	Part Number	Qty.	Warranty Class	Remarks
Condenser-AC 12LX18HX3.12T-5RW	055813-2	1	103	Right-Soft Serv
Control-Gateway-LON *602*	X72848SER2	*	212	Used S/N M5055866 and Prior With Lon
Control-Interfce-HT-SS-UK ROHS	063964-SER	1	212	S/N M2125873 and Up - ROHS Compatible Version Direct Sub X53453-Ser
Pcb A.-ROHS-Person-HT-SS	063922-SER	1	212	
Control-ROHS-HT INTF Base-UK	063920-SER	1	212	
Control-Interf-HT-SH-C602 ROHS	063965-SER	1	212	Replaces X59076-Ser and X63965-Ser
Control-ROHS-Person*C602*sh	063923-SER	1	212	
Control-ROHS-HT Intf Base-UK	063920-SER	1	212	
Control-ROHS-Interface *C602*	063921-SER	1	212	DEC Plate-Standard and ROHS machine Replaces X55960-Ser and X63921-Ser
Control-Speed-Motor	056530	1	103	
Core-Schrader Valve-Teflon	037047	4	103	
Cover A.-25dcc Pyr Sns*C602	X69097	1	103	S/N M1094977 and Up - Clear Cup Shake Holder
Cover-Hopper *black*	053809SER1	*	103	N/A Use X65178 Kit A.-Cover-Hopper*dual*blk
+Pin-Retaining-Hopper Cover	043934	2	103	
Coupling A.-Drive-Spinner	X20329	1	103	
Coupling A.-Torque-Shake*4spr*	X54722	1	103	
Coupling-Torque-Drive Tts	054723	1	103	
Coupling-Torque-Load-Sq *tts*	054724	1	103	
Label-Identification-Green	049285-GRN	1	000	
Pin-Coupling-Torque	039453	4	103	
Pin-Stop-Torque Coupling .792	054725	4	103	
Screw-5/16-18x3/8 Allen Set	025376	2	000	
Screw-Shoulder 3/16DX1/2L-SS	039455	4	000	
Spring-3/8 ODx3/16 IDX1L-Green	039454	4	103	

Description	Part Number	Qty.	Warranty Class	Remarks
Coupling-Drive 3/4 Hex X 1-7/8	012721	1	103	
Coupling-Flexible W/screws	020108	1	103	
Cup-Divided Syrup	017203	1	000	
Decal-Inst-CIn-Day-HT-C602	057064	1	000	
Decal-Inst-CIn-Man-HT-C602	057065	1	000	
Decal-Mag-Closing Check	044309	1	000	
Decal-Mag-Symbol-ENG/F/G-C602	058287	1	000	
Decal-Set Of 4 Colored Flavors	022105	1	000	
Decal-Set Of 4 Syrup Flavors	021523	1	000	
Decal-Syr Compartment-Romance Comb	021571	1	000	
Decal-Troubleshoot	038374	1	000	
Deflector-Blower Exhaust	047912	1	103	
Deflector -Torque Coupling	054698	1	000	
Diagram-Wiring *C602*C606	059480-33	1	000	
Door A.-Cabinet *C602*	X58607-SER	2	103	S/N K7013072 and Up Replaces X58607-L and X580607-R
Basket-Door-Wire	059144	2	103	
Block-Hinge	058613	4	103	
Handle-Door Short	065933	2	103	
Rivet-3/16 X.062-.270 Grip	046052	12	000	
Screw-10-32x3/8 SITD Round	006749	8	000	
Screw-8-32x1/2 Socket Head	058322	8	000	
Washer-#8 External Tooth Loc	000964	8	000	
Door-Machined-Tts Shake*black*	X55825SER2	1	103	Shake
+Cap A.-Valve-Draw-Insulated	X54704	1	103	
+O-ring-1-11/16 OD X.139w	041923	1	000	

Description	Part Number	Qty.	Warranty Class	Remarks
+O-ring-6 In ODx5 3/4 IDx 1/8	033493	1	000	
+Retainer-Syrup Valve *tts*	054554	4	000	
+Valve A.-Draw *C602*	059000	1	103	
+O-ring-Draw Valve-Shake	020571	2	000	
+Spinner	034054	1	103	
+Seal-Spinner Shaft	084696	1	000	Replaced 036053
+Grommet-Valve-Spinner *C602*	062240	1	000	
Door A.	X87683-SER1	1	103	Soft Serve
Baffle A.-Threadless	087708	1	103	
+Gasket-Door HT 4"-Double	048926	1	000	
+Handle A.-Draw *C602*	X56421-1	1	103	
+O-ring-1/4 OD X .070w 50 Duro	015872	1	000	
+Screw-Adjustment-5/16-24 *602*	056332	1	103	
+Kit A.-Beater-Front Shoes	X50350	1	000	Bearing-Front Shoes
+Pin-Handle-SS *C602*	055819	1	103	
+Valve A.-Draw *C602*	X55820	1	103	
+O-ring-7/8 OD X .103w	014402	3	000	
Dryer-Filter-Hp62-3/8 X 1/4s	048901	2	000	
Fastener-Clip 1/4-20 U-Type	045865	19	000	Panels
Filter-Air-18.00lx13.50hx.70w	052779-3	2	000	
Filter-Corcom 2vr1	032567	*	103	Used S/N M5055866 and Prior With Lon
Filter-Corcom 6eh1	040140-001	1	103	
Filter-Inline-Glycol-40 Micron	041670	1	000	
Fitting A.-Syrup Jug TTS 36"	X53353-BLU	1	103	
Cap-Ultimate Syrup	053040-BLU	1	000	

Description	Part Number	Qty.	Warranty Class	Remarks
Ferrule-.625 ID NP Brass	053036	2	000	
Fitting-Peristaltic Pump	054526	1	103	
Hose-Beverage 3/8"ID X 5/8"OD	053052-36	1	000	
O-ring-1/2OD X .070w	024278	1	000	
Tube A.-Syrup Pick Up	X53175	1	103	
Fitting A.-Syrup Jug Tts 36"	X53353-BRN	1	103	
Cap-Ultimate Syrup	053040-BRN	1	000	
Ferrule-.625 ID NP Brass	053036	2	000	
Fitting-Peristaltic Pump	054526	1	103	
Hose-Beverage 3/8"ID X 5/8"OD	053052-36	1	000	
O-ring-1/2OD X .070w	024278	1	000	
Tube A.-Syrup Pick Up	X53175	1	103	
Fitting A.-Syrup Jug Tts 36"	X53353-RED	1	103	
Cap-Ultimate Syrup	053040-RED	1	000	
Ferrule-.625 ID NP Brass	053036	2	000	
Fitting-Peristaltic Pump	054526	1	103	
Hose-Beverage 3/8"ID X 5/8"OD	053052-36	1	000	
O-ring-1/2OD X .070w	024278	1	000	
Tube A.-Syrup Pick Up	X53175	1	103	
Fitting A.-Syrup Jug Tts 36"	X53353-WHT	1	103	
Cap-Ultimate Syrup	053040-WHT	1	000	
Ferrule-.625 ID NP Brass	053036	2	000	
Fitting-Peristaltic Pump	054526	1	103	
Hose-Beverage 3/8"ID X 5/8"OD	053052-36	1	000	
O-ring-1/2OD X .070w	024278	1	000	

Description	Part Number	Qty.	Warranty Class	Remarks
Tube A.-Syrup Pick Up	X53175	1	103	
Fitting-Panel Mount Qd .250id	056674	4	103	
Form-Quality Report By Fax	065712	1	000	
Fuse-4am1p70-l2n15line-Non Delay	064535	1	103	S/N K6064458 and Up Replaces 062224
Fuse-6 Amp.	076301	1	000	
Fuse-12 Amp-Buss Bk/abc-12-R	064536	1	000	S/N K6065606 and Up Replaces 062431
Holder-Fuse-Inline-Type Hfa-	064538	2	103	
Gear A.*reducer 4.21:1 Service	021286-SER1	2	212	
Grommet-7/16 X 5/16 Shock Absb	016212	4	000	
Grommet-Compressor Mount	037428	8	000	
Grommet-Valve-Spinner *C602*	062240	1	000	
Guide A.-Drip Pan Center*C602*	X55972	1	103	Front Panel
Guide A.-Drip Pan-Mix Pump	X48228	2	103	Mix Pumps
Guide A.-Drip Pan-Right *C602*	X55982	1	103	Soft Serve
Guide A.-Drip Pan-Left *C602*	X55983	1	103	Shake
Guide-Actuator	062199	1	103	
Guide-Drip Pan Center	056173	1	000	
Guide-Drip Seal	028992	2	000	
Guide-Filter*444*632s*(8)754ac	053784	2	103	
Guide-Troubleshooting-HT	046735	1	000	
Harness-C602 Pyro To SHK Pers.	059135	1	103	
Harness-Rectifier/relay/solen.	059478	1	103	
Harness-Wire-Blower A/c HT	056098	1	103	
Harness-Wire-Compressor*C602*I	056428-H1	1	103	Replaces 056428-H 8/26/14
Harness-Wire-Compressor*C602*r	056429-H1	1	103	Replaces 056429-H

Description	Part Number	Qty.	Warranty Class	Remarks
Harness-Wire-Beater Mtr*C602*	056428-H2	1	103	Use With 056428-H1 and H2
Harness-Wire-Btr/comp *C602*I*	056428-H	*	103	S/N K9046770 and Up - Comp Sump Heaters
Harness-Wire-Btr/comp *C602*r	056429-H	*	103	S/N K9046770 and Up - Comp Sump Heaters
Harness-Wire-Control Box	080886	1	103	
Harness-Wire-Control-High	059476	1	103	
Harness-Wire-Control-Low	080774	1	103	M2105367 and Up - With Chip Style Thermistor Probe
Probe-Thermistor, Ip68 Rigid	082397	*	103	Replaces 038061-Blk/039470-Blk/080503, M4026480 and Up
Kit A.-Probe-Thermistor Ip68	X82397-SER	5	103	
Harness-Wire-Low Volt-Syrup	066346	1	103	S/N K8104741 Pump Ultimate Syrup Peristaltic - Re- Placed 056432
Harness-Wire-Syrup Heaters	056431	1	103	
Heater A.-Glycol-4500 W-Prtl	X47395-SER	1	103	
+Thermostat-HI Limit Man Reset	068953-SP	1	103	M5064707 and Up Replaced 035786 Thermostat
+Filter-Inline-Glycol-40 Micr	041670	1	000	Glycol Heater
+Adaptor-1/4mp X 5/16 Barb-Br	047326	2	103	
+Clamp-Hose 35/64-Stepless Ea	047344	5	000	
+Hose-Rubber 5/16"ID X 9/16"OD	R502011	5'	000	
+Pump-Glycol-1/8npt-1650 Rpm	041785	1	212	
+Valve-Solenoid 3-W 1/4fpt 24	037954-27	2	103	
Heater-Strip-175w-240v	042782	2	103	Syrup Rail - Part Of Front Panel X55981
Holder A.-25dcc Pyr Sns *C602	X69102	1	103	M1094977 and Up - Clear Cup Shake Holder Update 223
Bracket A.-25dcc Pyr Sns*C602	X69100	1	000	
Holder-25dcc Pyr Sns	069092	1	103	
Nut-5/16-18 Special Hex Nut	043072	1	000	
Kit A.-Guide Pin	X38980-SER	2	103	
Screw-10-32x9/16 Socket Set	038981	2	000	

Description	Part Number	Qty.	Warranty Class	Remarks
Screw-Adjustment-5/16-18	051574	1	103	
Holder-Cup-Shake-4.313 DIA	056008	1	103	S/N M1094977 and Up - Clear Cup Shake Holder Update
+Clip-Spring-Cup Holder	068394	2	103	M1094977 and Up - Clear Cup Shake Holder Update
Holder-Fuse-Inline-Type Hrk-	064538	2	103	Use W/064535 4a, 064536 12a, 064537 15a Fuses
Housing A.-Agitator *long*	X51661	1	103	
Magnet A.-Agitator-Inner	066937	1	103	Replaces X41733 and 006812 Set Screw
Housing A.-Agitator *short*	X51664	1	103	
Magnet A.-Agitator-Inner	066937	1	103	Replaces X41733 and 006812 Set Screw
Ic-15a-Bridge-1000v Fastons	040172-102	1	212	Replaces X59290-Ser Pcb A.-Dual Bridge K6081879/up
Jack A.-Flavorburst	X56353	1	103	
Jar-Syrup*plastic*shallow	036573	*	103	Shipped With machines Prior To S/N M107 U/d 221
Jar-Syrup*stainless*shallow	036574	*	103	Shipped With machines Prior To S/N M107
Kit A.-Beater-Front Shoes	X50350	1	000	Bearing and Shoes Ss
Kit A.-Cover-Hopper*dual*blk	X65178	1	103	X65368 Kit A.-Cover-Hopper*single
Label-Caution-Agitator	045191	2	000	
+Pin-Retaining-Hopper Cover	043934	2	103	
Kit A.-Cover-Hopper*single*blk	X65368-SP	2	103	
Kit A.-Peristaltic Pump One-Tube	X54978	1	000	One Tube
Kit A.-Per1i7s0t21a5ltic Pump Four-Tubes	X54979	1	000	Four Tubes
Kit A.-Solenoid Draw Valve	X81034-SER	1	103	
Kit A.-Topping Pump Spares	X53795		000	Shipped With machines Prior To S/N M107 U/d 221
Seal A.	X33057		000	Shipped With machines Prior To S/N M107
O-ring-9/16 OD X .103w	016369		000	Shipped With machines Prior To S/N M107
Washer-Nylon	032760		000	Shipped With machines Prior To S/N M107
Brush-1/2" DIA	033059		000	Shipped With machines Prior To S/N M107

Description	Part Number	Qty.	Warranty Class	Remarks
O-ring-1 OD X .103w	048148		000	Shipped With machines Prior To S/N M107
O-ring-1-5/16 OD X.103w	048149		000	Shipped With machines Prior To S/N M107
Brush-Pump Spout *mc13*	054068		000	Shipped With machines Prior To S/N M107
Kit A.-Tool Solenoid Adjust	X59702	1	103	
Kit A.-Trans 120/208/240v 24v	X81783-27S	1	000	Replaces 030132-27
Kit A.-Tune Up-C602	X49463-94	1	000	7/1/16: Replaces X49463-59
Kit A.-Pump-Simplified SS/shk	X56200-10	2	000	
O-ring-1-3/4 OD X .139w	008904	2	000	
O-ring-11/16ODX.103W-Red	016132	4	000	
O-ring-2-1/8 OD X .139w-#225	020051	4	000	
O-ring 1/2 ID X .139w	048632	4	000	
Gasket-Simplified Pump Valve	086097	2	000	
Ring-Check-Feed-Tube	056524	2	000	
Kit A.-Draw Valve *shake C602*	X56200-12	2	000	
O-ring-1-1/16 OD X.139w	020571	4	000	
Cap-Restrictor	033107	2	000	
Seal-Spinner Shaft	036053	2	000	
Kit A.-Door/BARREL*SHAKE C602	X56200-13	1	000	
Seal-Drive Shaft	032560	1	000	
O-ring-6 In ODx5 3/4 IDx 1/8	033493	1	000	
O-ring-1-11/16 OD X.139w	041923	1	000	
O-ring-11mm ID X 2mm W Green	053890	4	000	
Bearing-Door-Front 1.390 OD	055605	1	000	
Kit A.-Door/barrel SS C602	X56200-14	1	000	
O-ring-7/8 OD X .103w	014402	3	000	

Description	Part Number	Qty.	Warranty Class	Remarks
O-ring-3/8 OD X .070w	016137	2	000	
Seal-Drive Shaft	032560	1	000	
Gasket-Door HT 4"-Double	048926	1	000	
Kit A.-Beater-Front Shoes	X50350	1	000	
Shoe-Front Helix *rear*		1	000	
Shoe-Front Helix *front*		1	000	
Bearing-Front-Shoe		1	000	
Kit A.-Syrup Valve Tts	X56200-15	1	000	
O-ring-11mm ID X 2mm W Green	053890	4	000	
O-ring-.441 OD X .070w	500205	4	000	
Valve-Check-Duckbill	500598	4	000	
Blade-Scraper-Plastic 8-1/8l	084350	2	000	
Shield-Pyroelectric Sensor	064942	1	000	Added To Tuk's 10/1/15
Tool-O-ring Removal-Freezer	048260VWHT	1	000	
Kit-Mcd Dispenser-Syrup Rail	069619		NNN	Contact Franke 800-423-5247 Ref P/n270071
Kit A.-Probe-Thermistor Ip68	X82397-SER	5	103	Replaces 038061-Blk/039470-Blk/080503, M4026480 and Up
Label-1/4 X 1-1/2 Long-Red	022707	4	000	
Label-1/4 X 1-1/2 Long-Dk Blue	022708	4	000	
Label-1/4 X 1-1/2 Long-White	022709	4	000	
Label-1/4 X 1-1/2 Long-Brown	022710	4	000	
Label-3ph Mtr Prot/1ph C-	025949	1	000	
Label-Attn Svc Eng	015068	2	000	
Label-Caution-Agitator	045191	2	000	
Label-Caution-Btr Strt G3	039897	1	000	
Label-Caution-Grd-Perm-Eng/sp	032164	1	000	

Description	Part Number	Qty.	Warranty Class	Remarks
Label-Caution-Overheat-Romance	030995	1	000	
Label-Ck Mtr Rotate-Cw-Eng/spn	020090	1	000	
Label-Door-Move Part	032749	1	000	
Label-Overload Setting	045384	1	000	
Label-Reset-Mix Pmp	022723	2	000	
Label-Reset-Mix Pmp	044452	2	000	
Label-Sw-Power-Off/on-Symbols	052632	1	000	
Label-Warn-Condenser-Sharp	059287	2	000	
Label-Warn-Cover	051433	5	000	
Label-WA1R70N2-1E5LEC-TW-Small	032718	1	000	Available In Other Languages 032718-Ru Russian
Lid-Syrup Jar	042706	*	103	Shipped With machines Prior To S/N M107 U/d 221
Ladle-1 OZ-120D Bend In Hand	033637-1	*	103	Shipped With machines Prior To S/N M107
Line A.-Syrup	X62426-8	4	103	
Ferrule-.625 ID NP Brass	053036	4	000	
Fitting-Peristaltic Pump	054526	4	103	
Hose-Beverage 3/8"ID X 5/8"O	053052-8	4	000	
O-ring-1/2OD X .070w	024278	4	000	
Line A.-Syrup Door *C602*	X56652	4	103	
Ferrule-.625 ID NP Brass	053036	8	000	
Fitting-Syrup Elbow	056651	4	103	
Fitting-Syrup Nose .125 Slot	056650	4	103	
Hose-Beverage 3/8"ID X 5/8"O	053052-9	4	000	
Insert-Qd-Cpc-3/8 Barb-Plast	056675	4	103	
O-ring-11mm ID X 2mm W Green	053890	4	000	
Valve-Check-Duckbill	500598	4	000	

Description	Part Number	Qty.	Warranty Class	Remarks
Line A.-Syrup Blue *C602*	X56687	1	103	Stainless
Line A.-Syrup Brown *C602*	X56684	1	103	Stainless
Line A.-Syrup Red *C602*	X56685	1	103	Stainless
Line A.-Syrup White *C602*	X56686	1	103	Stainless
Lubricant-Taylor HI Perf-4 Oz	048232	1	000	
Man-Oper C602	057888-M	1	000	
Motor-1.0 HP	013102-33	1	212	
Motor-1.5 HP	021522-33	1	212	
Motor A.-Agitator *C602*	X55971-27	1	103	
Gear A.*reducer-Agitator	047988	1	103	
Motor-Agitator	047987-27	1	103	
+Capacitor-Run .8uf/400v	039482	1	103	
Pin-.084 OD/14-20 AWG-Strip	021624	3	103	
Pulley-AGT Mtr-1.910pdx3/8bo	042063	1	103	
Screw-8-32x3/16 Socket Set	006812	2	000	
Motor A.-Spinner W/plug	X35584SER2	1	103	
Capacitor-Run 10uf/370v For Spinnr	033047	1	103	7/12/4 and Up Use With 1/8 HP Motor
Capacitor-Run 3uf/550v	035342-27	*	103	7/11/4 and Prior Use With 1/15 HP Motor
Motor-Gear Ultimate Syrup	058725	4	103	S/N K8104741 - Pump Ultimate Syrup Peristaltic
Motor-Gear 161 Rpm/short Shaft	066520	*	103	K8104740 and Prior Use X58725-Ser Kit To Update
+Harness-Wire-Low Volt-Syrup Pm	056432	*	103	K8104740 and Prior Use X58725-Ser Kit To Update
Motor-Reducer-Service	044723-34S	1	212	Shake
Motor-Reducer 32 Rpm-Hpr Pumpm	036955-34S	1	212	Soft Serve
Nut-Stud-Black-1.00	055989	8	103	Short - 5/20/04 And Up
Nut-Stud-Black 2.563 Long	058764	*	103	Long - Used Prior To 5/19/04

Description	Part Number	Qty.	Warranty Class	Remarks
Pail-Mix 10 Qt.	013163	1	000	
Pan-Drip 19-1/2 Long	035034	1	103	Front Panel
Pan-Drip-Rear *C602*	X56003	2	103	Mix Pumps
Pan-Drip-Side *C602*	X56005	2	103	Side Panel
Panel A.-Front *C602*	X84478-27	1	103	Replaced X55981-27
Heater-Strip-175w-240v	042782	2	103	Front Panel Syrup Rail
Label-Adj Temp-Symbol	030994	2	000	Front Panel Syrup Rail
Label-Inst-Syrup Label Reset	055810	2	000	Front Panel Syrup Rail
Plug-Drain-Wyott	023953-5	3	103	Front Panel Syrup Rail
Thermostat-Adj-Snap Acting	049993	2	103	Front Panel Syrup Rail
Thermostat-HI Limit-Snap Act	049992	2	103	Front Panel Syrup Rail
Panel A.-Upper Front *C602*	X55977	1	103	
Panel-Rear-Lower *C602*	055959	1	103	
Panel-Rear-Upper *C602*	066724	1	103	S/N K9051303 and Up
Panel-Side Left *C602*	055957	1	103	
Panel-Side Right *C602*	055950	1	103	
Panel-Syrup Cabinet-Back*C602*	056387	1	103	
Pcb A.-Control*C602* Uvc4	X69068-SER	1	212	S/N M1037066 and Up - W/uvc4 U/d 216
Control-ROHS-Interface *C602*	063921-SER	1	212	STD and ROHS machine Replaces X55960-Ser and X63921-Ser
Pcb A.-Interface *C602* ROHS Dec Plate	X63921-SER	*	212	Use 063921-Ser Control-ROHS-Interface
+Chip-Software *C602* Fp	X40821-SER	*	103	
+Cable-Ribbon-14c-3"L-Sil/sil	056864	*	102	Standard and ROHS machine
+Insulator-Pcb-Interface *c60	057168	*	000	Standard and ROHS machine
Control-Interf-HT-SH-C602 ROHS	063965-SER	1	212	Replaces X59076-Ser and X63965-Ser
Control-ROHS-Person*C602*sh	063923-SER	1	212	

Description	Part Number	Qty.	Warranty Class	Remarks
Contr17o0l2-1r5o0hs-HT Intf Base-UK	063920-SER	1	212	
Pcb A.-Interface-HT-SH-C602	X59076-SER	*	212	Use 063965-Ser Control-INTERF-HT-SH-C602 Shake
Pcb A.-Personality C602 Shake	X59072-SER	*	212	Use 063923-Ser
Pcb A.-Heat Treat Intf Base-UK	X53451-SER	*	212	Use 063920-Ser
Pcb A.-Interface-HT-SH-C602	X63965-SER	*	212	Use 063965-Ser Control-INTERF-HT-SH ROHS - Shake
+Ctrl-ROHS-Personality *C602*sh	X63923-SER	*	212	Use 063965-Ser
+Ctrl-ROHS-HT Intf Base-UK	X63920-SER	*	212	Use 063920-Ser
Control-Interfce-HT-SS-UK ROHS	063964-SER	1	212	M2125873 and Up - ROHS Compatible Version Direct Sub X53453-Ser
Pcb A.-ROHS-Person-HT-SS	063922-SER	1	212	
Control-ROHS-HT Intf Base-UK	063920-SER	1	212	
Pcb A.-Interface-HT-SS-UK ROHS	X63964-SER	*	212	Use 063964-Ser
+Pcb A.-ROHS-Personality-HT-SS	X63922-SER	*	212	Use 063922-Ser
+Pcb A.-Interface Base-UK	X63920-SER	*	212	Use 063920-Ser
Pcb A.-CC-ROHS Pyro *C602*	069110-02S	1	212	
+Shield-Pyroelectric Sensor	064942	1	000	M1094977 and Up - Clear Cup Shake Holder Update 223
Pcb A.-Pyro CC-ROHS *C602*	X69110-02S	1	103	Use 069110-02s
Plug-Drain-Wyott	023953-5	3	103	Syrup Rail - Part Of Front Panel X55981
Probe A.-Mix Low-HT	X42077	2	103	
+Disc-Probe *sq Hole*	030965	2	103	
+Spacer-Probe *sq Hole*	030966	2	103	
Probe A.-Mix Out-Square Hole	X41348	2	103	
+Spacer-Probe-Square Hole-7/8	041346	2	103	
+Spacer-Probe-Round Hole-5/8DIA	041347	2	103	
+Spacer-Probe-Mix Low *8634*	043908	2	103	
Kit A.-Probe-Thermistor IP68	X82397-SER	5	103	S/N M4026480 and Up

Description	Part Number	Qty.	Warranty Class	Remarks
Probe-Thermistor-Hopper-2% T	039470-BLK	*	103	Use - X82397-Ser Kit A.-Probe-Thermistor IP68
Probe-Thermistor-Barrel-2% TOL	038061-BLK	*	103	Use - X82397-Ser Kit A.-Probe-Thermistor IP68
Pulley-AGT Dr-1.910PDX5/16 THD	036210	3	103	
Pulley-AW62-5/8	007538	1	103	
Pulley-2AK22 X .625-.6265	016403	1	103	
Pulley-AK25-5/8	019153	1	103	
Pulley-2AK74-5/8	027822	1	103	
+Guard-Pulley-Rear-Side *C602	056789	1	103	
Pump A.-Mix Simplified Shake	X57028-10	1	103	Shake
Adaptor-Mix Inlet *shake*blue*	054944	1	103	
Cap-Valve Body Shake	056873-10	1	103	
Cylinder-Pump Hopper Shake	057944	1	103	
Gasket-Simplified Pump Valve	086097	1	000	
O-ring-2-1/8 OD X .139w-#225	020051	2	000	
Pin A.-Retaining	X55450	1	103	
Piston-Pump-Simplified	053526	1	103	
+Clip-Retainer-Mix Pump	044641	1	103	
+Pin-Cotter-Hairpin-1/8dia	044731	1	103	
Pump A.-Mix Simplified S.s.	X57029-12	1	103	Soft Serve
Adaptor-Mix Inlet*soft/ser*red	054825	1	103	
Cap-Valve Body SS	056874-12	1	103	
Cylinder -Pump Hopper S.s.	057943	1	103	
Gasket-Simplified Pump Valve	086097	1	000	
O-ring-2-1/8 OD X .139w-#225	020051	2	000	
Pin A.-Retaining	X55450	1	103	

Description	Part Number	Qty.	Warranty Class	Remarks
Piston-Pump-Simplified	053526	1	103	
+Clip-Retainer-Mix Pump	044641	1	103	
+Pin-Cotter-Hairpin-1/8dia	044731	1	103	
Pump A.-Syrup-Heated-Tan	X53800-TAN	*	103	Shipped With machines Prior To S/N M107 U/d 221
Pump A.-Syrup-Heated-Brn	X53800-BRN	*	103	Shipped With machines Prior To S/N M107 U/d 221
Pump-Glycol-1/8npt-1650 Rpm	041785	1	212	
+Boot-Pump-Glycol	042131	1	000	
Pump-Peristaltic	052916	4	103	Pump A.-Ultimate Syrup
Clamp-Tube-Pump-Lower	052916-005	4	103	
Track-Pump Tube Upper	052916-009	4	103	
Clamp-Track-Pump	052916-010	4	103	
+Bushing-Split 43/64id X 7/8o	027691	4	000	
+Decal-Set Of 4 Colored Flavors	022105	1	000	
+Kit A.-Peristaltic Pump Tube	X54978	1	000	1 Tube
+Kit A.-Peristaltic Pump Tube	X54979	1	000	4 Tubes
+Moto1r70-G21e5ar 161 Rpm/short Shaft	058725	4	103	Pump A.-Ultimate Syrup
+Pan A.-Ultimate Syrup *C602*	X56006	1	103	
+Screw-10-32x3/8 SITD Truss	024298	2	000	
Sensor A.-Evc*C602*w/bracket	X84458	1	103	M5113432 and Up - Not 100% Interchangable With Previous X44951
+Screw-1/4-20x1/2 SITD Flat	078526	2	000	S/N M5113432 and Up
Sensor A.-Evc-Slush-6" *345-6*	X44951	1	103	K7025800 - M5113431
Sensor A.-Pyroelectric-6"L	X59268-SER	1	103	
+Shield-Pyroelectric Sensor	064942	1	000	
Shaft A.-Drive-Mix Pump-Hopper	X41947	2	103	Crank
Crank-Drive-Hopper Mix Pump	039235	1	103	

Description	Part Number	Qty.	Warranty Class	Remarks
O-ring-1-3/4 OD X .139w	008904	1	000	
Shaft-Drive-Mix Pump-Hopper	041948	1	103	
O-ring 1/2 ID X .139w	048632	2	000	
Shaft-Beater	032564	1	103	Soft Serve
+Seal-Drive Shaft	032560	1	000	
Shaft-Beater*7QT Fluted Blade	050985	1	103	Shake
+Seal-Drive Shaft	032560	1	000	
Shell A.-Insulated *C602*	X62257SSP1			S/N M5113432 and Up
Stud-Nose Cone *C602*	055987	8	000	
Shell A.-Insulated*C602*	X62257SER1	1	512	S/N M5113431 and Prior
Stud-Nose Cone *C602*	055987	8	000	
Shield-Pyroelectric Sensor	064942	1	000	M1094977 and Up - Clear Cup Shake Holder Update 223
Shield-Splash-Wire-19-3/4 L	033813	1	103	
Shroud-Front *C602*	055944	1	103	Standard machine
Shroud-Rear *C602*	055943	1	103	Standard machine
Shroud-Top *C602*	056504	1	103	Standard machine
Sleeve-Mounting-Comp.	039924	8	000	
Spring-Comp.970x.113x1.5	032967	4	103	
Solenoid-Draw Valve-SH *C602	081034	*	103	Use X81034-Ser Kit A.-Solenoid Draw Valve - S/N M2106288 and Up
+Screw-1/4-20x 7/8 SAE Grade	081033	*	000	
+Bumper-Recessed	057910	*	103	
Solenoid-Draw Valve-SH *C602	059462-CP	*	103	N/A Ref S/b S2612 Use X81034-Ser Kit A. Solenoid Draw
Kit A.-Solenoid Draw Valve	X81034-SER	1	103	Valve A.-Dispensing
+Bumper-Recessed	057910	1	103	
+Guide-Actuator *C602*	062199	1	103	

Description	Part Number	Qty.	Warranty Class	Remarks
+Screw-1/4-20x 7/8 SAE Grade	081033	2	000	
+Screw-1/4-20x1-1/4 Serr.flan	024351	1	000	
+Screw-1/4-20x3/4 Low Head	057911	1	000	
Starter-3 Phase 2.5 To 4 Amp	066794-33H	1	103	Shake
Overload-Thermal-3p-2.5/4.0a	067461-3H	1	103	
Starter-3 Phase 4 To 6.5 Amp	066794-33J	1	103	Soft Serve
Overload-Thermal-3p-4.0/6.5a	067461-3J	1	103	
Switch A.-Draw *C606*	X33322-SP1	1	103	K7095806 and Up
Arm A.-Draw *606*	X59431	1	103	
E-ring 3/16 .335 OD 1500-	049178	1	000	
Pin-Pivot	015478	1	103	
Screw-4-40x1 SITD Round	028890	2	000	
Spring-Return-Left-Self C	041660	1	103	
Spring-Return-Right-Self	041661	1	103	
Switch-Lever-Spdt-10a-125	028889	2	103	
Switch-Pressure 440 Psi-Solder	048230	2	103	
Switch-Reed*door Interlock*68"	056771	1	103	Soft Serve
+Spring-Interlock Door	065409	1	000	
+Fitting Door Interlock	065471	1	103	
Switch-Reed*door Interlock*97"	059071	1	103	Shake
+Spring-Interlock Door	065409	1	000	
+Fitting Door Interlock	065471	1	103	
Switch-Toggle-DPDT*VDE Approvd	054809	1	103	
+Guard-Power Switch	034830	1	103	
Tank-Glycol 1.5QT-Plastic	047314	1	103	

Description	Part Number	Qty.	Warranty Class	Remarks
Thermostat-Adj-Snap Acting	049993	2	103	Syrup Rail - Part Of Front Panel X55981
Thermostat-HI Limit-Snap Act	049992	2	103	Syrup Rail - Part Of Front Panel X55981
Thermostat-HI Limit Man Reset	068953-SP	1	103	M5064707 and Up Replaced 035786 Thermostat
Tool-MIX1P70U2M15P Shaft Removal	057167	1	000	
Tool-O-ring Removal-Freezer	048260-WHT	1	000	
Tool-Seal Install-Remove	035460	1	000	
Trans.-120/208/240V PRI 24VSEC	081783-27	*	103	Use X81783-27s Kit A.-Trans
Trans.-Cont.-40VA 208/240V	053072	*	103	Used S/N M5055866 and Prior With Lon
Trans.-Cont.-32VA 120/200/24	054834	1	103	
Trans.-Cont.-80VA 230V/24V	059993	1	103	
Tray-Drip-SYR RL	063876	1	103	Replaced 084684 Shelf-Drip Tray
Tray-Drip-19-5/8 L X 4-7/8	033812	1	103	
Tray-Parts-SS Side *C602*	059087	1	000	
Tray-Parts-Shake Side *C602*	059088	1	000	
Tray-Parts-Pump-Simplified	056525	2	000	
Kit A.-Solenoid Draw Valve	X81034-SER	1	103	9/24/2012 - Replaces 059462-Cp
Valve A.-Draw *C602*	X55820	1	103	S.s.
Valve A.-Draw*602/606 Shake*	059000	1	103	Shake
Valve-Access-1/4MFL X 3/8ODSDR	053565	4	103	
Valve-Check-Duckbill	500598	4	000	
Valve-Exp-Auto-1/4S X1/4 FPT	046365	2	103	
+Boot-Valve-Expansion	050900	2	000	
Valve-Solenoid 3-W 1/4fpt 24	037954-27	2	103	Glycol Heater
Varistor-280VAC RMS 17 Mm DIA S/N	030036	1	103	
4 Tank System				

Description	Part Number	Qty.	Warranty Class	Remarks
Fitting A.-Syrup Jug 36"	X53353-BLU	1	103	
Fitting A.-Syrup Jug 36"	X53353-BRN	1	103	
Fitting A.-Syrup Jug 36"	X53353-RED	1	103	
Fitting A.-Syrup Jug 36"	X53353-WHT	1	103	
Line A.-Syrup Door *C602*	X59304	1	103	
Tank-Syrup 4QT. Psd	056673	4	103	
+Cover-Syrup Tank	055432	4	103	
+Decal-Set Of 4 Syrup Flavor	021523	1	000	
4 Bag System				
Line A.-Syrup *C602*	X58450	4	103	
Tray A.-Syrup *C602*	X59143	1	103	
Water-Cooled				
Accumulator-Copper 2"DIA	053377	2	103	
Blower-100 CFM	012796-27	1	103	
Clamp-Hose 3/4 ID Const T	067113	8	000	
Clamp-Hose 1.813-2.75" Di	074429	1	000	
Condenser-WC-Coax	047540	2	103	
Coupling-3/8 NPT Black Pipe	010878	2	103	
Guard-Blower	022505	1	103	
Hose-Rubber 1/2 ID X 7/8 OD	R50200	15'	000	
Hose-W/fittings 1/2 Mp	020834-48	2	103	
Outlet A.-Tee Water Valve	X25900	1	103	
Panel-Rear-Lower *C606* Wc	059533	1	103	
Pipe Tee 3/8-Water Valve-Blk	032953	1	103	
Switch-Pressure 350 Psi-S	048231	2	103	

Description	Part Number	Qty.	Warranty Class	Remarks
Valve-Water 3/8 Reg/head Press	046686	2	103	
50Hz / 60Hz Special Voltage				C602-29 200V 60Hz 3PH, C60235 220V-240V 50Hz 3PH,
200V 60Hz 3PH				C60237 200V 50Hz 3PH, C60258 380V-415V 50Hz 3N~ (4-WIRE)
Belt-Ax33	024396		000	200V 60Hz 3ph
Block-Terminal 4p L1,I2,I	039424	*	103	Used S/N M5055867 and Prior With Lon
Cap-Valve Body Shake	056873-12	1	103	200V 60Hz 3ph
Cap-Valve Body Shake	056873-14	1	103	200V 60Hz 3ph
Cap-Valve Body Shake	056873-16	1	103	200V 60Hz 3ph
Cap-Valve Body SS	056874-12	1	103	200V 60Hz 3ph
Cap-Valve Body SS	056874-14	1	103	200V 60Hz 3ph
Cap-Valve Body SS	056874-16	1	103	200V 60Hz 3ph
Cord-6-4 So	064860-116	1	103	200V 60Hz 3ph
Diagram-Wiring *C602*	059480-39	1	000	200V 60Hz 3ph
Fuse-12 Amp-Buss Bk/abc-12-R	064536	1	000	200V 60Hz 3ph
+Holder-Fuse-Inline-Type Hfa-	064538	1	103	200V 60Hz 3ph
Harness1-W70i2r1e5 -Mix Pump AGI	056430-58	1	103	200V 60Hz 3ph
Harness-Wire-Syrup	056431	1	103	200V 60Hz 3ph
Motor-1.0 HP	013102-33	1	212	200V 60Hz 3ph
Motor-1.5 HP	021522-33	1	212	200V 60Hz 3ph
Motor-Reducer-Service	044723-27S	1	212	200V 60Hz 3ph
Pulley-AGT Dr-1.910pdx5/16 Thd	036210	3	103	200V 60Hz 3ph
Pulley-AW62-5/8	007538	1	103	200V 60Hz 3ph
Pulley-2ak22 X .625-.6265	016403	1	103	200V 60Hz 3ph
Pulley-AK25-5/8	019153	1	103	200V 60Hz 3ph
Pulley-2ak74-5/8	027822	1	103	200V 60Hz 3ph

Description	Part Number	Qty.	Warranty Class	Remarks
Shell A.-Insulated *C602*	X62257SSP2	1	512	200V 60Hz 3ph S/N M5113431 and Prior
Shell A.-Insulated *C602*	X62257SSP	1	512	200V 60Hz 3ph S/N M5113432 and Up
Spring-Comp.970x.113x1.5	032967	4	103	200V 50Hz 3ph
220V-240V 50Hz 3PH				
Belt-Ax34	025729	2	000	220V-240V 50Hz 3ph
Cap-Valve Body Shake	056873-12	1	103	220V-240V 50Hz 3ph
Cap-Valve Body Shake	056873-16	1	103	220V-240V 50Hz 3ph
Cap-Valve Body Shake	056873-14	1	103	220V-240V 50Hz 3ph
Cap-Valve Body SS	056874-14	1	103	220V-240V 50Hz 3ph
Cap-Valve Body SS	056874-12	1	103	220V-240V 50Hz 3ph
Cap-Valve Body SS	056874-16	1	103	220V-240V 50Hz 3ph
Control-Limit Manual Rese	X77951-SER	2	103	220V-240V 50Hz 3ph
Diagram-Wiring *C602*	059480-35	1	000	220V-240V 50Hz 3ph
Fuse-12 Amp-Buss Bk/abc-12-R	064536	1	000	220V-240V 50Hz 3ph
+Holder-Fuse-Inline-Type Hfa-	064538	1	103	220V-240V 50Hz 3ph
Harness-Wire-Mix Pump AGI	056430-58	1	103	220V-240V 50Hz 3ph
Harness-Wire-Syr-Heaters*	068342-40	2	103	220V-240V 50Hz 3ph
Motor-1.0 HP	013102-35	1	212	220V-240V 50Hz 3ph
Motor-1.5 HP	021522-35	1	212	220V-240V 50Hz 3ph
Motor-Reducer 108rpm-SHK-	044723-34S	1	212	220V-240V 50Hz 3ph
Pulley-2ak27 X .625-.6265	011545	1	103	220V-240V 50Hz 3ph
Pulley-AGT Dr-1.690pdx5/1	045717	1	103	220V-240V 50Hz 3ph
Pulley-AGT Dr-1.910pdx5/1	036210	2	103	220V-240V 50Hz 3ph
Pulley-AGT Mtr-2.110pdx3/	045718	1	103	220V-240V 50Hz 3ph
Pulley-AK30 X 5/8	033559	1	103	220V-240V 50Hz 3ph

Description	Part Number	Qty.	Warranty Class	Remarks
Shell A.-Insulated *C602*	X62257SSP1	1	512	220V-240V 50Hz 3ph S/N M5113432 and Up
Shell A.-Insulated *C602*	X62257SER1	1	512	220V-240V 50Hz 3ph S/N M5113431 and Prior
Spring-Comp.970x.113x1.5	032967	2	103	220V-240V 50Hz 3ph
Spring-Comp.970x.115x2.00	025707	2	103	220V-240V 50Hz 3ph
200V 50Hz 3PH				
Belt-Ax34	025729	2	000	200V 50Hz 3ph
Cap-Valve Body Shake	056873-12	1	103	200V 50Hz 3ph
Cap-Valve Body Shake	056873-16	1	103	200V 50Hz 3ph
Cap-Valve Body Shake	056873-14	1	103	200V 50Hz 3ph
Cap-Valve Body SS	056874-14	1	103	200V 50Hz 3ph
Cap-Valve Body SS	056874-12	1	103	200V 50Hz 3ph
Cap-Valve Body SS	056874-16	1	103	200V 50Hz 3ph
Control-Limit Manual Rese	X77951-SER	2	103	200V 50Hz 3ph
Cord-6-4 So	064860-116	1	103	200V 50Hz 3ph
Diagram-Wiring *C602*	059480-39	1	000	200V 50Hz 3ph
Fuse-12 Amp-Buss Bk/abc-12-R	064536	1	000	200V 50Hz 3ph
+Holder-Fuse-Inline-Type HFA-	064538	1	103	200V 50Hz 3ph
Harness-Wire-Mix Pump AGI	056430-58	1	103	200V 50Hz 3ph
Harness-Wire-Syr-Heaters*	068342-40	2	103	200V 50Hz 3ph
Motor-1.0 HP	013102-33	1	212	200V 50Hz 3ph
Motor-1.5 HP	021522-33	1	212	200V 50Hz 3ph
Motor-Reducer 108RPM-SHK-	044723-34S	1	212	200V 50Hz 3ph
Pulley-2AK27 X .625-.6265	011545	1	103	200V 50Hz 3ph
Pulley-AGT Dr-1.690PDX5/1	045717	1	103	200V 50Hz 3ph
Pulley-A1g7t02d15r-1.910pdx5/1	036210	2	103	200V 50Hz 3ph

Description	Part Number	Qty.	Warranty Class	Remarks
Pulley-AGT Mtr-2.110pdx3/	045718	1	103	200V 50Hz 3ph
Pulley-AK30 X 5/8	033559	1	103	200V 50Hz 3ph
Shell A.-Insulated *C602*	X62257SSP2	1	512	200V 50Hz 3ph S/N M5113432 and Up
Shell A.-Insulated *C602*	X62257SSP	1	512	200V 50Hz 3ph S/N M5113431 and Prior
Spring-Comp.970x.113x1.5	032967	2	103	200V 50Hz 3ph
Spring-Comp.970x.115x2.00	025707	2	103	200V 50Hz 3ph
380V-415V 50HZ 3N~ (4-Wire)				
Belt-Ax34	025729	2	000	380V-415V 50Hz 3N~ (4-WIRE)
Block-Terminal 4p L1,I2,I	039424	2	103	380V-415V 50Hz 3N~ (4-WIRE)
Cap-Valve Body Shake	056873-16	1	103	380V-415V 50Hz 3N~ (4-WIRE)
Cap-Valve Body Shake	056873-14	1	103	380V-415V 50Hz 3N~ (4-WIRE)
Cap-Valve Body Shake	056873-12	1	103	380V-415V 50Hz 3N~ (4-WIRE)
Cap-Valve Body SS	056874-14	1	103	380V-415V 50Hz 3N~ (4-WIRE)
Cap-Valve Body SS	056874-12	1	103	380V-415V 50Hz 3N~ (4-WIRE)
Cap-Valve Body SS	056874-16	1	103	380V-415V 50Hz 3N~ (4-WIRE)
Compressor L63A113DBEA-40	048259-58H	1	512	380V-415V 50Hz 3N~ (4-WIRE)
Compressor M63B203DBEB-40	062274-58H	1	512	380V-415V 50Hz 3N~ (4-WIRE)
Control-ROHS-Interface *C602*	066921-SER	1	212	380V-415V 50Hz 3N~ (4-WIRE)
Diagram-Wiring *C602*	059480-58	1	000	380V-415V 50Hz 3N~ (4-WIRE)
Diagram-Wiring *C602/C606	05948058SP	1	000	380V-415V 50Hz 3N~ (4-WIRE) C60258FWJE
Fuse-Buss-Abc-15-R ROHS Comp	076414	2	000	380V-415V 50Hz 3N~ (4-WIRE)
Fuse-12 Amp-Buss Bk/abc-12-R	064536	1	000	380V-415V 50Hz 3N~ (4-WIRE)
+Holder-Fuse-Inline-Type HFA-	064538	3	103	380V-415V 50Hz 3N~ (4-WIRE)
Harness-Wire-Mix Pump AGI	056430-58	1	103	380V-415V 50Hz 3N~ (4-WIRE)
Motor-1.0 HP	013102-35	1	212	380V-415V 50Hz 3N~ (4-WIRE)

Description	Part Number	Qty.	Warranty Class	Remarks
Motor-1.5 HP	021522-35	1	212	380V-415V 50Hz 3N~ (4-WIRE)
Motor-Reducer 108RPM-SHK-	044723-34S	1	212	380V-415V 50Hz 3N~ (4-WIRE)
Pulley-2AK27 X .625-.6265	011545	1	103	380V-415V 50Hz 3N~ (4-WIRE)
Pulley-AGT Dr-1.690PDX5/1	045717	1	103	380V-415V 50Hz 3N~ (4-WIRE)
Pulley-AGT Dr-1.910PDX5/1	036210	2	103	380V-415V 50Hz 3N~ (4-WIRE)
Pulley-AGT Mtr-2.110PDX3/	045718	1	103	380V-415V 50Hz 3N~ (4-WIRE)
Pulley-AK30 X 5/8	033559	1	103	380V-415V 50Hz 3N~ (4-WIRE)
Shell A.-Insulated *C602*	X62257SSP1	1	512	380V-415V 50Hz 3N~ (4-WIRE) S/N M5113432 and Up
Shell A.-Insulated *C602*	X62257SER1	1	512	380V-415V 50Hz 3N~ (4-WIRE) S/N M5113431 and Prior
Spring-Comp.970x.113x1.5	032967	2	103	380V-415V 50Hz 3N~ (4-WIRE)
Spring-Comp.970x.115x2.00	025707	2	103	380V-415V 50Hz 3N~ (4-WIRE)
Starter-3 Phase 2.5 To 4	066794-33H	1	103	380V-415V 50Hz 3N~ (4-WIRE)
Starter-3 Phase 1.6 To 2	066794-33G	1	103	380V-415V 50Hz 3N~ (4-WIRE)

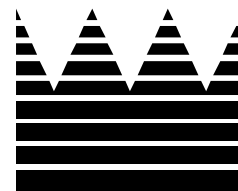

Section 6: Wiring Diagrams

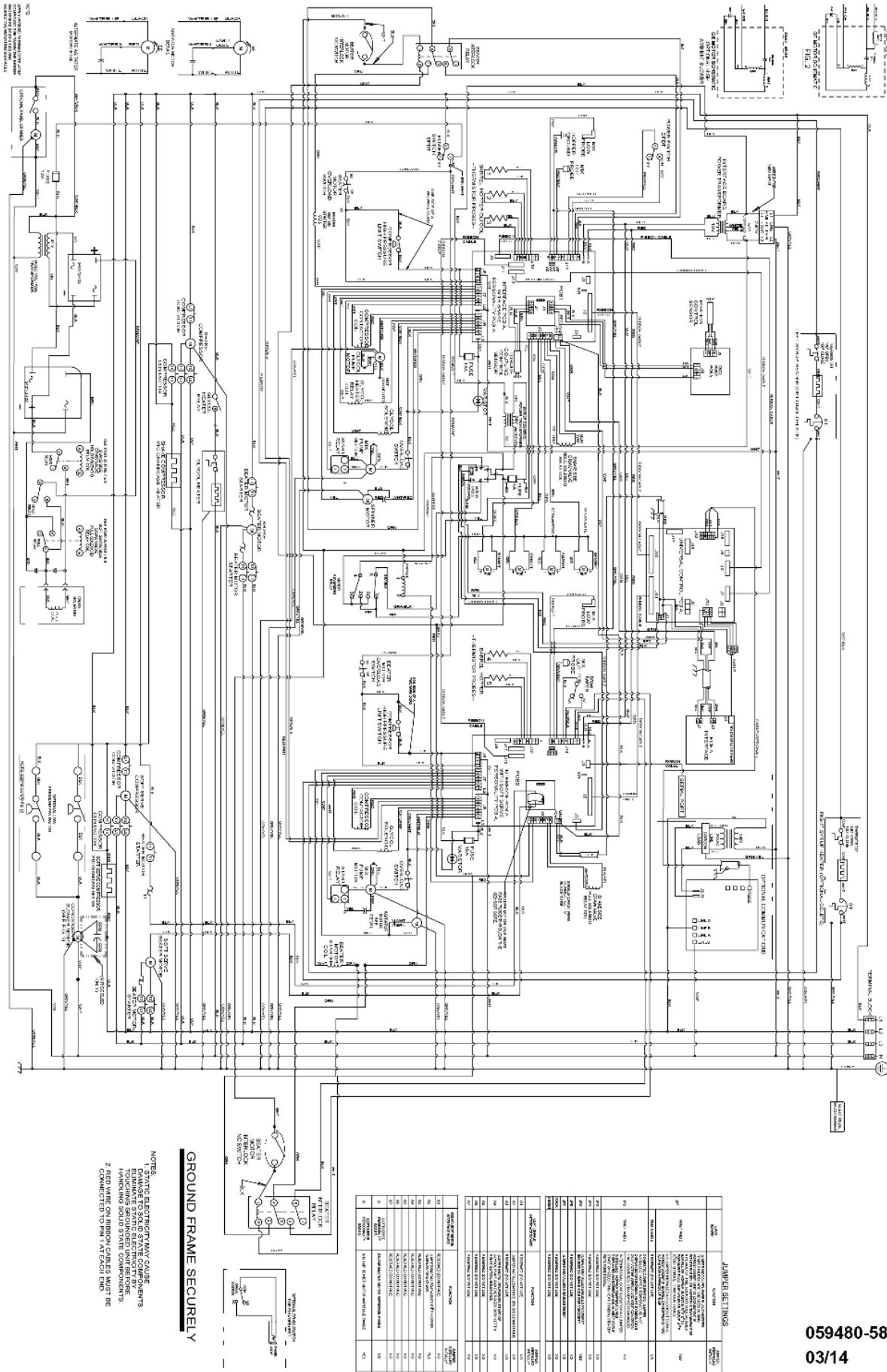

Figure 6-1

059480-58
03/14